

THIS DRAWING IS UNPUBLISHED. RELEASED FOR PUBLICATION
 © COPYRIGHT BY TYCO ELECTRONICS CORPORATION. ALL RIGHTS RESERVED.

LOC	DIST	REVISIONS			
P	LTR	DESCRIPTION	DATE	DWN	APVD
CM	00	R1	REV PER ECN 0G3B-0721-03	10SEP03	KW JE

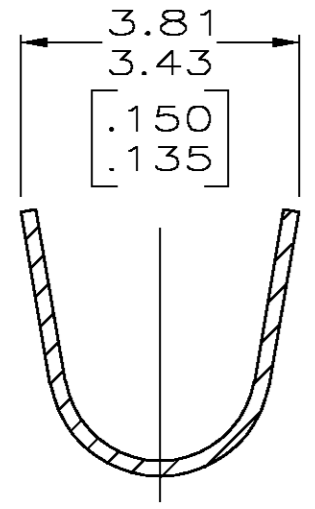

SECTION C-C

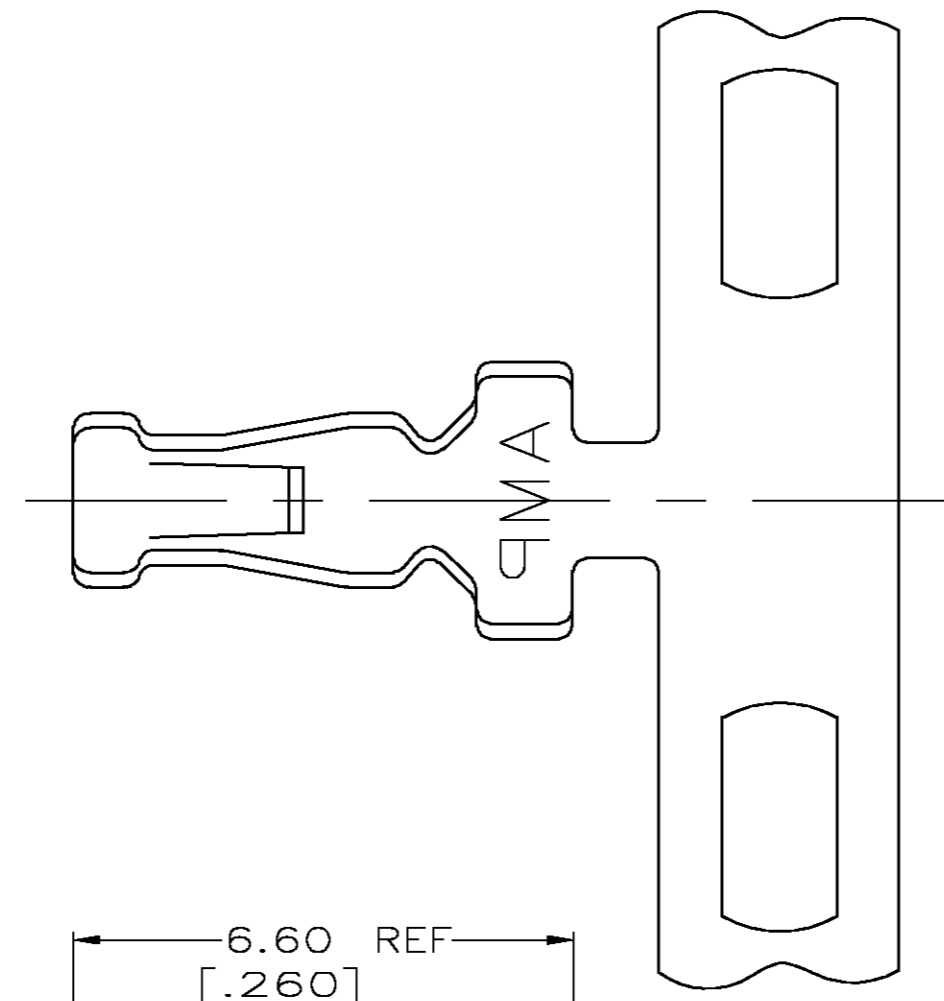
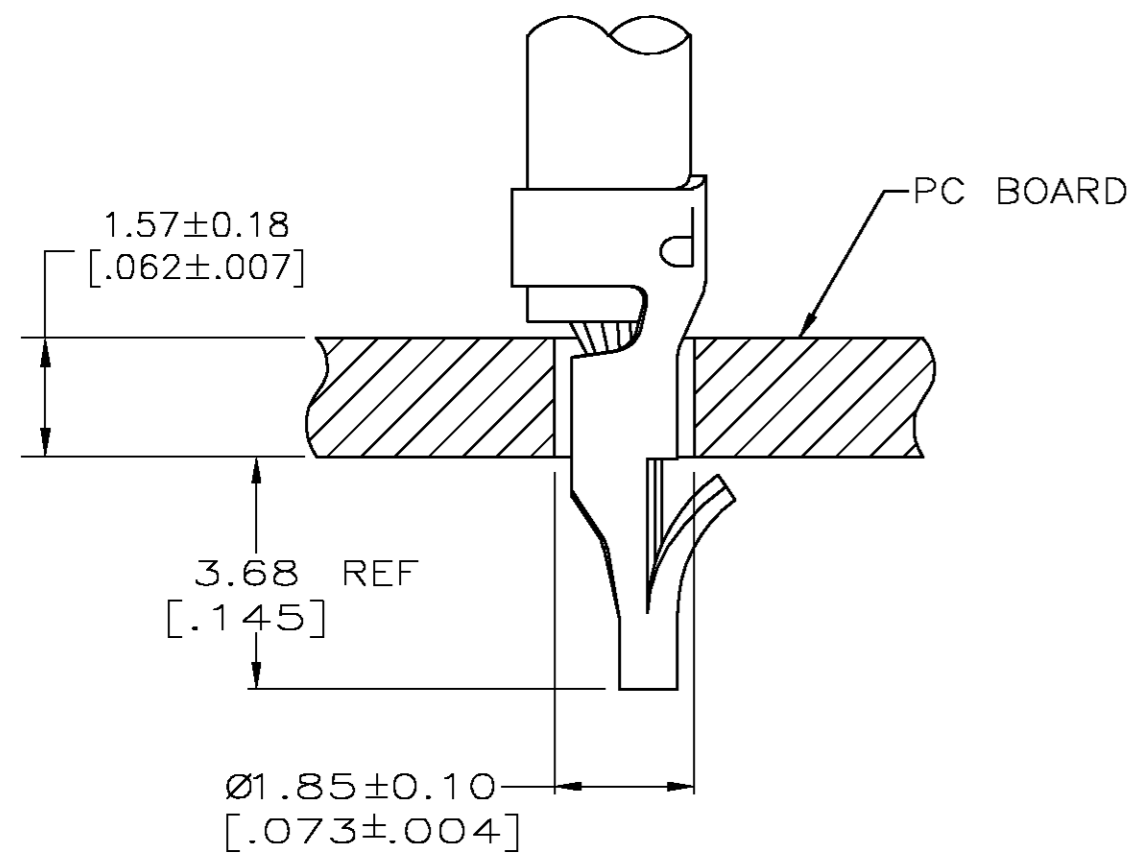
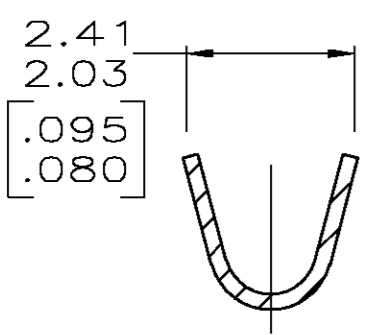
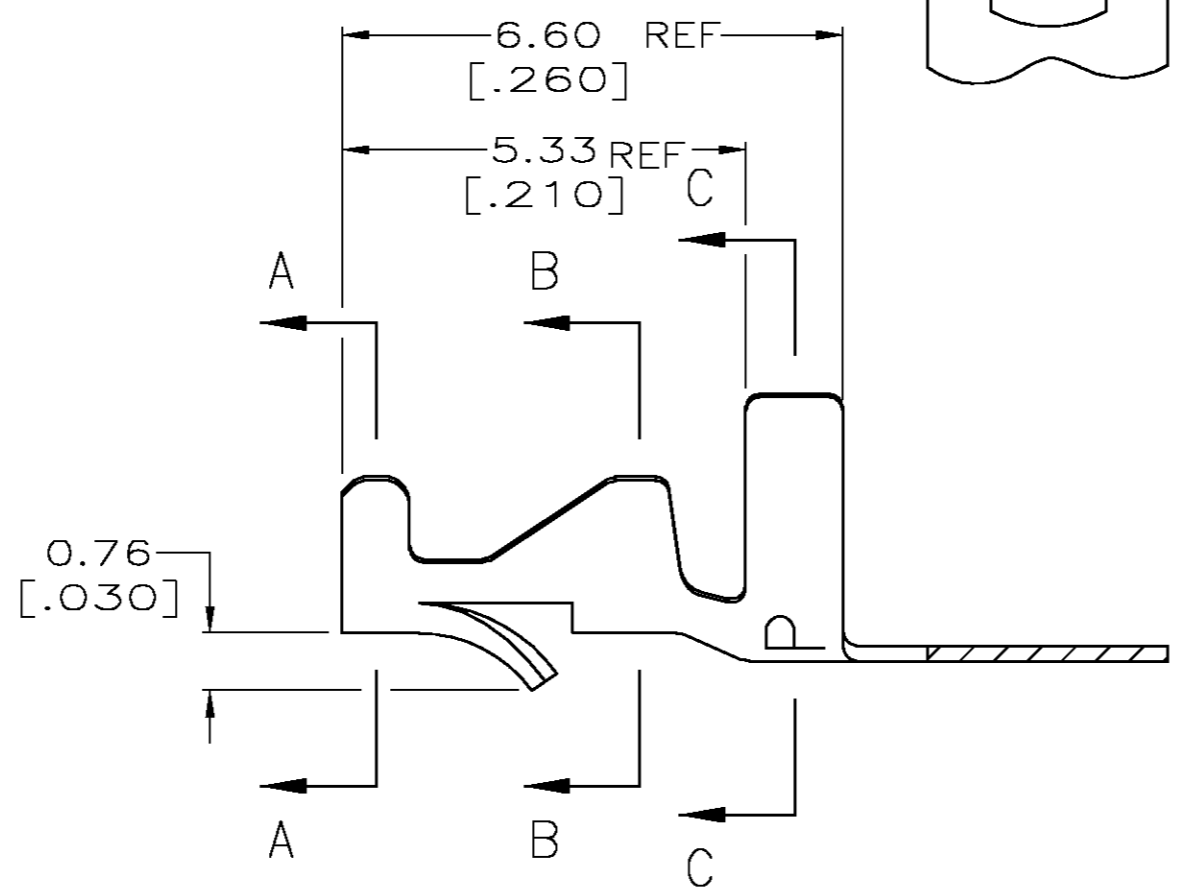

SECTION A-A, B-B

- ① PARTS COMPLY WITH AMP SOLDERABILITY SPEC 109-11-3.
- ② 0.00508 [.000200] MIN BRIGHT TIN-LEAD.
- ③ PARTS COMPLY WITH AMP SOLDERABILITY SPEC 109-11-1.
- ④ 0.00305 [.000120] MIN BRIGHT TIN-LEAD OVER 0.00102 [.000040] MIN NICKEL.
- ⑤ FOR FOREIGN PRODUCTION ONLY.
- ⑥ CARRIER STRIP TO HAVE 1.52 [.060] DIA PILOT HOLE.
- ⑦ 0.00305 [.000120] MIN TIN OVER 0.00102 [.000040] MIN NICKEL.
- ⑧ WIRE RANGE: 0.3 - 0.9 mm² (22 - 18 AWG).
- ⑨ INSULATION RANGE: 1.52 - 2.79 [.060 - .110] DIA.
- ⑩ DIMENSIONS IN BRACKETS ARE IN INCHES.
- ⑪ 0.00508 [.000200] MIN BRIGHT TIN.

NOTES	FINISH	MATERIAL	PART NO.
①	⑪	0.20[.008] PH BRZ	3-640311-1
③⑤⑥	⑦	0.20[.008] BRASS	640311-5
③⑤	④	0.20[.008] BRASS	640311-3
①	②	0.20[.008] PH BRZ	640311-1

THIS DRAWING IS A CONTROLLED DOCUMENT.		DWN S. CARPENTER 21AUG2003	Tyco Electronics Corporation Harrisburg, PA 17105	
DIMENSIONS: INCHES		CHK J. ELLIS 21AUG2003	NAME MINI AMP-IN™	
TOLERANCES UNLESS OTHERWISE SPECIFIED: 0 PLC ± 1 PLC ± 2 PLC ± 0.13 [.005] 3 PLC ± 4 PLC ± ANGLES ±		APVD J. ELLIS 21AUG2003	APPLICATION SPEC 114-1016	
MATERIAL SEE TABLE		FINISH SEE TABLE	SIZE A2	CAGE CODE 00779
METRIC		DRAWING NO C=640311		RESTRICTED TO -
CUSTOMER DRAWING			SCALE 10:1	SHEET 1 OF 1
			REV R1	



A/C BUSINESS GROUP 3323 177-34 RALPH VESTAL

640311