

THIS DRAWING IS UNPUBLISHED. RELEASED FOR PUBLICATION
 © COPYRIGHT BY TYCO ELECTRONICS CORPORATION. ALL RIGHTS RESERVED.

LOC	DIST	REVISIONS					
AG	0	P	LTR	DESCRIPTION	DATE	DWN	APVD
		G		ADDED: -3 PER EC 0S11-0090-03	11AUG2003	DD	KK

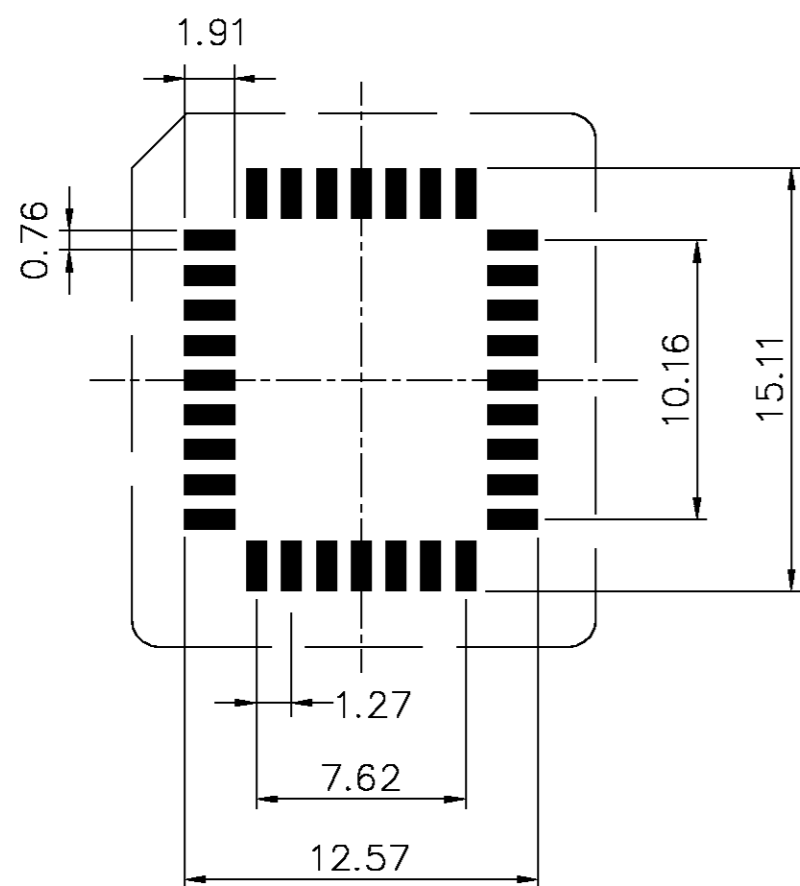
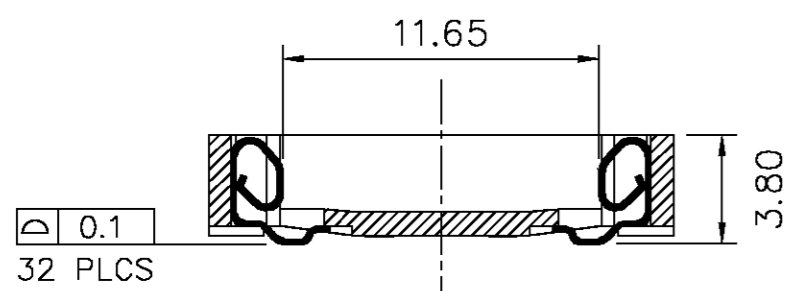
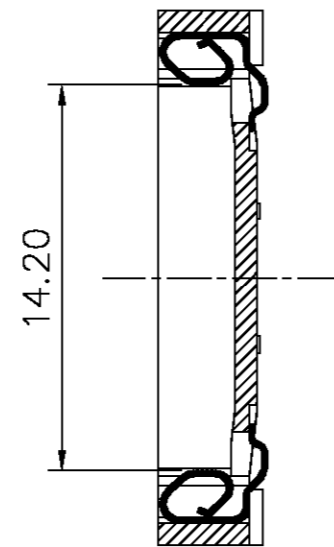
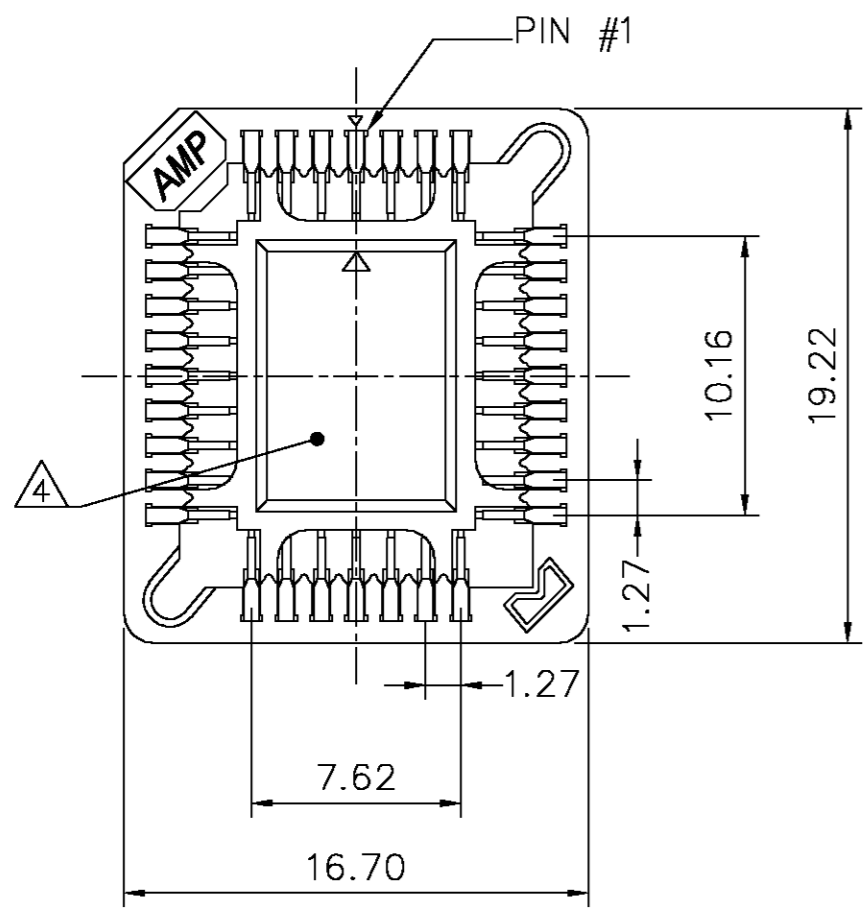

P.C.B. LAYOUT

- 1 MATERIALS:
HOUSING - HIGH TEMPERATURE THERMOPLASTIC, UL94V-0, COLOR: BROWN.
CONTACT - PHOSPHOR BRONZE.
- 2 FINISH, CONTACT: 0.0038 MIN 100% TIN OVER 0.0011 MIN NICKEL.
- 3 PLCC DEVICE SHALL CONFORM TO JEDEC STANDARD MS-016.
- 4 HOUSING FLOOR TO BE SMOOTH WITHIN A 5.20 DIAMETER FOR VACUUM PLACEMENT.
- 5 TAPE PACKAGING TO CONFORM TO EIA RS-481-3. TAPE WIDTH SHALL BE 32mm, TAPE PITCH SHALL BE 24mm, AND REEL DIAMETER SHALL BE 330mm.
- 6 PLCC EXTRACTION TOOL: AMP PART NUMBER 821980-1 OR 822476-1.
- 7 PRODUCT DESIGN OBJECTIVES:
CURRENT RATING: 1 AMP, MAXIMUM
CONTACT RESISTANCE: 20 MILLIOHMS, MAXIMUM
DIELECTRIC WITHSTAND VOLTAGE: 600VAC, RMS, MINIMUM
INSULATION RESISTANCE: 5,000 MEGOHMS, MINIMUM
DURABILITY: 25 CYCLES
OPERATING TEMPERATURE RANGE: -55 TO +105C
MATING FORCE: 9.0 Kg, MAXIMUM
- 8 FINISH, CONTACT: 0.0038 MIN 93/7 TIN-LEAD OVER 0.0011 MIN NICKEL.
- 9 TUBE LENGTH 535mm. EXTERNAL CARTON 580 x 240 x 260mm TO HOLD 8,008 PIECES.

2	9	308	26	TUBES	822475-3
2	5	5	500	TAPE AND REEL	822475-2
8	5	5	500	TAPE AND REEL	822475-1
FINISH	TUBES OR REELS/BOX	PCS/REEL OR TUBE	PACKAGING STYLE	AMP PART NUMBER	

THIS DRAWING IS A CONTROLLED DOCUMENT.		DWN A. HOLT 19OCT99	Tyco Electronics Corporation Harrisburg, PA 17105-3608	
DIMENSIONS: MM		CHK K. KREIDLER 18OCT99	APVD K. KREIDLER 18OCT99	
TOLERANCES UNLESS OTHERWISE SPECIFIED:		NAME K. KREIDLER		
0 PLC ± -		PRODUCT SPEC		
1 PLC ± -		APPLICATION SPEC		
2 PLC ± 0.20		NONE		
3 PLC ± -		WEIGHT 0.9 GRAMS		
4 PLC ± -		SIZE A2		
ANGLES ± -		CAGE CODE 00779		
FINISH SEE TABLE		DRAWING NO C=822475		
		RESTRICTED TO -		
		SCALE 3:1 SHEET 1 OF 1 REV G		