

THIS DRAWING IS UNPUBLISHED. RELEASED FOR PUBLICATION, 19  
 © COPYRIGHT 19 BY AMP INCORPORATED. ALL INTERNATIONAL RIGHTS RESERVED.

LOC	DIST	P	F	REVISIONS				
G	14			ZONE	LTR	DESCRIPTION	DATE	APPD
					M1	REV PER ECR 06-001832	24APR06	JR/TM

<b>AMP</b> WIRE RANGE	Listed	LR7189 Certified
16-14 AWG SOLID OR STRANDED	16-14 AWG SOLID OR STRANDED	16-14 AWG SOLID OR STRANDED

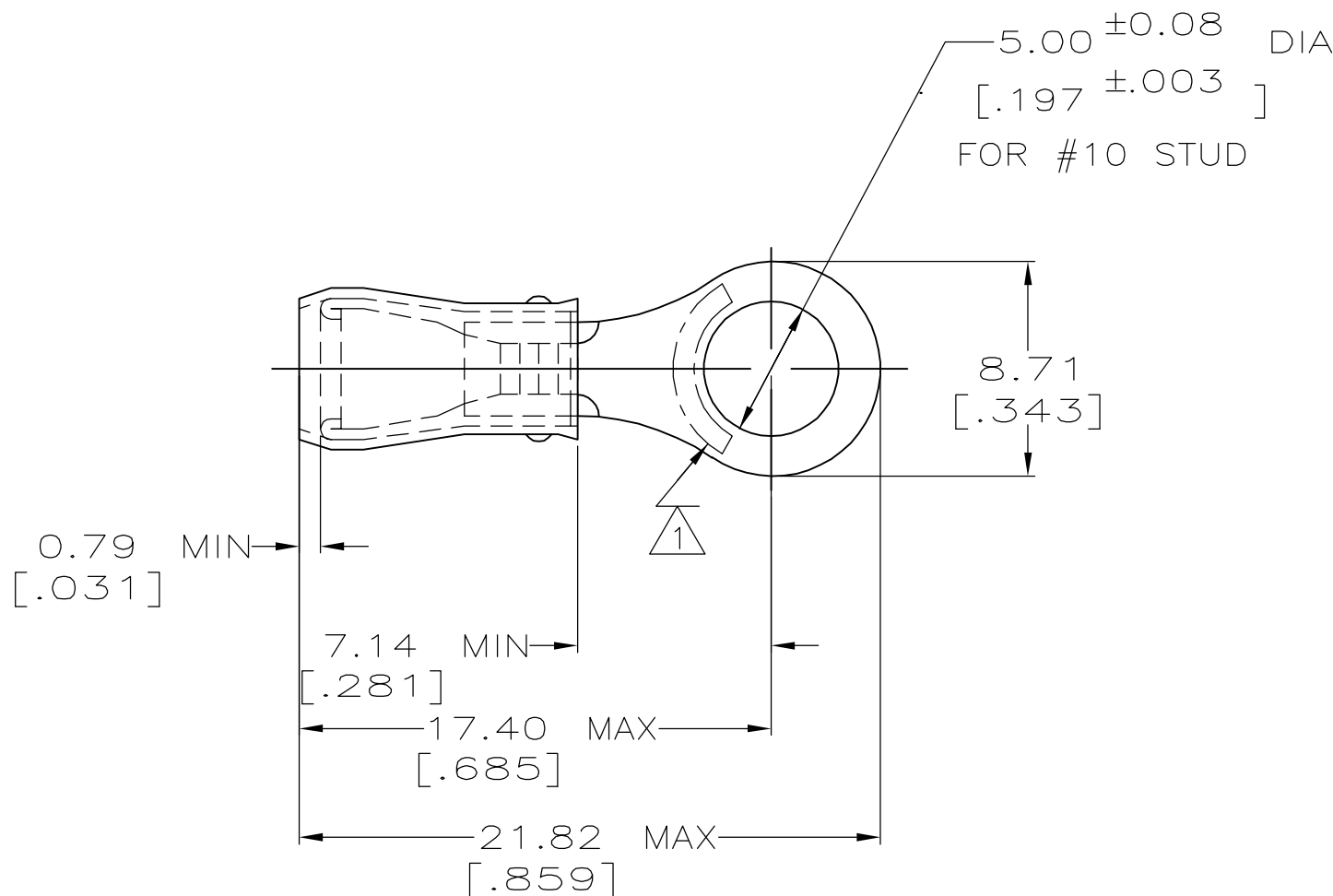

- 1 STAMP AMP 16-14\* APPROX AS SHOWN  
STAMP MAY BE ON TOP OR BOTTOM.
- 2 WIRE INSUL DIA, 2.92-4.32 [.115-.170]
- 3 TONGUE MATERIAL THK, 0.79±0.05 [.031±.002]
- 4 SUPERSEDED BY 8-36160-5

4	25	LOOSE PIECE, BLS	9-36160-4
	50	LOOSE PIECE, BAG	8-36160-5
4	5	LOOSE PIECE, BLS	8-36160-4
	100	LOOSE PIECE, BOX	8-36160-1
	5000	ON TAPE, REEL	2-36160-1
	1000	LOOSE PIECE	36160

<b>AMP INCORPORATED</b> CUSTOMER SERVICE SYSTEMS		MAX RECOMMENDED OPERATING TEMPERATURE: 105° C [221° F]	DO NOT SCALE PRINT. UNLESS SPECIFIED DIMENSIONS IN mm [INCHES] TOLERANCES ON: 2 PLC DEC ± 0.20[.008] 3 PLC DEC ± - ANGLES ± -	DR 17DEC99 JR RUTH CHK 17DEC99 RE HERSEY APPD 17DEC99 T MICHIELUTTI APPD 17DEC99 T MICHIELUTTI PRODUCT SPEC UL 486A APPLICATION SPEC 114-2157 WEIGHT -	QUANTITY	PACKAGE TYPE	PART NO
FOR ADDITIONAL PRODUCT INFORMATION OR COPIES OF DRAWINGS AND TECHNICAL DOCUMENTS	PRODUCT INFORMATION CENTER 1-800-522-6752	VOLTAGE RATING: 300 V MAX	MATERIAL COPPER ASTM B-152 SLEEVE BLUE NYLON	<b>AMP</b> AMP Incorporated Harrisburg, PA 17105-3608			
FOR APPLICATION TOOLING INFORMATION	TOOLING ASSISTANCE CENTER 1-800-722-1111	WIRE CROSS SECTIONAL AREA RANGE: 1.04-2.62mm <sup>2</sup> [2,050-5,180] CIR MILS	FINISH TIN PLATE ASTM B545	NAME TERMINAL, RING TONGUE, PIDG™, WIRE SIZE: 16-14 AWG			
FOR ORDER ENTRY	1-800-526-5142	THIS DRAWING IS A CONTROLLED DOCUMENT FOR AMP INCORPORATED. IT IS SUBJECT TO CHANGE AND THE CONTROLLING ENGINEERING ORGANIZATION SHOULD BE CONTACTED FOR THE LATEST REVISION.		SIZE <b>B</b>	CAGE CODE 00779	DRAWING NO <b>C-36160</b>	
				SCALE 4:1	SHEET 1 OF 1		