

REVISIONS					
P	LR	DESCRIPTION	DATE	DNK	APPD
H6		REVISED PER ECO-15-010566	23JUL2015	NK	MM
H7		REVISED PER ECO-19-015225	16OCT2019	RS	JO

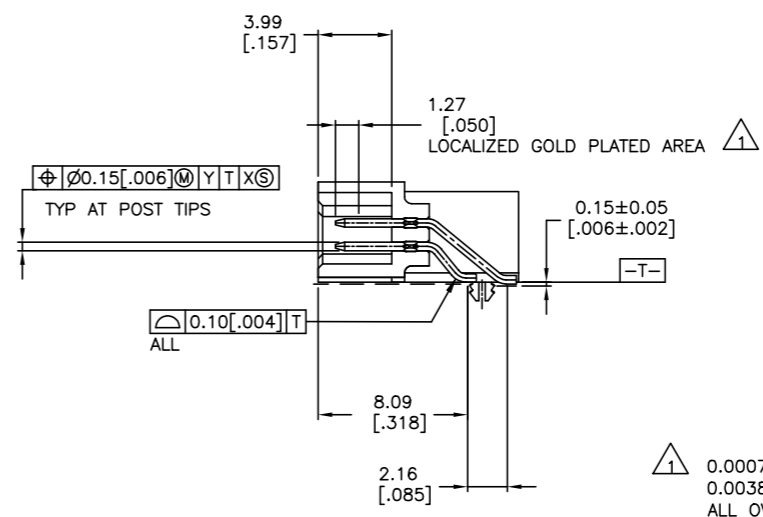

- 1 0.00076[.000030] GOLD IN LOCALIZED PLATE AREA 0.00381[.000150] TIN-LEAD ON SOLDER TAILS ALL OVER 0.00127[.000050] NICKEL
- 2 USE 1.32±0.02[.0520±.0010] DRILLED HOLE(#55 DRILL) FINISH TO BE TIN/LEAD OVER 0.02[.001] MIN COPPER
- 3 PLATING: 0.0038 [.000150] TIN-LEAD OVER 0.00127[.000050] NICKEL
- 4 SERRATIONS OPTIONAL THIS SURFACE.
- 5 0.00076(.000030) GOLD IN LOCALIZED PLATE AREA 0.00381(.000150) TIN ON SOLDER TAILS ALL OVER .00127(.000050) NICKEL.
- 6 USE 1.32+/-0.02(.052+/-0.0010) DRILLED HOLE (#55 DRILL) WITH 0.02(.0010) MIN COPPER." ADD NOTE 7 TO READ AS FOLLOWS:"PLATING: 0.00381(.000150) TIN OVER 0.00127(.000050) NICKEL.
- 7 PLATING: 0.0038[.000150] TIN OVER 0.00127[.000050] NICKEL
- 8 OBSOLETE PARTS: OBSOLETE CIS STREAMLINING PER D.RENAUD/D.SINISI

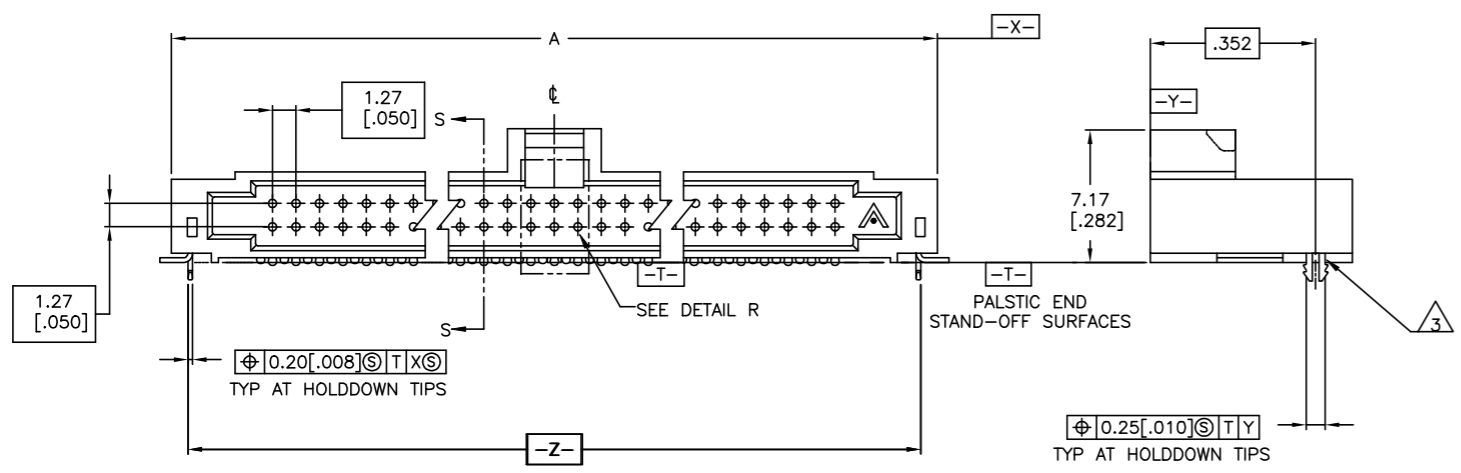
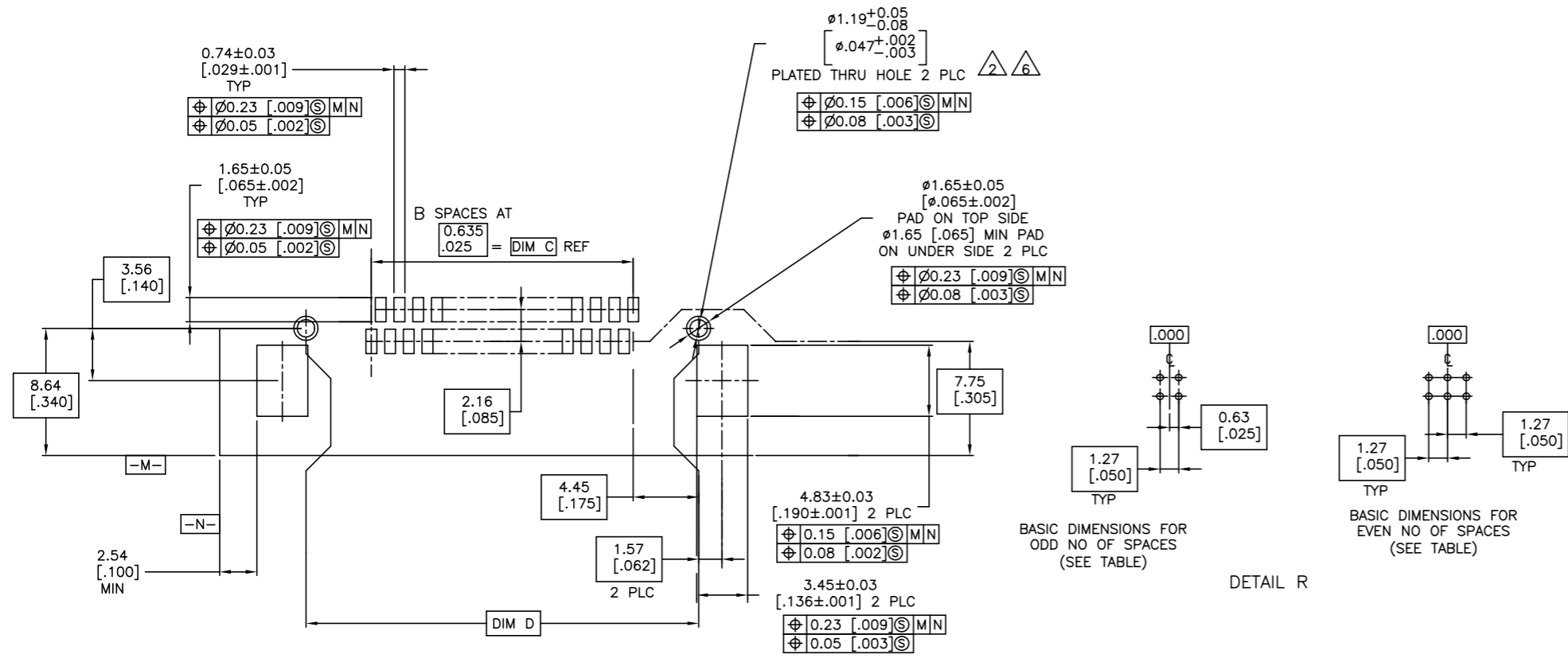
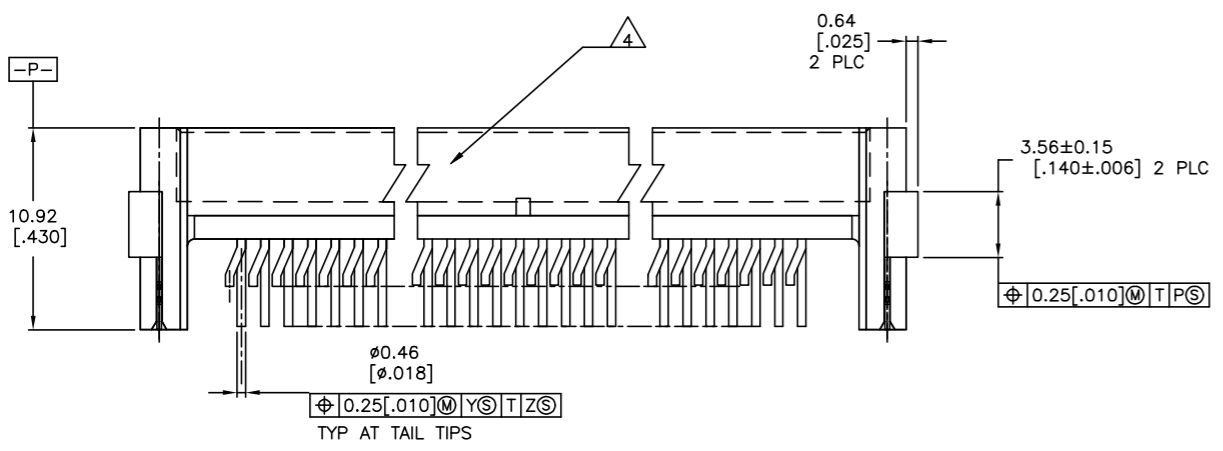

BASIC DIMENSIONS FOR ODD NO OF SPACES (SEE TABLE)

BASIC DIMENSIONS FOR EVEN NO OF SPACES (SEE TABLE)

FINISH	NO. OF SPA (SEE DETAIL R)	D	C	B	A	NUMBER OF POSITIONS	PART NUMBER
5 7	49	71.12 [2.800]	62.87 [2.475]	99	73.15 [2.880]	100	6-104895-0
5 7	44	64.77 [2.550]	56.52 [2.225]	89	66.80 [2.630]	90	5-104895-9
5 7	39	58.42 [2.300]	50.17 [1.975]	79	60.45 [2.380]	80	5-104895-8
5 7	34	52.07 [2.050]	43.82 [1.725]	69	54.10 [2.130]	70	5-104895-7
5 7	29	45.72 [1.800]	37.47 [1.475]	59	47.75 [1.880]	60	5-104895-6
5 7	24	39.37 [1.550]	31.12 [1.225]	49	41.40 [1.630]	50	5-104895-5
1 3	19	33.02 [1.300]	24.77 [.975]	39	35.05 [1.380]	40	5-104895-4
5 7	14	26.67 [1.050]	18.42 [.725]	29	28.70 [1.130]	30	5-104895-3
5 7	9	20.32 [.800]	12.07 [.475]	19	22.35 [.880]	20	5-104895-2
5 3	4	13.97 [.550]	5.72 [.225]	9	16.00 [.630]	10	5-104895-1
8	49	71.12 [2.800]	62.87 [2.475]	99	73.15 [2.880]	100	1-104895-0
8	44	64.77 [2.550]	56.52 [2.225]	89	66.80 [2.630]	90	104895-9
8	39	58.42 [2.300]	50.17 [1.975]	79	60.45 [2.380]	80	104895-8
8	34	52.07 [2.050]	43.82 [1.725]	69	54.10 [2.130]	70	104895-7
8	29	45.72 [1.800]	37.47 [1.475]	59	47.75 [1.880]	60	104895-6
8	24	39.37 [1.550]	31.12 [1.225]	49	41.40 [1.630]	50	104895-5
8	19	33.02 [1.300]	24.77 [.975]	39	35.05 [1.380]	40	104895-4
8	14	26.67 [1.050]	18.42 [.725]	29	28.70 [1.130]	30	104895-3
8	9	20.32 [.800]	12.07 [.475]	19	22.35 [.880]	20	104895-2
8	4	13.97 [.550]	5.72 [.225]	9	16.00 [.630]	10	104895-1

RECOMMENDED BOARD LAYOUT
SCALE 5:1

THIS DRAWING IS A CONTROLLED DOCUMENT. DWG: J.HERRINGTON 23-6-93, APPD: P.SREMCICH 24-6-93, CHK: D.DUPLER 24-6-93

TE Connectivity

ASSEMBLY, HEADER, RIGHT ANGLE, DOUBLE ROW, AMPMODU 50/50 GRID CONNECTOR

108-1332

114-7010

00779 ©=104895

SCALE 5:1 SHEET 1 OF 1 REV H7