

REVISIONS					
P.	LTN	DESCRIPTION	DATE	DWN	APVD
A3		ECR-09-013545	11MAY2009	SR	AR
A4		REVISED PER ECR-09-026495	28NOV09	KK	AEK
A5		REVISED PER ECR-17-013084	08JAN2018	NC	MKO

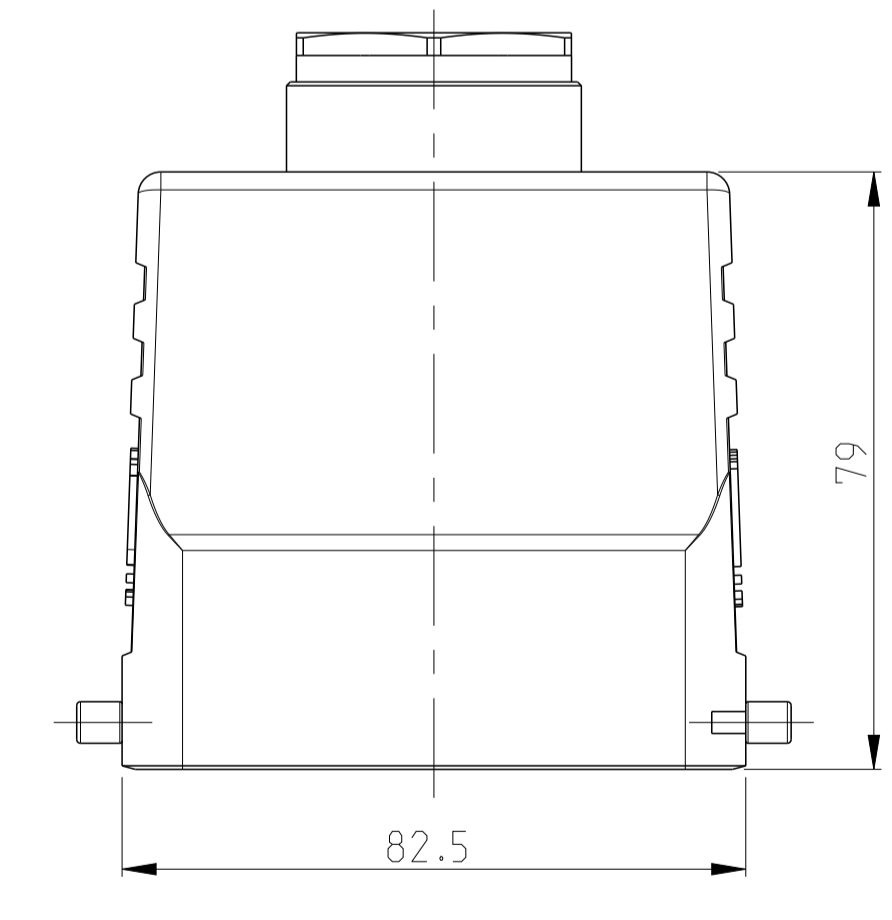
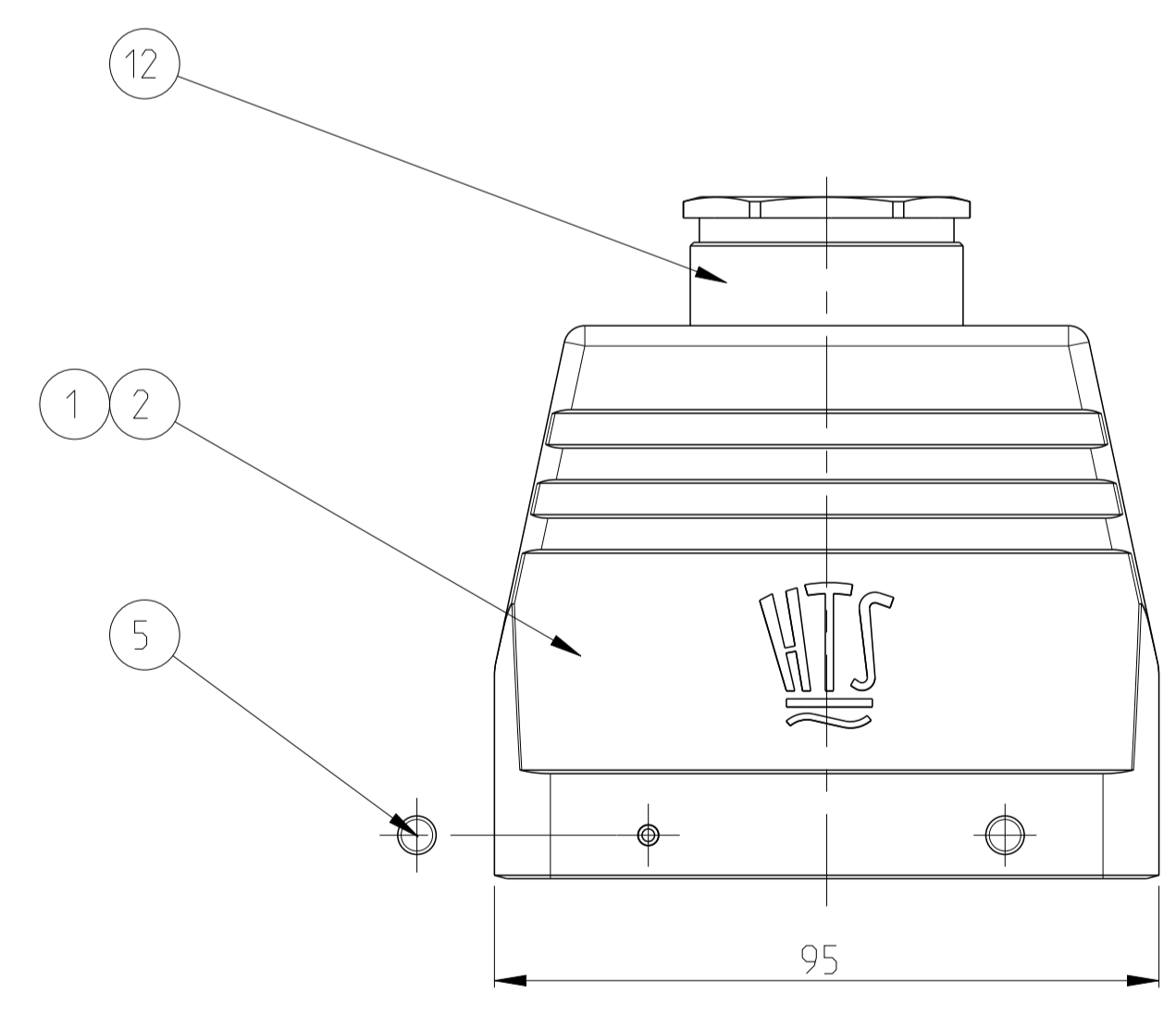
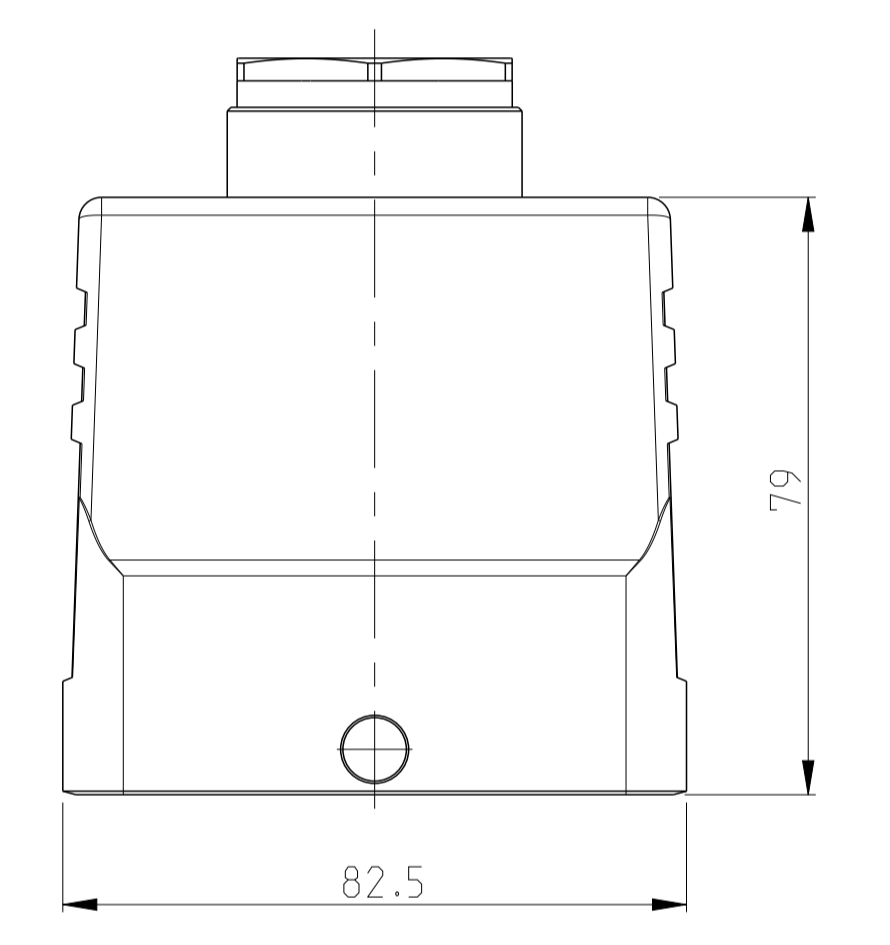
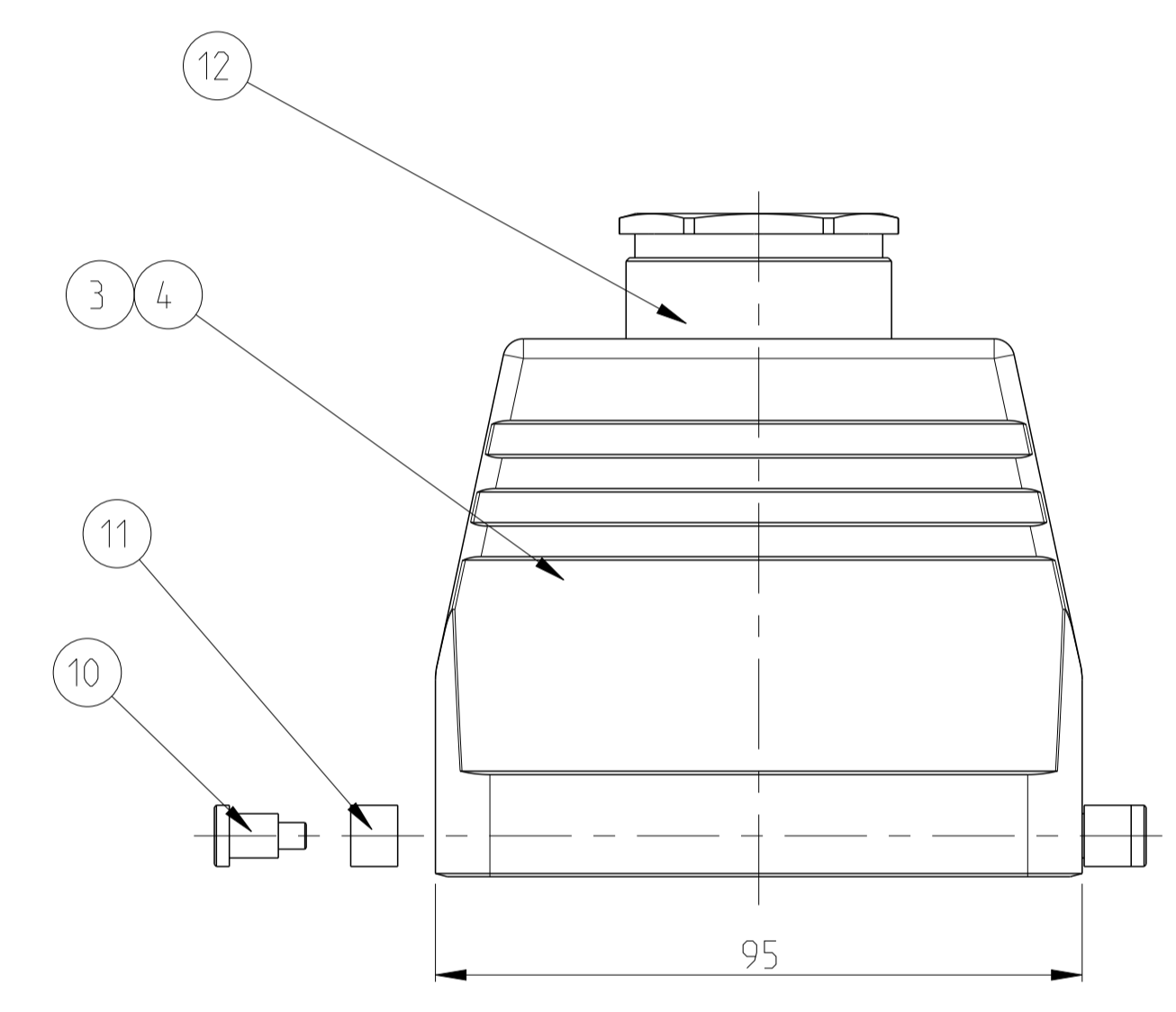
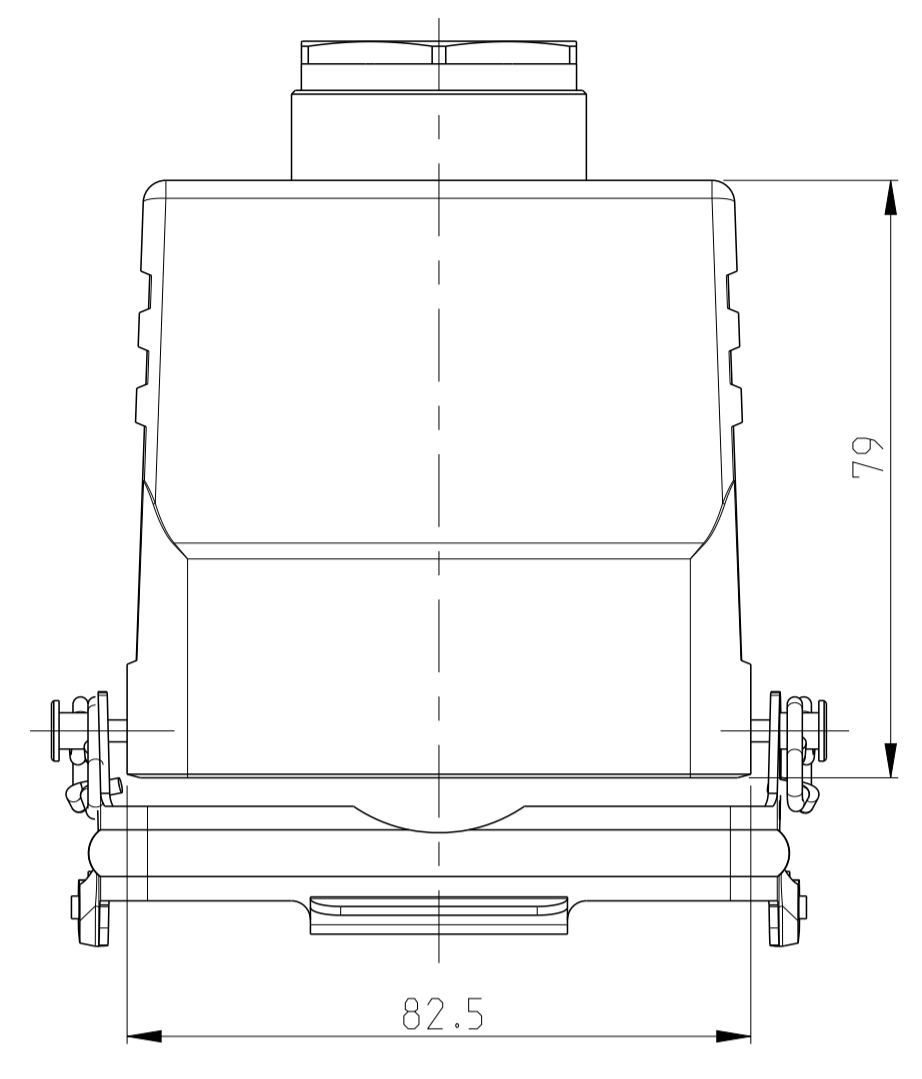
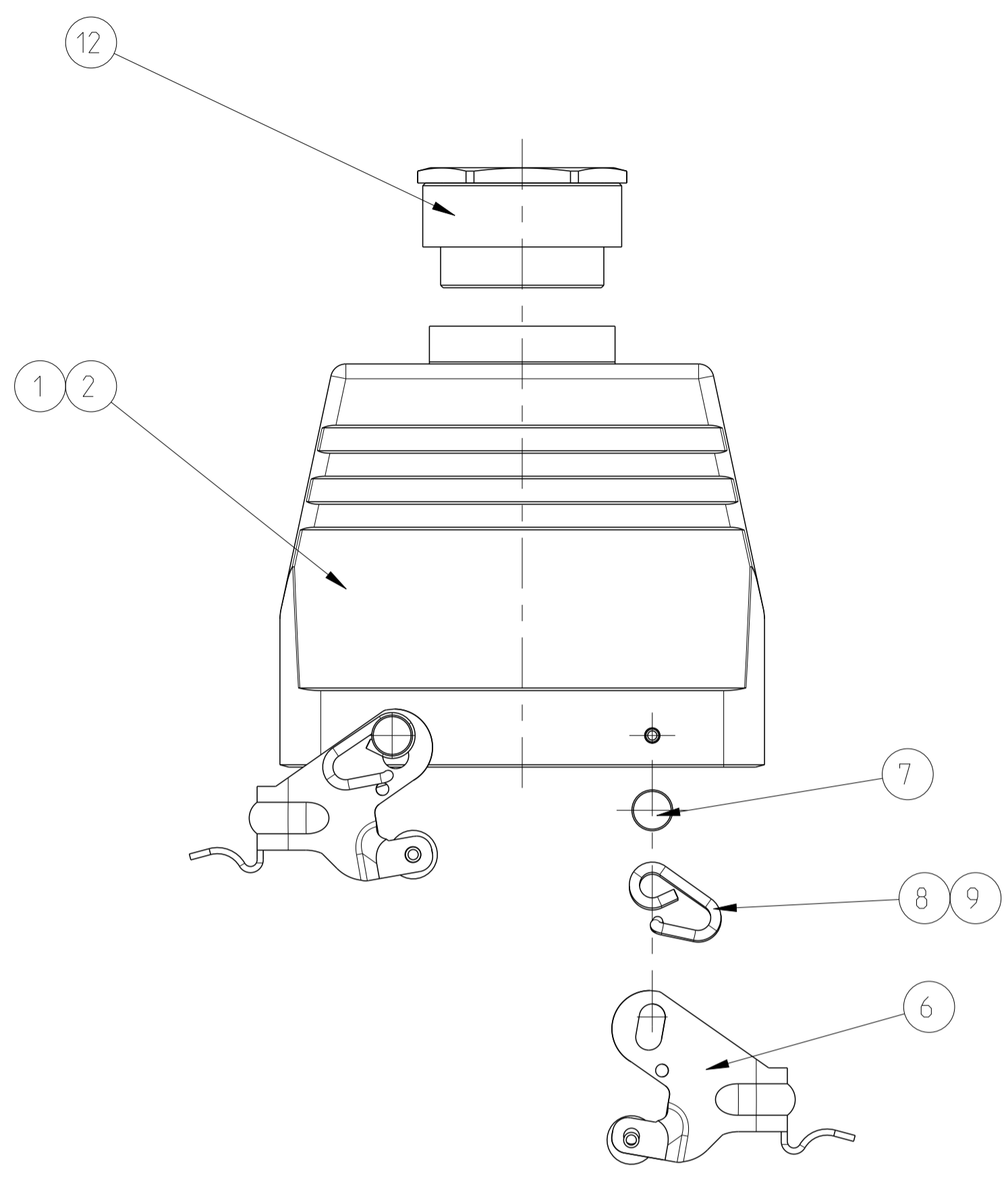

QTY	QTY	QTY	QTY	QTY	QTY	DESCRIPTION	MATERIAL	SURFACE	COLORE	ITEM	NOTES
1	1	1	1	1	1	CABLE FITTING	BRASS	NICKEL PLATED	BLUE	12	
2	2	2	2	2	2	SLIDE SPOOL	STEEL	ZINC PLATED	BLUE	11	
2	2	2	2	2	2	CLIP BOLT	STEEL	ZINC PLATED	BLUE	10	
		2	2	2	2	CLIP SPRING RIGHT	STEEL	ZINC PLATED	BLUE	9	
		2	2	2	2	CLIP SPRING LEFT	STEEL	ZINC PLATED	BLUE	8	
		4	4	4	4	CLIP POSITIONER	STEEL	ZINC PLATED	BLUE	7	
		2	2	2	2	SLIDE CLIP	STEEL	ZINC PLATED	BLUE	6	
				4	4	CLIP BOLT	STEEL	ZINC PLATED	BLUE	5	
1	1	1	1	1	1	HOOD	ALUMINIUM		GREY	4	
1	1	1	1	1	1	HOOD	ALUMINIUM		GREY	3	
		1	1	1	1	HOOD	ALUMINIUM		GREY	2	
				1	1	HOOD	ALUMINIUM		GREY	1	
0-2	1-7	0-3	1-1	0-1	1-6	DESCRIPTION	MATERIAL	SURFACE	COLORE	ITEM	NOTES
						HB.32.STO.1.29					
						HB.32.STO.1.29					
						HB.32.STO-VS.1.29					
						HB.32.STO-VS.1.29					
						HB.32.STO-GR.1.29					
						HB.32.STO-GR.1.29					

NOTES

- PART SHALL BE FREE AND CLEAN OF BURRS AND OTHER FOREIGN MATERIAL
- PACKAGING: QUANTITY 3 PIECES
- VARNISHING INSIDE HOUSING NOT REQUIRED

THIS DRAWING IS A CONTROLLED DOCUMENT. DWN: R.SCHNEIDER 11MAY2009
 CHK: T.SCHNURPFEL 11MAY2009

TE Connectivity

NAME: HOOD
 HB.32.STO.1.29

SCALE: 1:1 SHEET 1 OF 1 REV: A5