

THIS DRAWING IS UNPUBLISHED. RELEASED FOR PUBLICATION
 © COPYRIGHT - - ALL RIGHTS RESERVED.

REVISIONS				
P	LTR	DESCRIPTION	DATE	APVD
D1		REVISED PER ECR-19-001235	04FEB2018	BDA SV

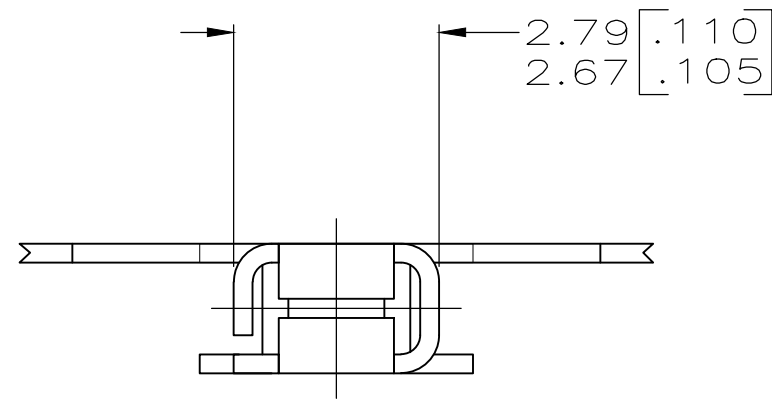

- 1 CONTINUOUS STRIP ON REELS WITH TERMINALS LOCATED ON 8.38±0.08 [.330±.003] CENTERS.
- 2 SLOT ACCEPTS EITHER A SINGLE OR DOUBLE MAGNET WIRE OF THE SAME SIZE AND TYPE.
COPPER RANGE: 0.29-0.32mm [#29-#28] AWG.
- 3 FITS A 0.508±0.025 [.020±.001] THICK TAB.

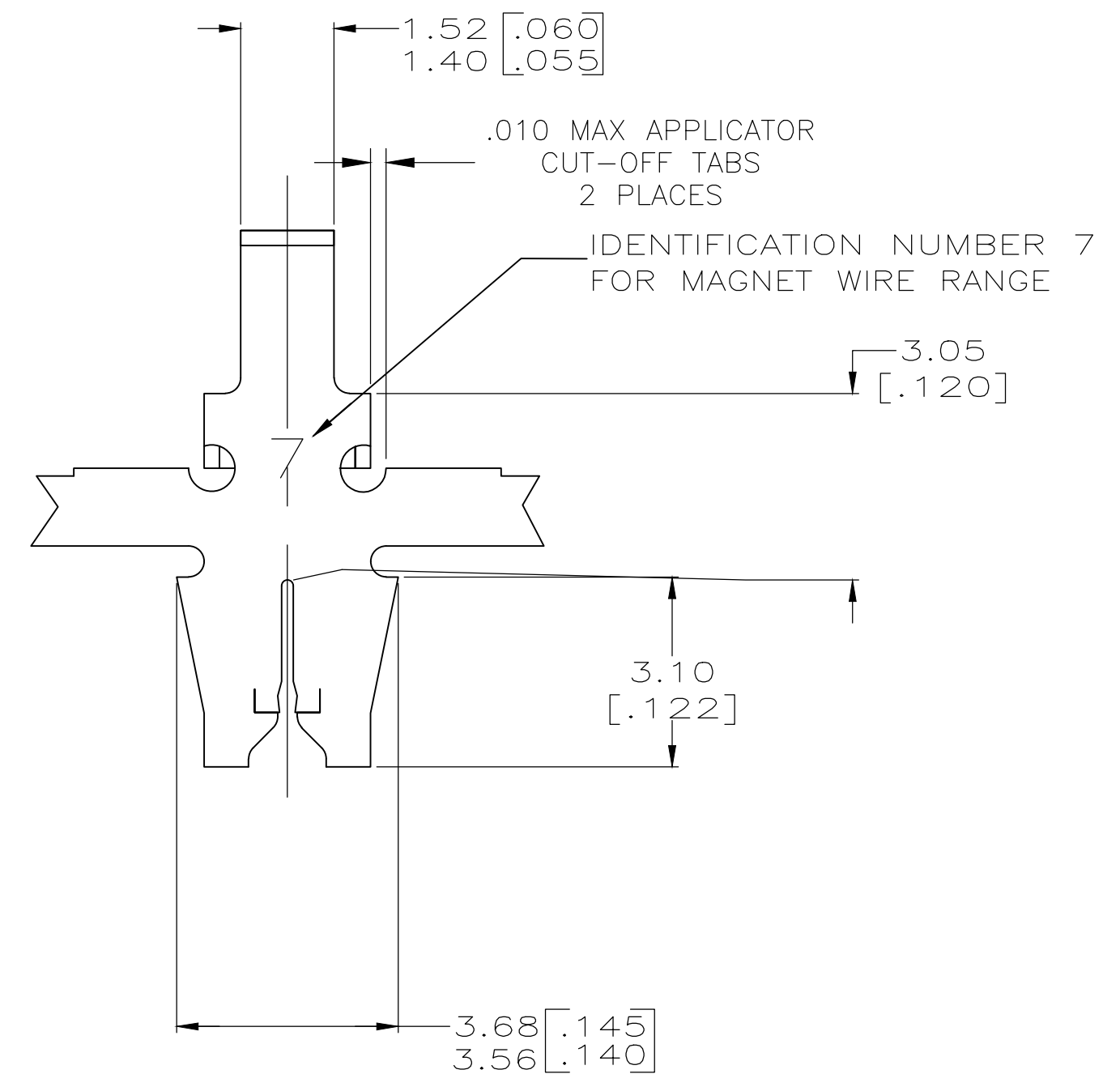
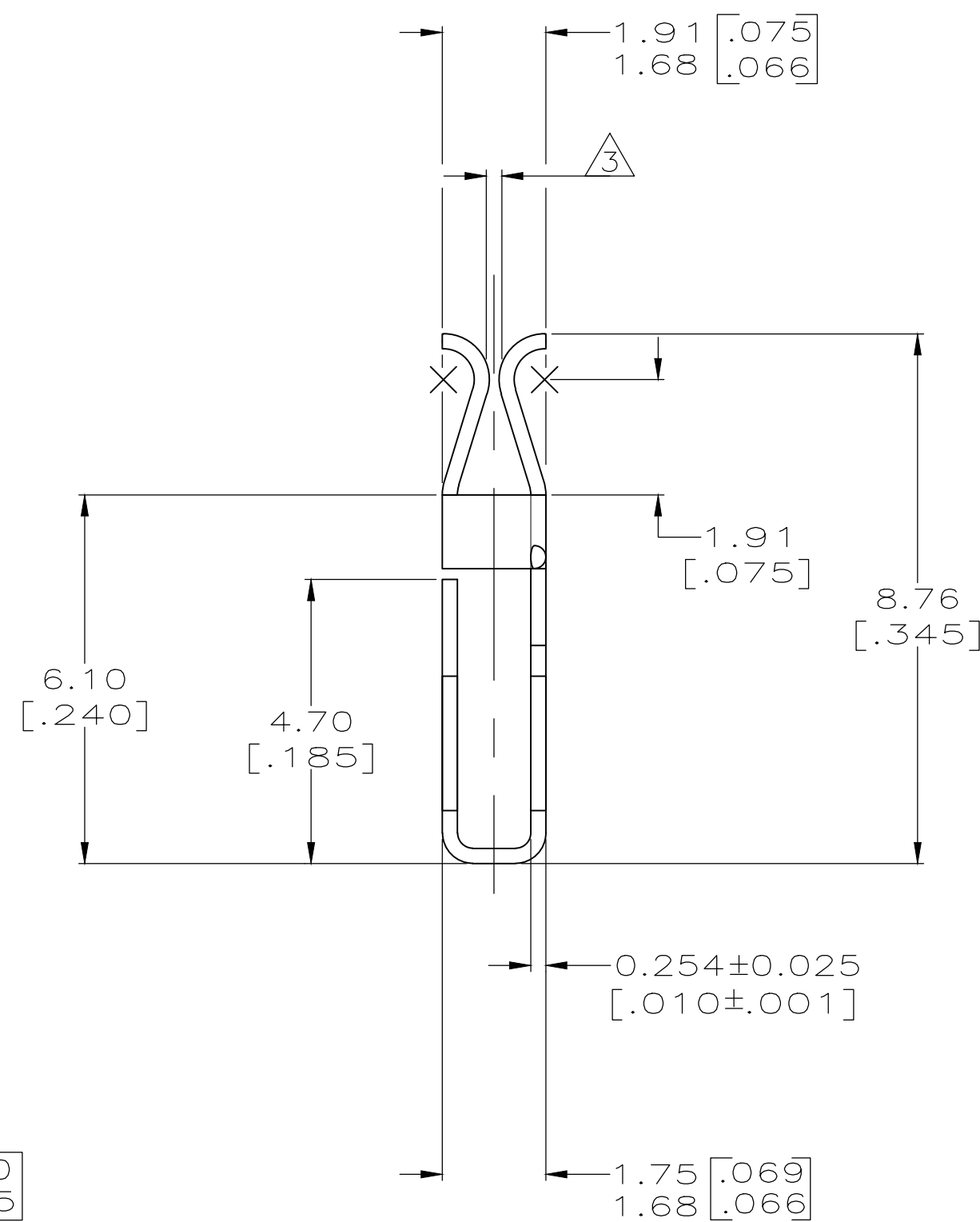
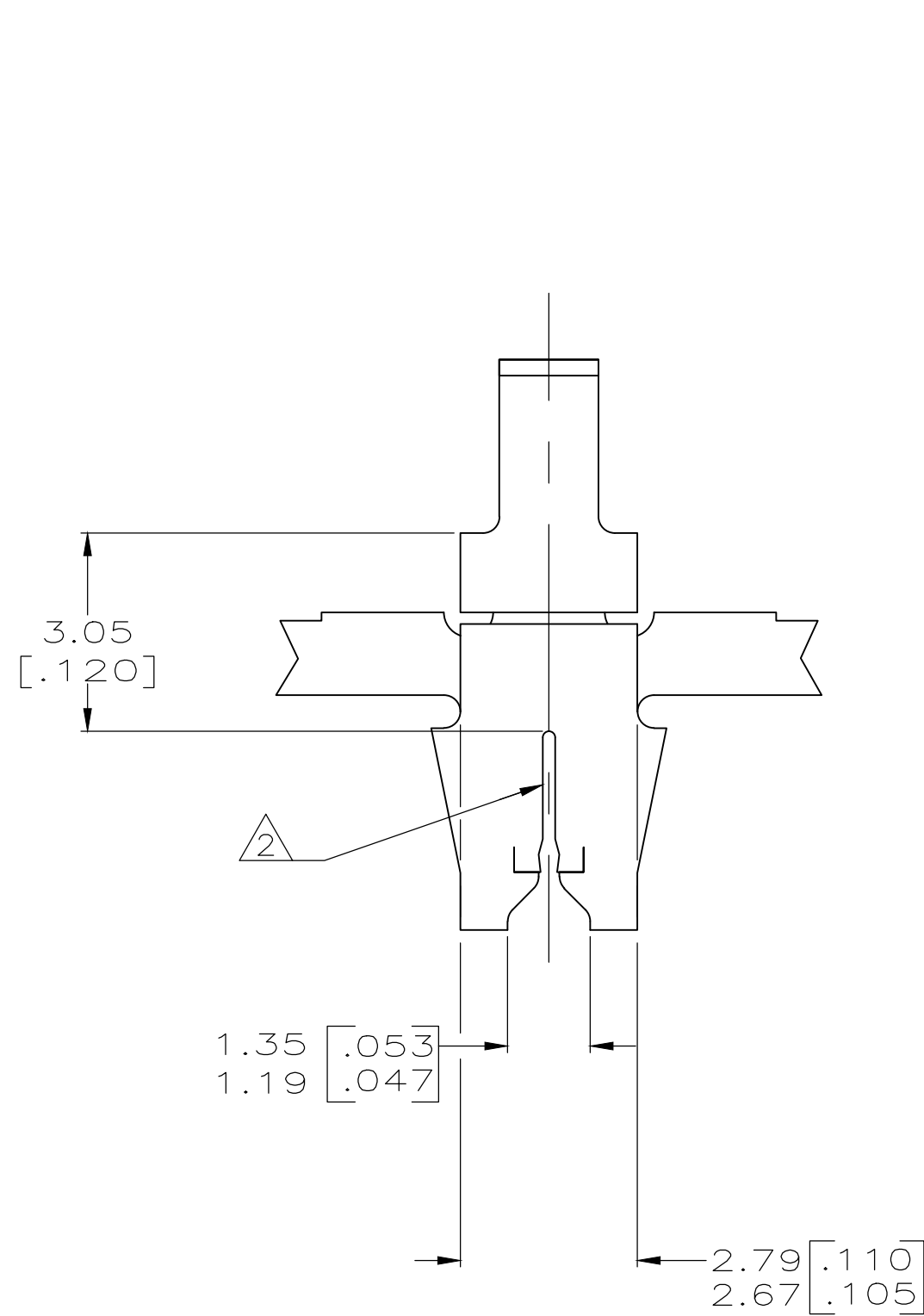

1217458-1
PART NUMBER

THIS DRAWING IS A CONTROLLED DOCUMENT.		DWN 03AUG2000 MICHAEL S. FEHER	TE Connectivity	
DIMENSIONS: INCHES		CHK 03AUG2000 KURT A. RANDOLPH		
TOLERANCES UNLESS OTHERWISE SPECIFIED:		APVD 03AUG2000 KURT A. RANDOLPH	NAME RECEPTACLE, TAB, MAG-MATE™	
0 PLC ± - 1 PLC ± - 2 PLC ± 0.25[.010] 3 PLC ± - 4 PLC ± - ANGLES ± -		PRODUCT SPEC 108-2012	SIZE A2	CAGE CODE 00779
MATERIAL H04 PHOS. BRONZE		FINISH TIN PLATE	DRAWING NO C=1217458	
		WEIGHT -	RESTRICTED TO -	
		CUSTOMER DRAWING		SCALE 10:1 SHEET 1 OF 1 REV D1

- 1217458