

THIS DRAWING IS UNPUBLISHED.

RELEASED FOR PUBLICATION

20

© COPYRIGHT 20 BY -

ALL RIGHTS RESERVED.

REVISIONS

P	LTR	DESCRIPTION	DATE	DWN	APVD
	A	INITIAL RELEASE	6JUN2016	Z.W	X.X
	B	ECR-18-009987	16JUL2018	Z.W	S.,M

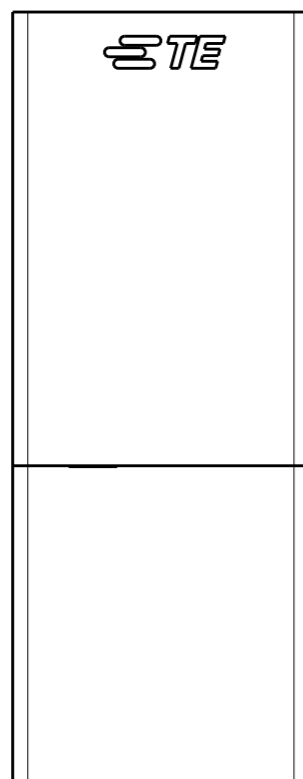

DATE CODE  
 YY WW X  
 ↑ ↑ ↑  
 YY=YEAR  
 EX: 15=2015  
 WW=WEEK  
 EX: 12=12  
 X=DAY  
 EX: 5=5

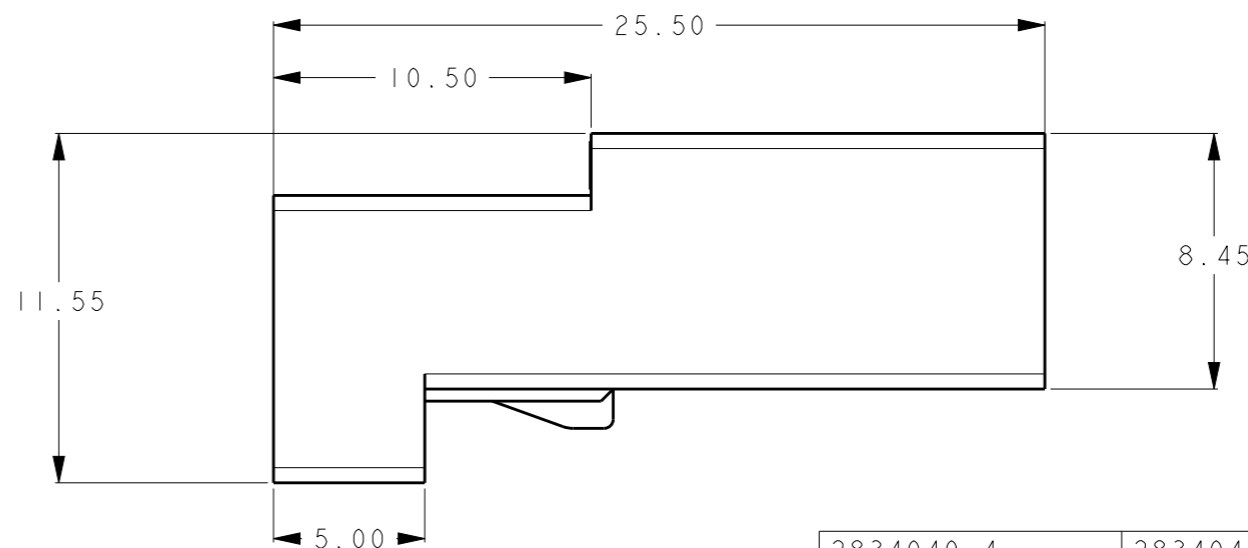
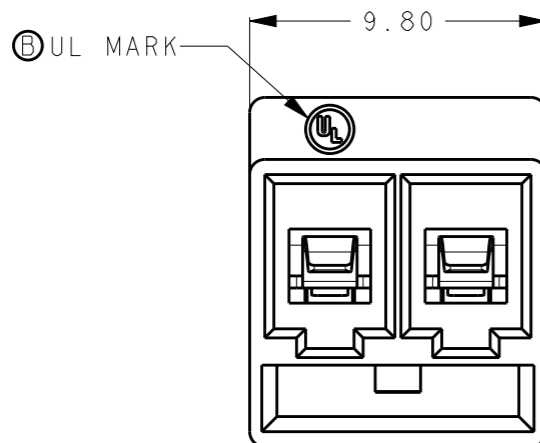
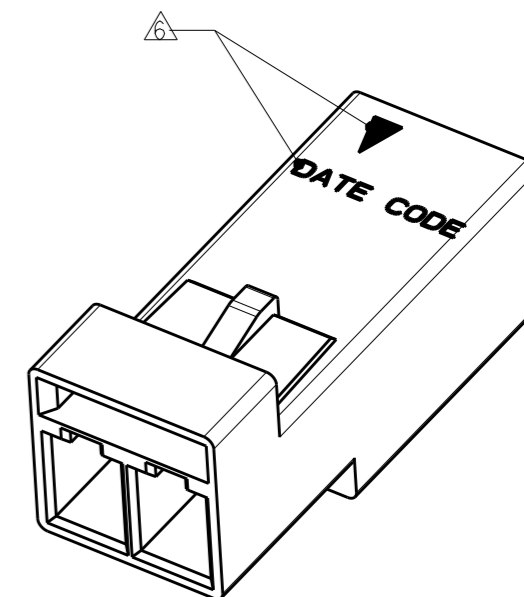
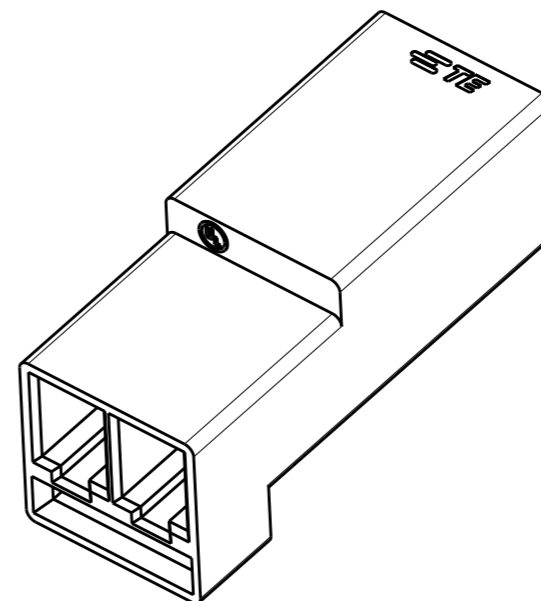

- NOTE:
- PART NUMBER: SEE TABLE.
  - MATERIAL:  
 TERMINAL: COPPER ALLOY  
 HOUSING: THERMOPLASTIC,UL94-V0.
  - FINISH  
 TERMINAL: TIN PLATING OVERALL.
  - PACKAGING: PLASTIC BAG.
  - APPLICABLE WIRE:  
 SOLID: 18-22AWG.  
 STRANDED WIRE: 16-20 AWG(26 STRANDS MAX. FOR 16 AWG  
 16 STRANDS MAX. FOR 18AWG, 7 STRANDS MAX. FOR 20AWG.  
 (14AWG: 7 STRANDS,16 AWG: 26 STRANDS, 18AWG:16STRANDS)
- △ MARK APPROXIMATION LOCATION.

AS SHOWN: 2834049-1/2/3/4

2834049-4	2834048-4	RED
2834049-3	2834048-3	ORANGE
2834049-2	2834048-2	BLACK
2834049-1	2834048-1	NATURAL
PART NUMBER	MATING SIDE P/N	PART COLOR

THIS DRAWING IS A CONTROLLED DOCUMENT.		DWN ZHANG WEI 18DEC2015	TE Connectivity <b>2 PIN LATCHED WIRE TO WIRE CONNECTOR          PLUG ASSEMBLY</b>	
DIMENSIONS: mm		CHK SHI MING 18DEC2015		
TOLERANCES UNLESS OTHERWISE SPECIFIED: ±0.50		APVD XU XIANG 18DEC2015		
0-PLC ± 1-PLC ± 2-PLC ± 3-PLC ± 4-PLC ± ANGLES ±1°		PRODUCT SPEC 108-137159		
MATERIAL -		FINISH -	APPLICATION SPEC 114-137159	NAME
		WEIGHT 1.65g	SIZE A300779	CAGE CODE C-2834049
		CUSTOMER DRAWING	SCALE 2:1	DRAWING NO -
			SHEET 1	OF 4
			REV B	RESTRICTED TO

REVISIONS

P	LTR	DESCRIPTION	DATE	DWN	APVD
		SEE SHEET 1			

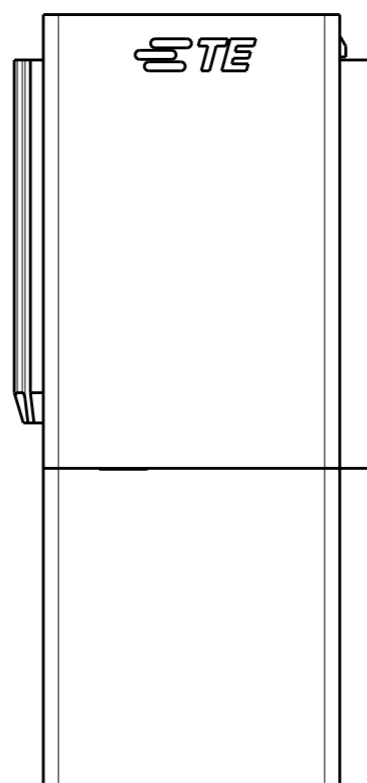

DATE CODE  
 YY WW X  
 ↑ ↑ ↑  
 YY=YEAR  
 EX: 15=2015  
 WW=WEEK  
 EX: 12=12  
 X=DAY  
 EX: 5=5

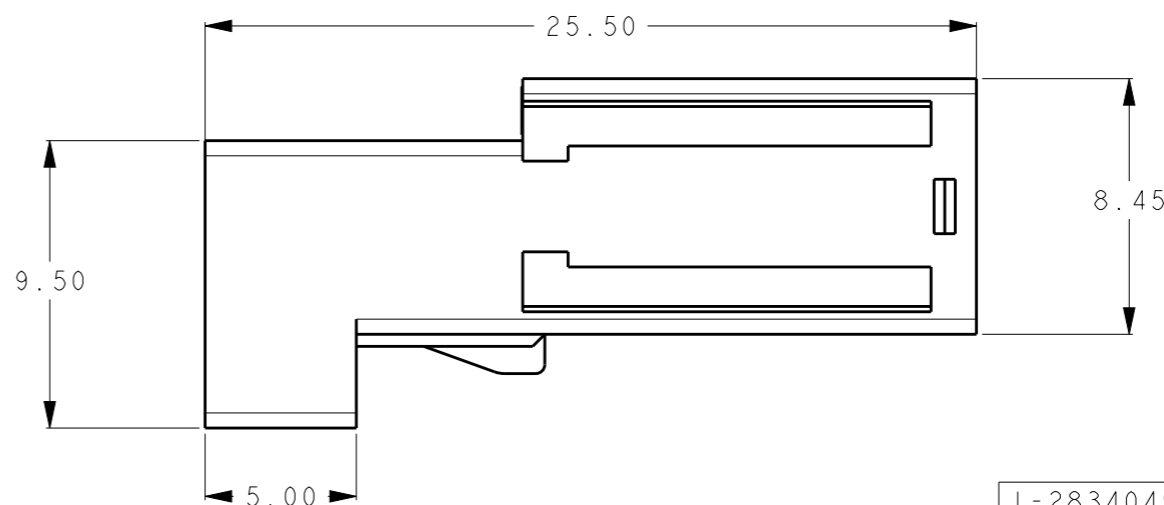
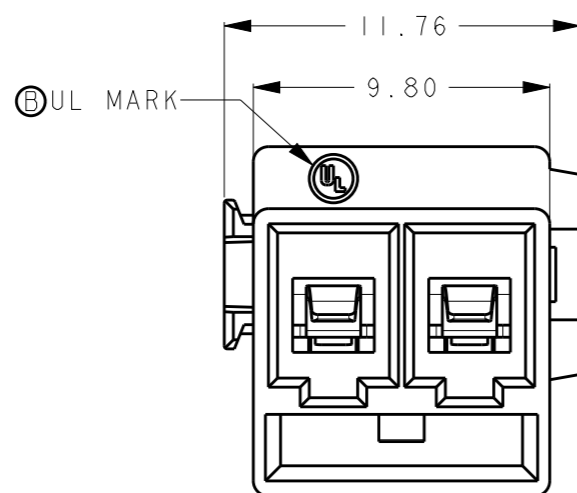
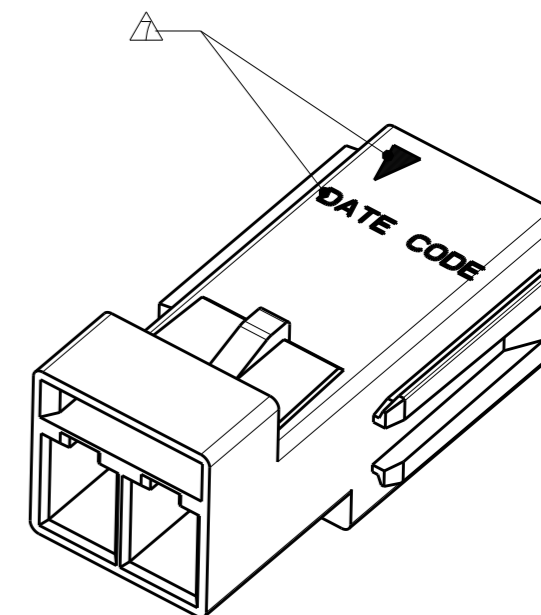
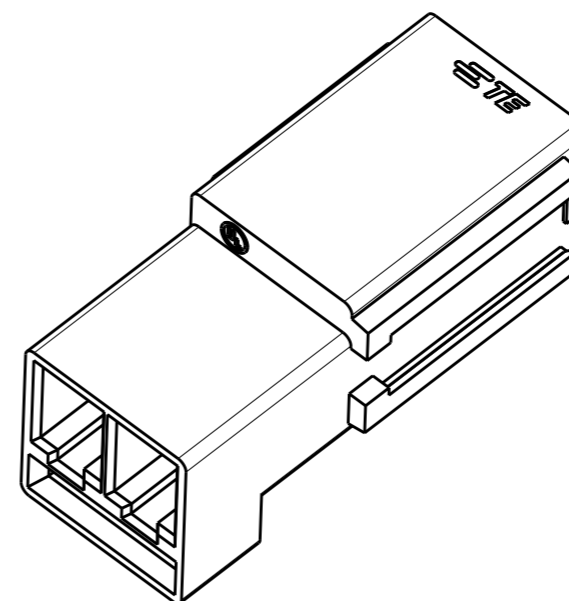

- NOTE:
- PART NUMBER: SEE TABLE.
  - MATERIAL:  
 TERMINAL: COPPER ALLOY  
 HOUSING: THERMOPLASTIC, UL94-V0.
  - FINISH  
 TERMINAL: TIN PLATING OVERALL.
  - PACKAGING: PLASTIC BAG.
  - APPLICABLE WIRE:  
 SOLID: 18-22AWG.  
 STRANDED WIRE: 16-20 AWG(26 STRANDS MAX. FOR 16 AWG  
 16 STRANDS MAX. FOR 18AWG, 7 STRANDS MAX. FOR 20AWG.  
 (14AWG: 7 STRANDS, 16 AWG: 26 STRANDS, 18AWG: 16STRANDS)
- △ MARK APPROXIMATION LOCATION.

I-2834049-4	RED
I-2834049-3	ORANGE
I-2834049-2	BLACK
I-2834049-1	NATURAL
PART NUMBER	PART COLOR

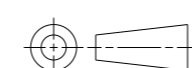
THIS DRAWING IS A CONTROLLED DOCUMENT.		DWN ZHANG WEI 18DEC2015	 TE Connectivity		
DIMENSIONS: mm		CHK SHI MING 18DEC2015			
TOLERANCES UNLESS OTHERWISE SPECIFIED: ±0.50		APVD XU XIANG 18DEC2015	NAME 2 PIN WIRE TO WIRE CONNECTOR PLUG ASSEMBLY		
		PRODUCT SPEC 108-137159	-		
MATERIAL -		APPLICATION SPEC 114-137159	SIZE A3	CAGE CODE 00779	DRAWING NO C-2834049
FINISH -		WEIGHT 1.71g	RESTRICTED TO		
		CUSTOMER DRAWING	SCALE 2:1	SHEET 2 OF 4	REV B

THIS DRAWING IS UNPUBLISHED.

RELEASED FOR PUBLICATION

20

© COPYRIGHT 20 BY -

ALL RIGHTS RESERVED.

REVISIONS

P	LTR	DESCRIPTION	DATE	DWN	APVD
		SEE SHEET 1			

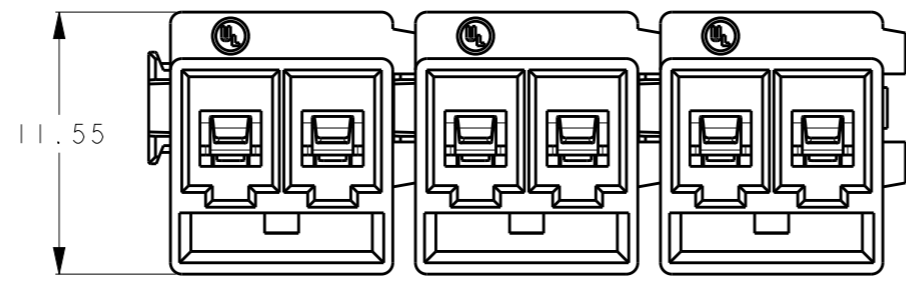
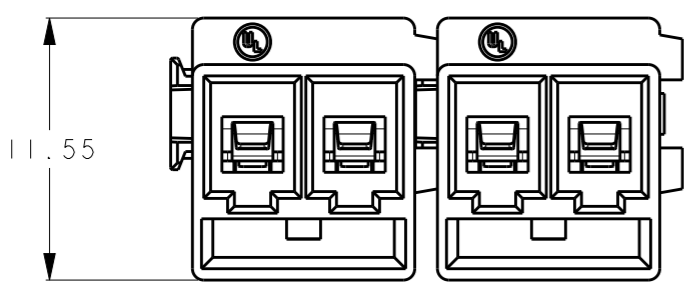
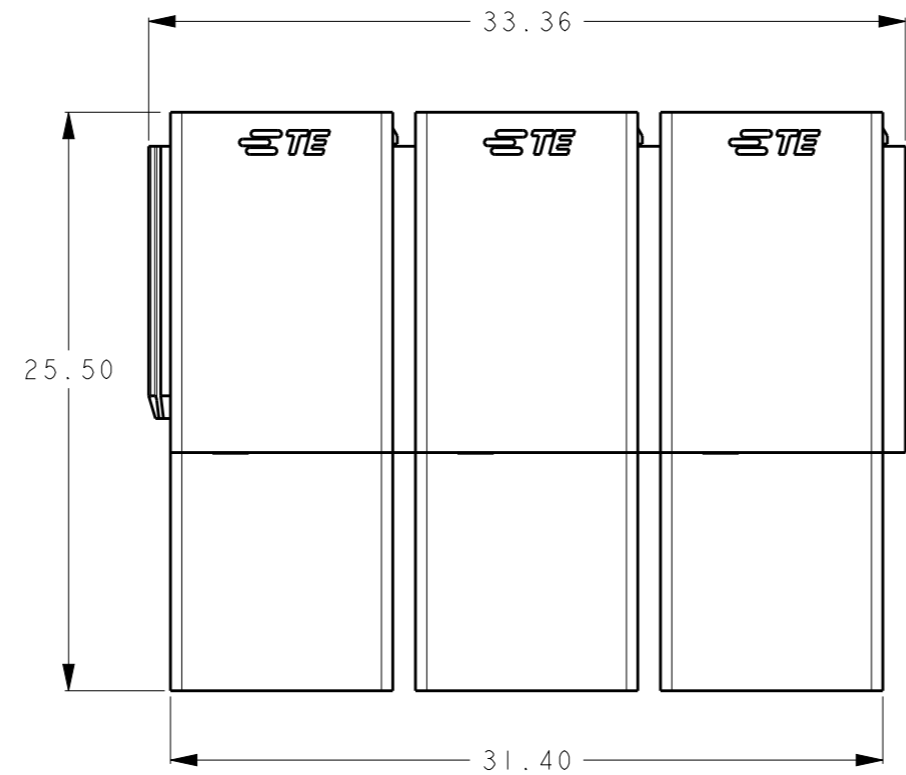
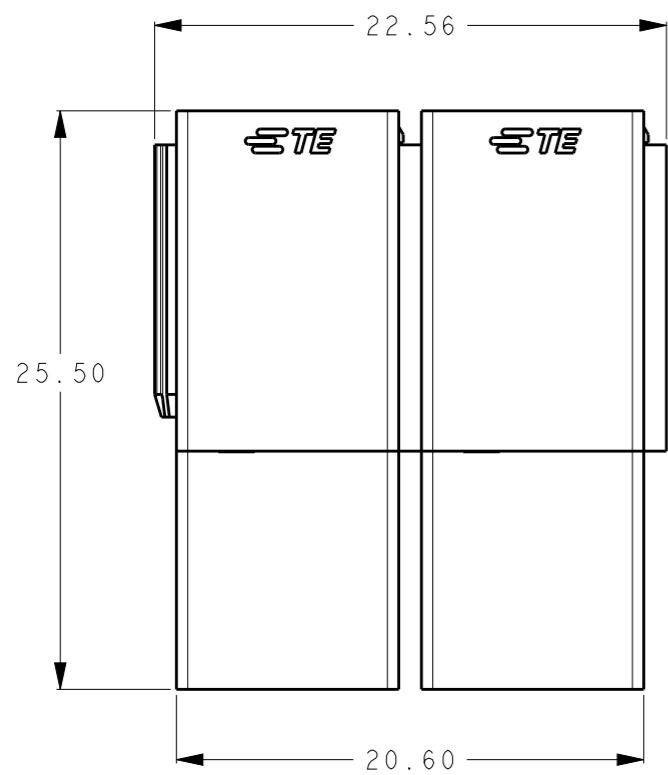

P/N: 2-2834049-1/2/3

P/N: 3-2834049-1/2

3-2834049-2	2P+2P+2P	ORANGE+BLACK+RED
3-2834049-1	MODULAR	NATURAL+BLACK+RED
2-2834049-3	2P+2P MODULAR	ORANGE+ORANGE
2-2834049-2		BLACK+RED
2-2834049-1		NATURAL+BLACK
PART NUMBER	DESCRIPTION	PART COLOR

THIS DRAWING IS A CONTROLLED DOCUMENT.

DIMENSIONS:	
mm	
TOLERANCES UNLESS OTHERWISE SPECIFIED:	
0-PLC	±0.50
1-PLC	±
2-PLC	±
3-PLC	±
4-PLC	±
ANGLES	±1°
MATERIAL	FINISH
-	-
-	-

DWN	18DEC2015
ZHANG WEI	
CHK	18DEC2015
SHI MING	
APVD	18DEC2015
XU XIANG	
PRODUCT SPEC	108-137159
APPLICATION SPEC	114-137159
WEIGHT	-
CUSTOMER DRAWING	

**STC** TE Connectivity

NAME  
2 PIN WIRE TO WIRE CONNECTOR  
PLUG ASSEMBLY

SIZE	CAGE CODE	DRAWING NO	RESTRICTED TO
A3	00779	C-2834049	

SCALE 2:1 SHEET 3 OF 4 REV B

THIS DRAWING IS UNPUBLISHED.

RELEASED FOR PUBLICATION

20

© COPYRIGHT 20 BY -

ALL RIGHTS RESERVED.

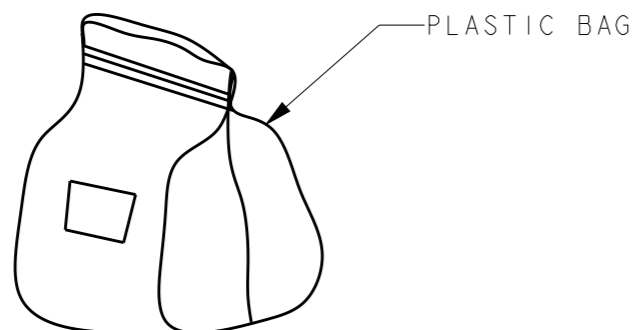
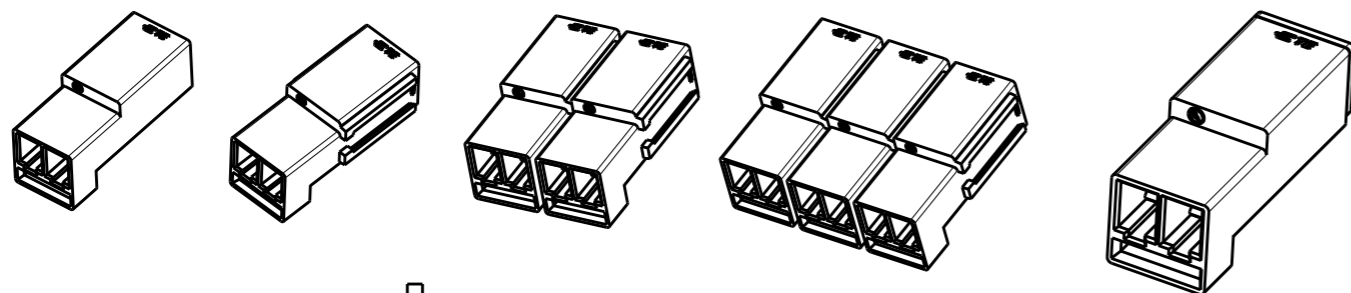

PLASTIC BAG

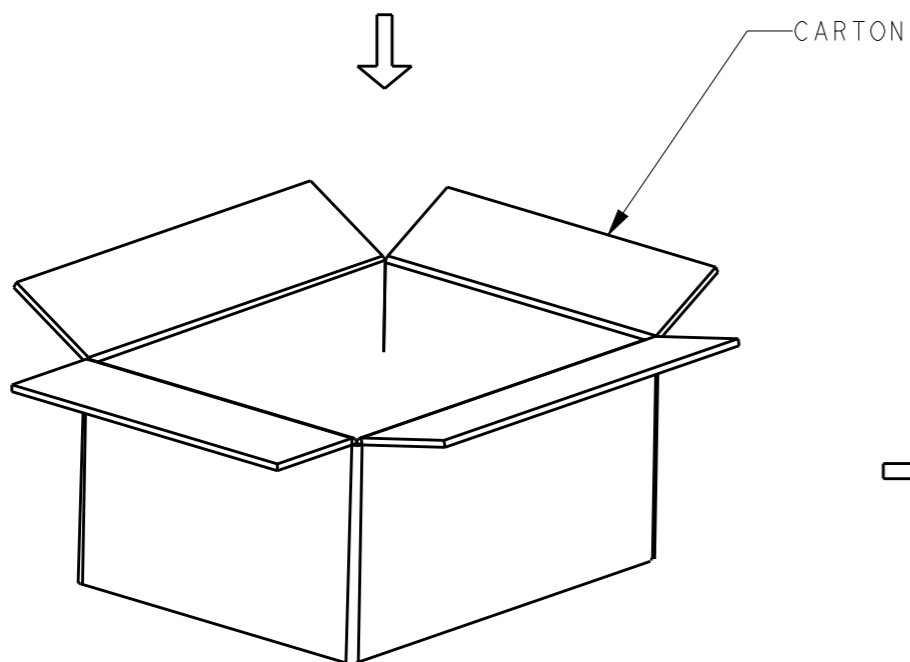

CARTON

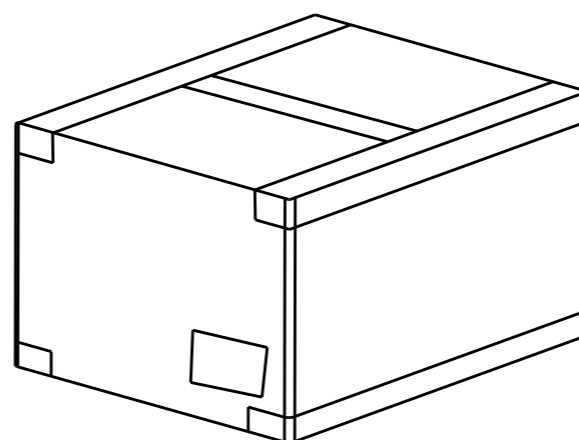

REVISIONS

P	LTR	DESCRIPTION	DATE	DWN	APVD
-		SEE SHEET 1	-	-	-

NOTE:  
1. PACKAGING QUANTITY: SEE TABLE.

PART NUMBER	PAIRS PER BAG	BAGS PER CARTON	PAIRS PER CARTON
2834049-*	500	8	4000

PART NUMBER	PAIRS PER BAG	BAGS PER CARTON	PAIRS PER CARTON
1-2834049-*	500	8	4000

PART NUMBER	PAIRS PER BAG	BAGS PER CARTON	PAIRS PER CARTON
2-2834049-*	300	8	2400

PART NUMBER	PAIRS PER BAG	BAGS PER CARTON	PAIRS PER CARTON
3-2834049-*	200	8	1600

PART NUMBER	PAIRS PER BAG	BAGS PER CARTON	PAIRS PER CARTON
4-2834049-*	500	8	4000

THIS DRAWING IS A CONTROLLED DOCUMENT.

DIMENSIONS:	TOLERANCES UNLESS OTHERWISE SPECIFIED:
mm	
	0 PLC ±
	1 PLC ±
	2 PLC ±
	3 PLC ±
	4 PLC ±
	ANGLES ± 1°
MATERIAL	FINISH
-	-
-	-

DWN	ZHANG WEI	18DEC2015
CHK	SHI MING	18DEC2015
APVD	XU XIANG	18DEC2015
PRODUCT SPEC	108-137159	
APPLICATION SPEC	114-137159	
WEIGHT	-	
CUSTOMER DRAWING		



NAME				2 PIN WIRE TO WIRE CONNECTOR PLUG ASSEMBLY	
SIZE				CAGE CODE	RESTRICTED TO
A300779		C=2834049			
SCALE			SHEET		REV
2:1			4 OF 4		B