

© COPYRIGHT 1978 BY AMP INCORPORATED, HARRISBURG, PA. ALL INTERNATIONAL RIGHTS RESERVED. AMP INCORPORATED PRODUCTS COVERED BY U. S. AND FOREIGN PATENTS AND/OR PATENTS PENDING.

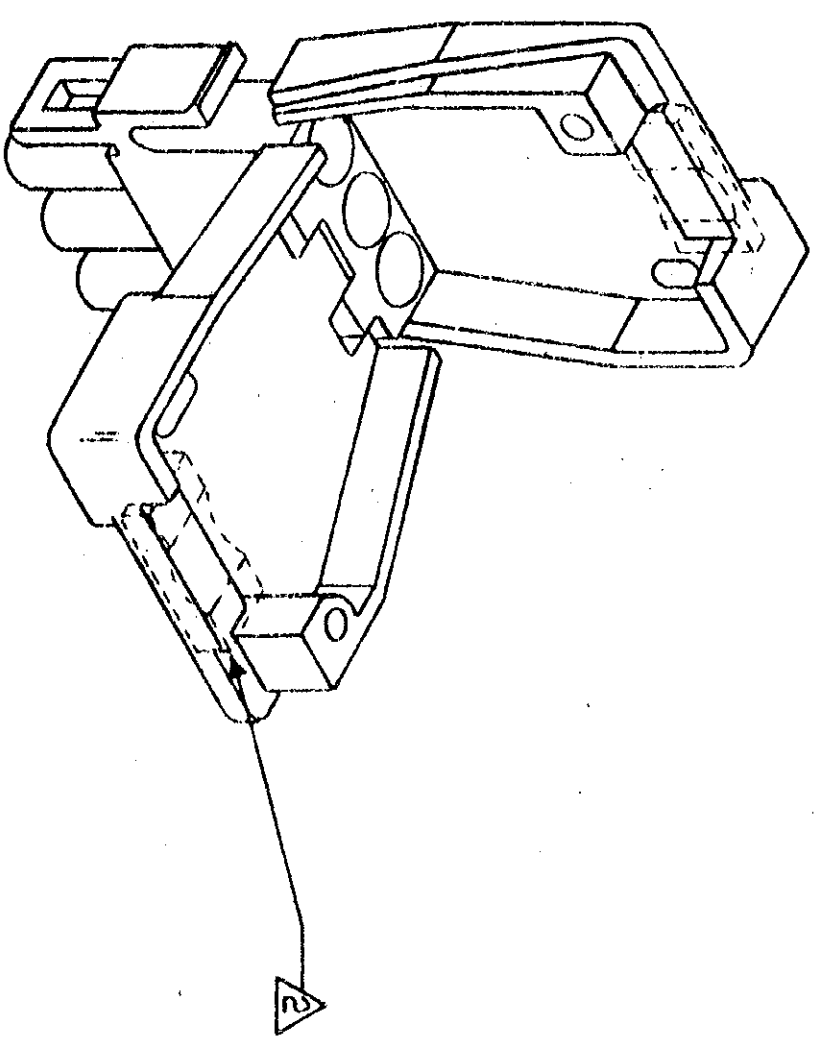
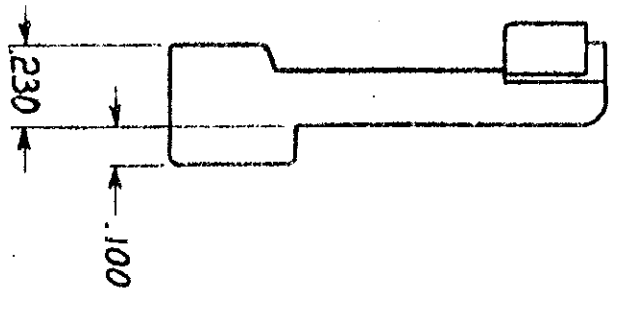
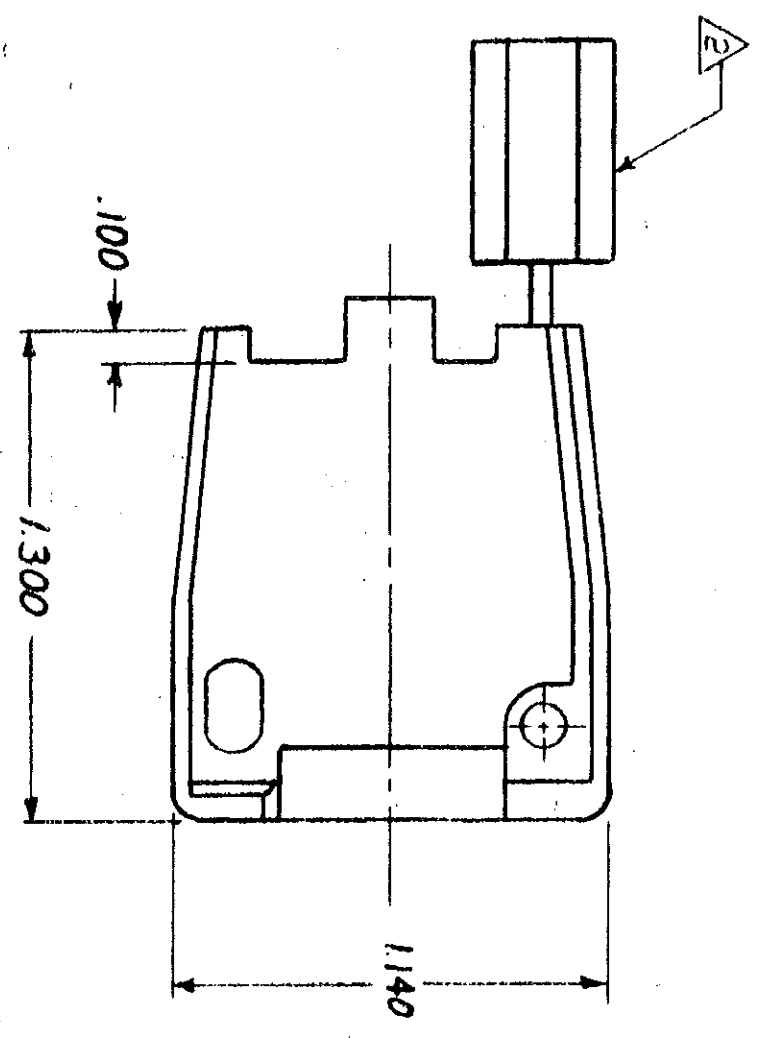
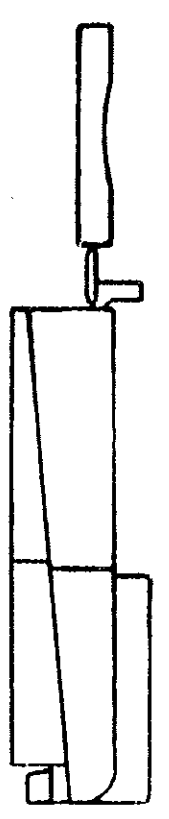

(2 REQ'D) #6x.375 L.S. TYPE 'B' PAN HEAD SHEET METAL SCREW

- 1 SHEET METAL SCREWS NOT SUPPLIED.
- 2 INSERT IS ATTACHED TO STRAIN RELIEF. AS AN ADDITIONAL ADJUSTMENT FOR SMALL WIRE BUNDLES, IT SHOULD BE CUT OFF AND POSITIONED AS SHOWN BY DOTTED LINES.
- 3 TWO REQUIRED PER CONNECTOR.
- 4 DETACHABLE INSERT MAY SEPARATE FROM STRAIN RELIEF BODY DURING SHIPPING.

REV	ZONE	TR	DESCRIPTION	DATE	APPROVED
0			DRWG RELEASED PER M-5037	10-23-78	CE/BA
1			CHANGED SCREW LENGTH PER M-5385	6-25-79	MSE/BA
2			AI RESTORATION	6-24-83	SS/BA
3			REV PER ECN CM 705	12-2-86	TS/RS

WIRE BUNDLE	
WITHOUT INSERT	3 @ .190 DIA
WITH INSERT	3 @ .040 DIA

UNLESS OTHERWISE SPECIFIED DIMENSIONS ARE IN INCHES. TOLERANCES ON: DECIMALS ± .015 ANGLES

CONTRACT NO. C. ERSIMAN 10-24-78  
 DR. C. ERSIMAN 11/1/78  
 CHK. J.S. Steide 11-1-78  
 APPD. J.C.M. 11-1-78  
 APPD. J.C.M. 11-1-78

NAME: STRAIN RELIEF AND INSERT, 3 CIRCUIT, UNIVERSAL MATE-N-LOK™  
 MATERIAL: NYLON 94V-2  
 COLOR: NATURAL  
 PART NO: A1-640720-0

FINISH: SEE TABLE  
 DSGN APPD: SEE TABLE  
 OTHER APPD:  
 SIZE CODE: C  
 IDENT NO: 00779  
 DRAWING NO: 640720  
 SCALE: NTS  
 SHEET: 1 OF 1

640720

640720