

THIS DRAWING IS UNPUBLISHED.

RELEASED FOR PUBLICATION

20

© COPYRIGHT 20 BY -

ALL RIGHTS RESERVED.

REVISIONS

P	LTR	DESCRIPTION	DATE	DWN	APVD
	B	PER ECR-19-016418	22OCT2019	BW	RS

2061953-1 AS SHOWN

ASSEMBLED FULLAXS MINI BULKHEAD CAP WITH EMI SHIELD

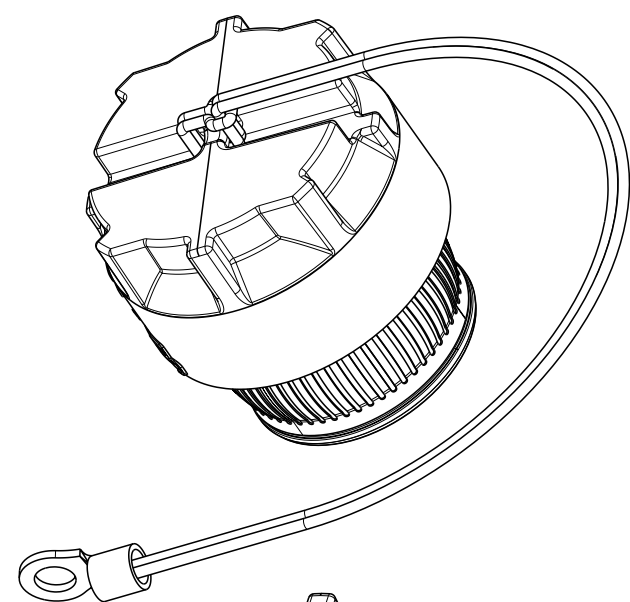

2061953-2 AS SHOWN

ASSEMBLED FULLAXS MINI BULKHEAD CAP

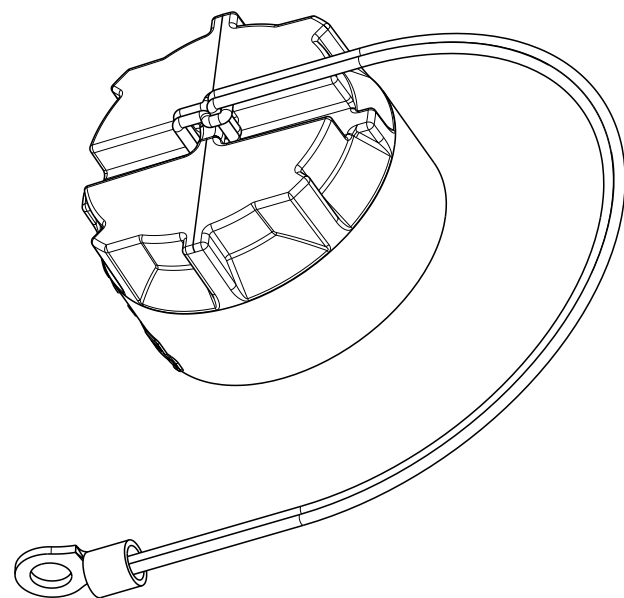

2061953-3 AS SHOWN

ASSEMBLED FULLAXS MINI BULKHEAD CAP WITHOUT CORD

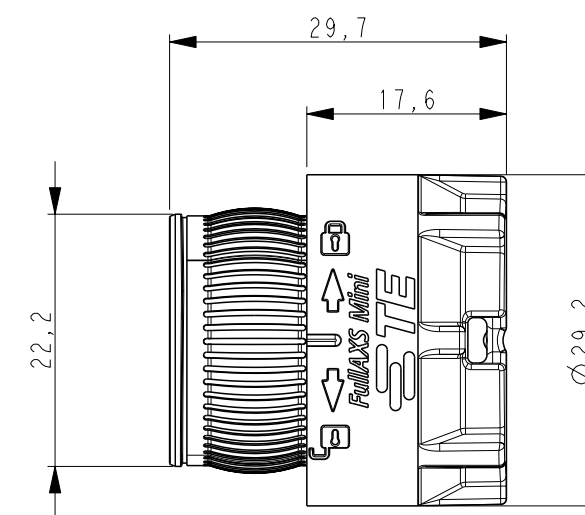
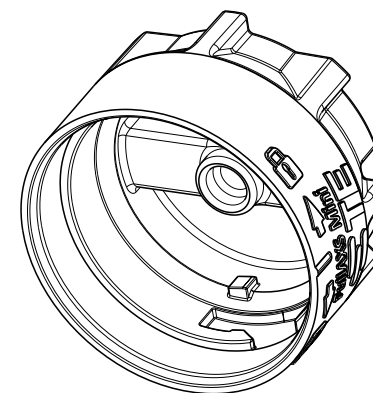
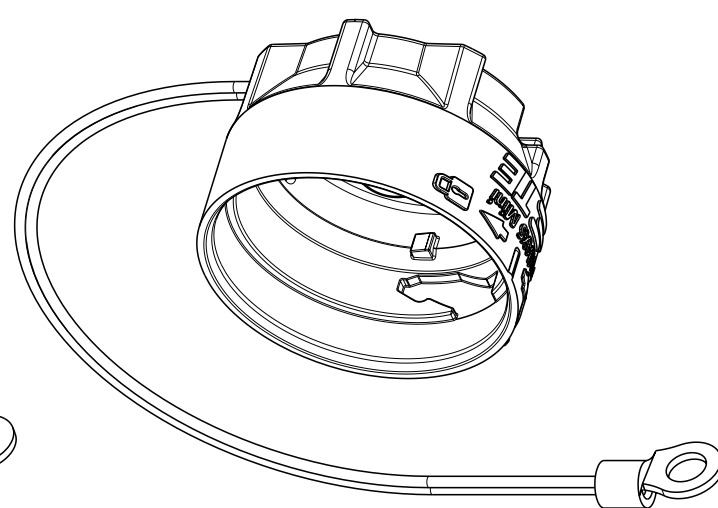
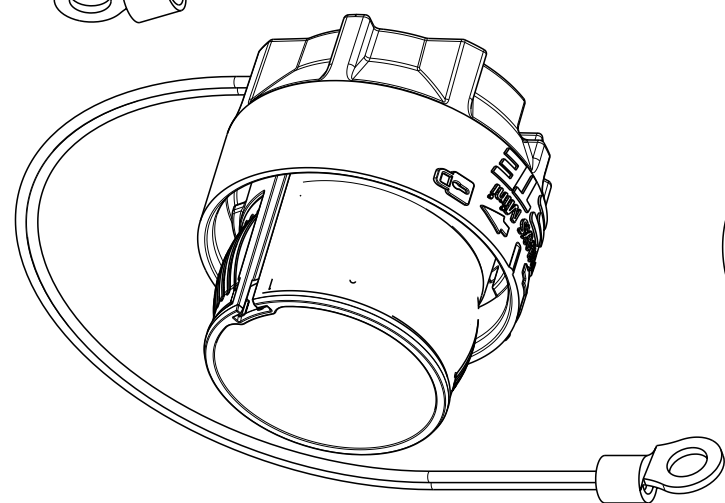
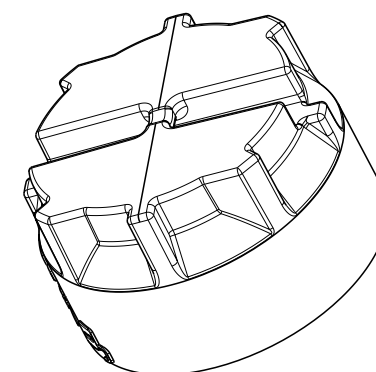

NOTES:

- PACKAGING:
 - QTY 10 CAPS PLACED INTO A ESD BAG.
 - QTY 10 BAGS PLACED INTO A SHIPPING BOX
- INFORMATION ON PACKAGING LABEL:
 - BARCODE
 - UNIQUE TE SERIAL NUMBER
 - TE CONNECTIVITY PART NUMBER & ORDER NUMBER

THIS DRAWING IS A CONTROLLED DOCUMENT.

DIMENSIONS:
mm

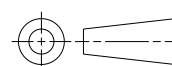

TOLERANCES UNLESS OTHERWISE SPECIFIED:

0 PLC	±0,2
1 PLC	±0,1
2 PLC	±0,05
3 PLC	±0,025
4 PLC	±0,005
ANGLES	±2°

MATERIAL

FINISH

DWN 24MAR2015

R. COOLEN

CHK 24MAR2015

B. MOOIJ

APVD 24MAR2015

S. BORGAS

PRODUCT SPEC

APPLICATION SPEC

WEIGHT

CUSTOMER DRAWING



TE Connectivity

NAME

FULLAXS MINI BULKHEAD CAP

SIZE

A3

CAGE CODE

-

DRAWING NO

C-2061953

RESTRICTED TO

-

SCALE 1:1

SHEET 1 OF 1

REV B