

LOC	DIST	REVISIONS					
		P	LTN	DESCRIPTION	DATE	DWN	APVD
GP	00	1		PRELIMINARY	19SEP2012	DZ	JY

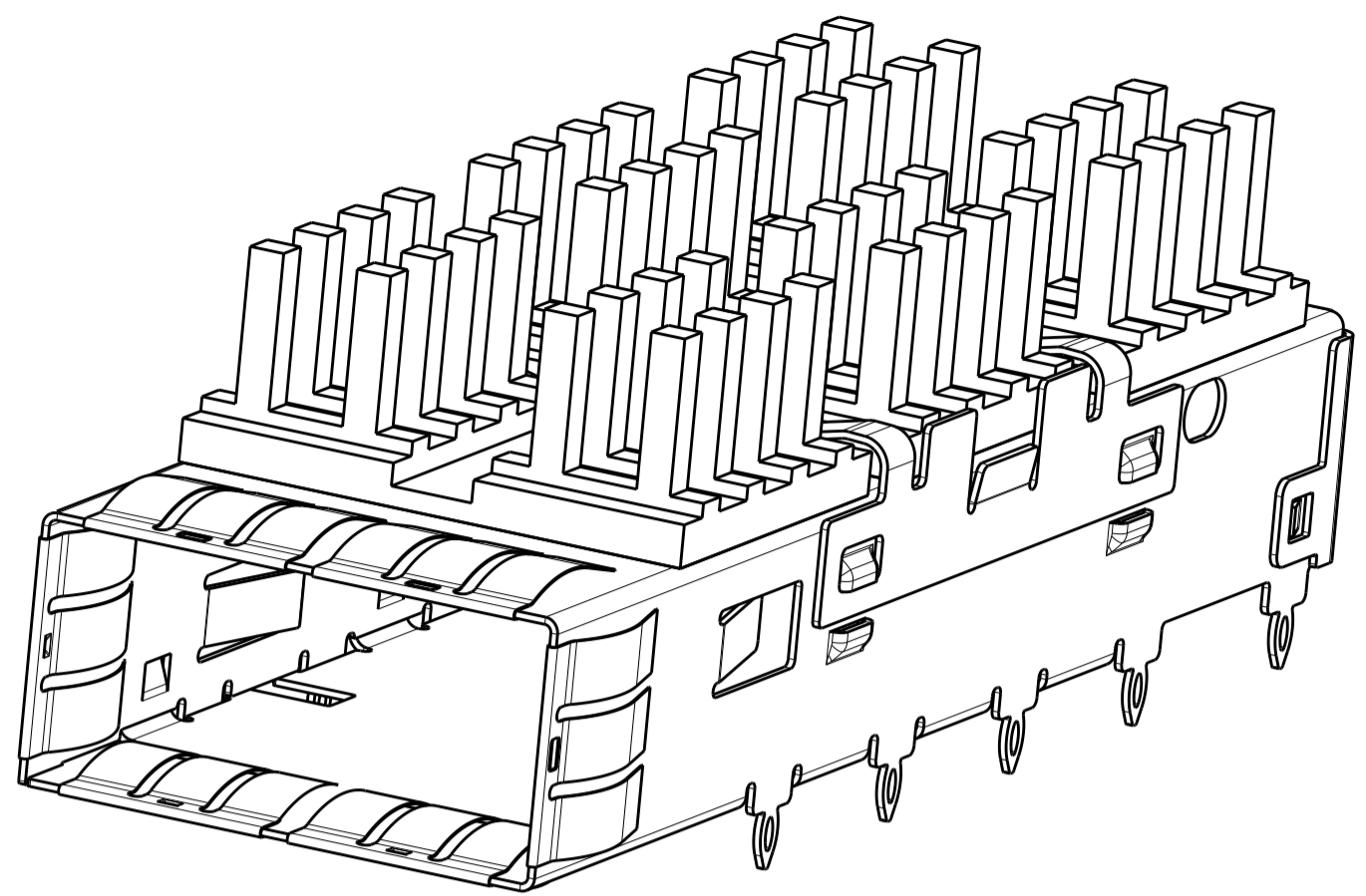

SCALE 4:1

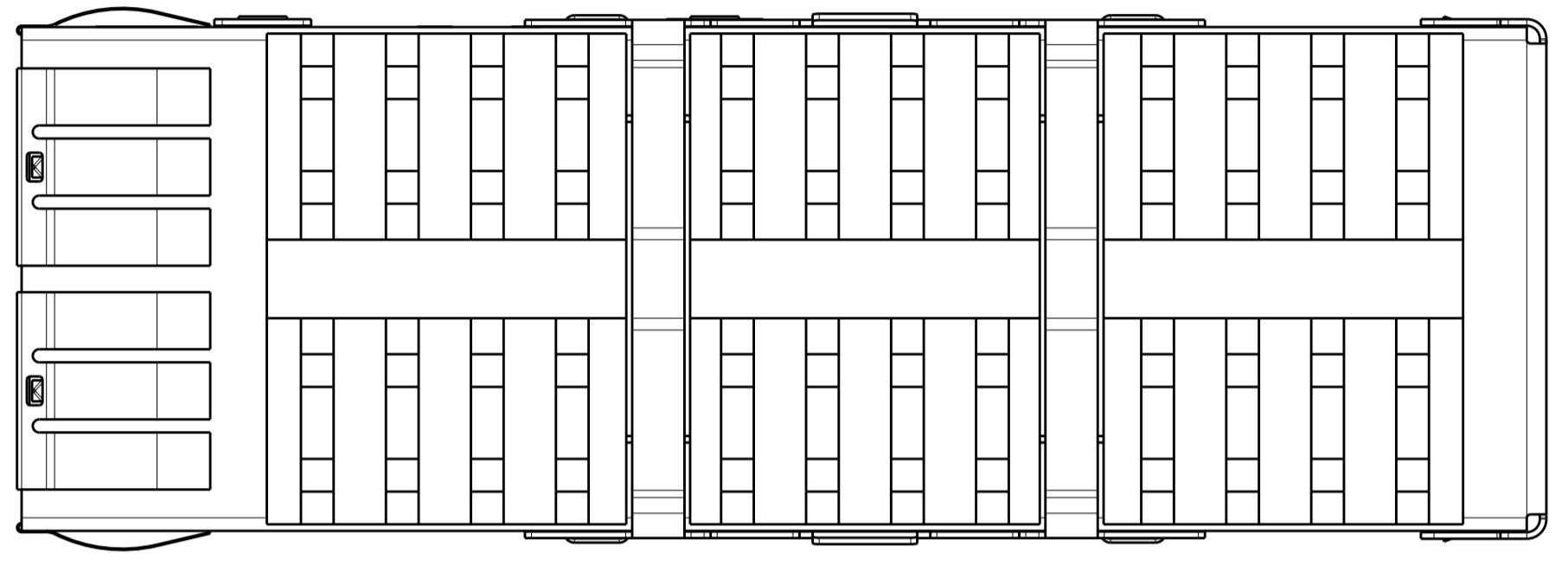

- 1. CAGE MATERIAL: NICKEL SILVER, 0.25 THICK
 HEAT SINK MATERIAL: ALUMINUM
 HEAT SINK CLIP MATERIAL: STAINLESS STEEL
 EMI SPRINGS MATERIAL: COPPER ALLOY
- 2. MINIMUM PITCH DIMENSION.
- 3. MATES WITH QSFP MSA COMPATIBLE TRANSCEIVER.
- 4. REFERENCE APPLICATION SPEC 114-13217 FOR RECOMMENDED DRILL HOLE DIAMETER AND PLATING THICKNESS.
- 5. DATUMS AND BASIC DIMENSIONS ESTABLISHED BY CUSTOMER.
- 6. MINIMUM PC BOARD THICKNESS:
 SINGLE SIDED = 1.45mm (shown, pg. 4)
 DOUBLE SIDED = 2.2mm
- 7. HEATSINK AND CLIP SHIPPED ASSEMBLED TO CAGE ASSEMBLY. CAGE ASSEMBLY MAY BE PRESSED INTO THE PCB AS SHIPPED.
- 8. DATUM -A- IS TOP SURFACE OF HOST BOARD.
- 9. SURFACE TRACES PERMITTED WITHIN THIS AREA EXCEPT WHERE CAGE STANDOFFS, SHOWN IN DETAIL J, CONTACT PC BOARD.
- 10. DIMENSION APPLIES WITH MODULE INSTALLED IN THE CAGE.
- 11. DATE CODE MARKED ON TOP OF CAGE AND CONCEALED BY HEAT SINK APPLIES TO CAGE ASSEMBLY ONLY.
- 12. SPRING FINISH: 0.8um MIN TIN OVER 0.8um MIN NICKEL. NON-PLATED EDGES PERMISSIBLE.
 HEAT SINK FINISH: 0.076 um MIN NICKEL.

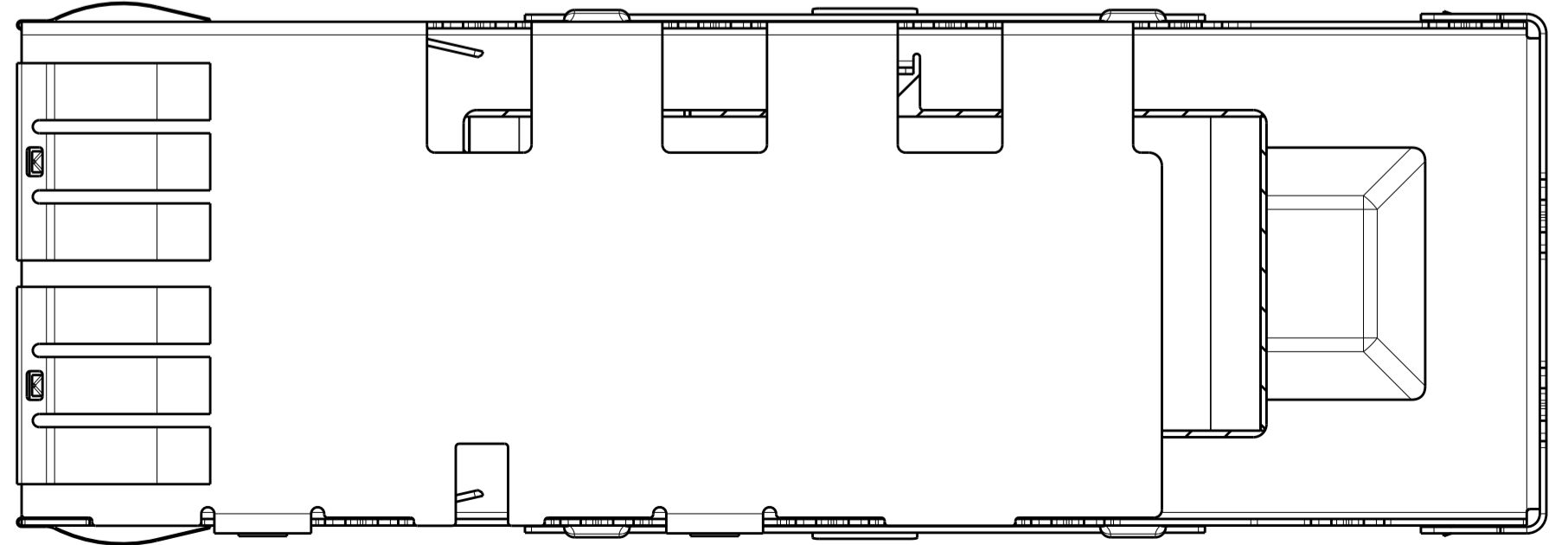
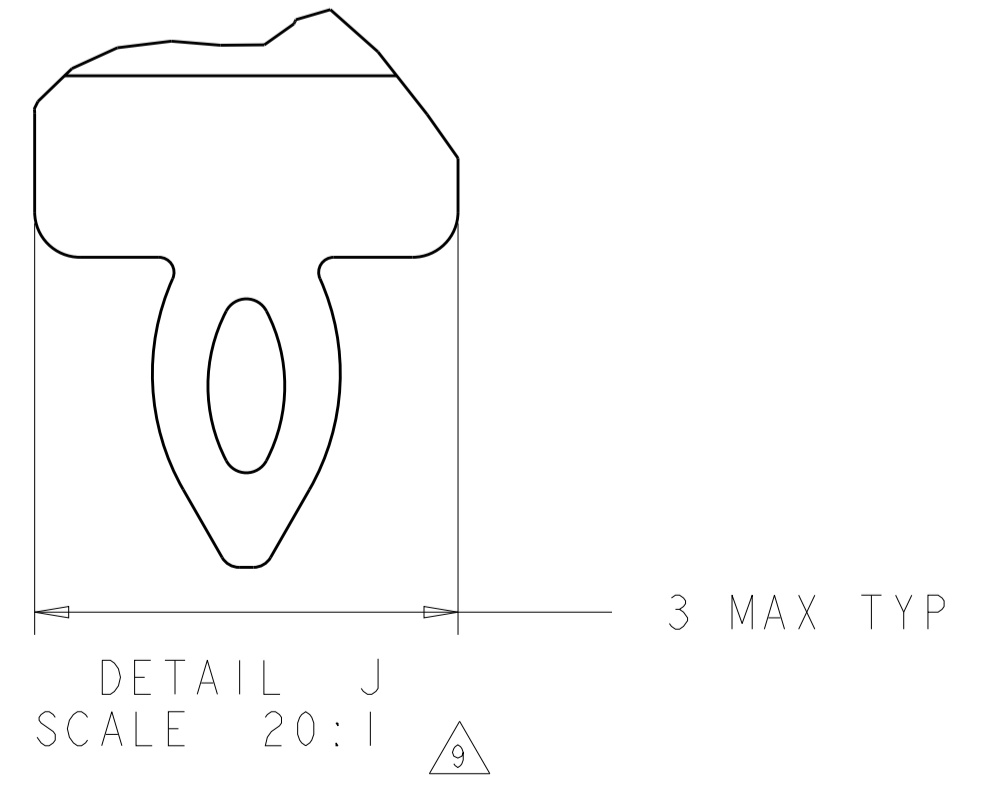
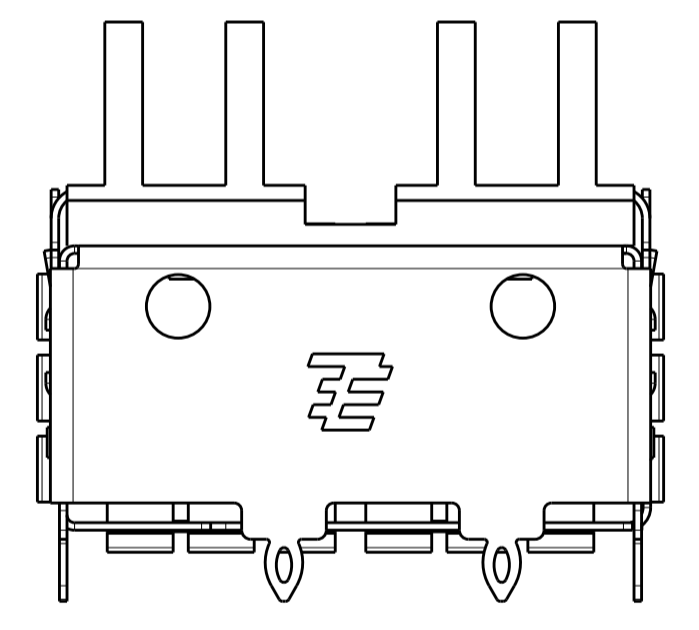
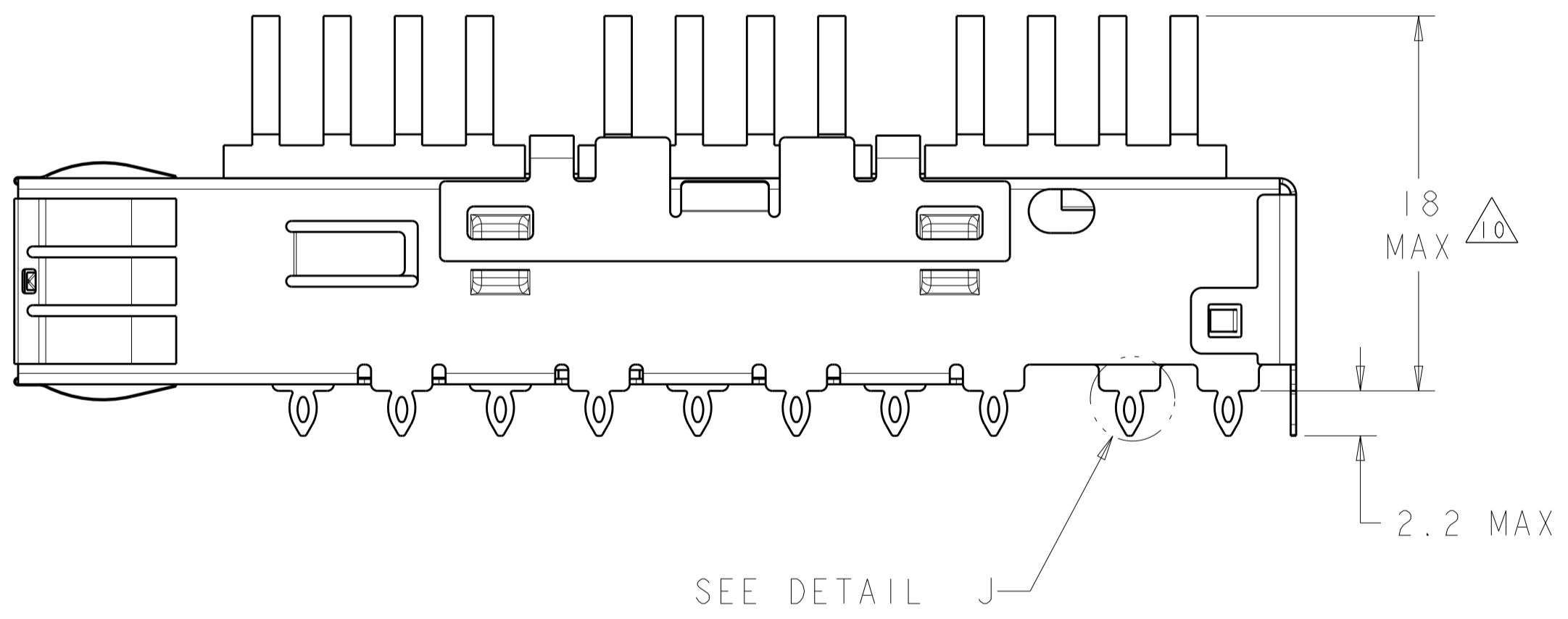
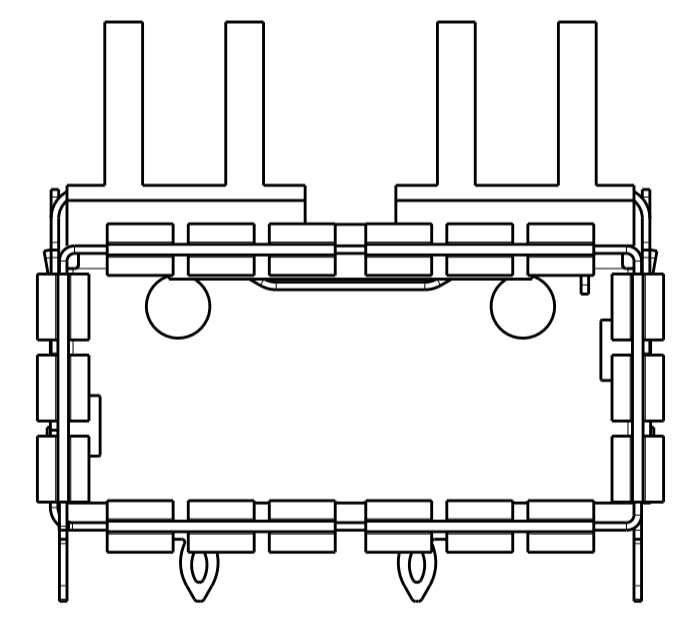

PART NUMBER
2170450-1

THIS PRINT IS
PRELIMINARY
UNQUALIFIED PRODUCT
CONTACT PRODUCT ENGINEERING
BEFORE USING THIS PRINT

THIS DRAWING IS A CONTROLLED DOCUMENT.		DWN: D. ZHU CHK: J. YANG APVD: A. GAI	19SEP2012 19SEP2012 19SEP2012		TE Connectivity
DIMENSIONS:	TOLERANCES UNLESS OTHERWISE SPECIFIED:	PRODUCT SPEC	NAME		CAGE ASSEMBLY, THRU BEZEL, QSFP WITH HEAT SINK
mm	0 PLC ±0.25 2 PLC ±0.13 3 PLC ± 4 PLC ± ANGLES ±	108-2286	APPLICATION SPEC	114-13217	RESTRICTED TO
MATERIAL:	FINISH:	WEIGHT	SIZE	CAGE CODE	DRAWING NO
			A1	00779	C=2170450
Customer Drawing		SCALE	2:1	SHEET	1 of 4

LOC	DIST	REVISIONS			
P	LTN	DESCRIPTION	DATE	DWN	APVD
GP	00	SEE SHEET 1			

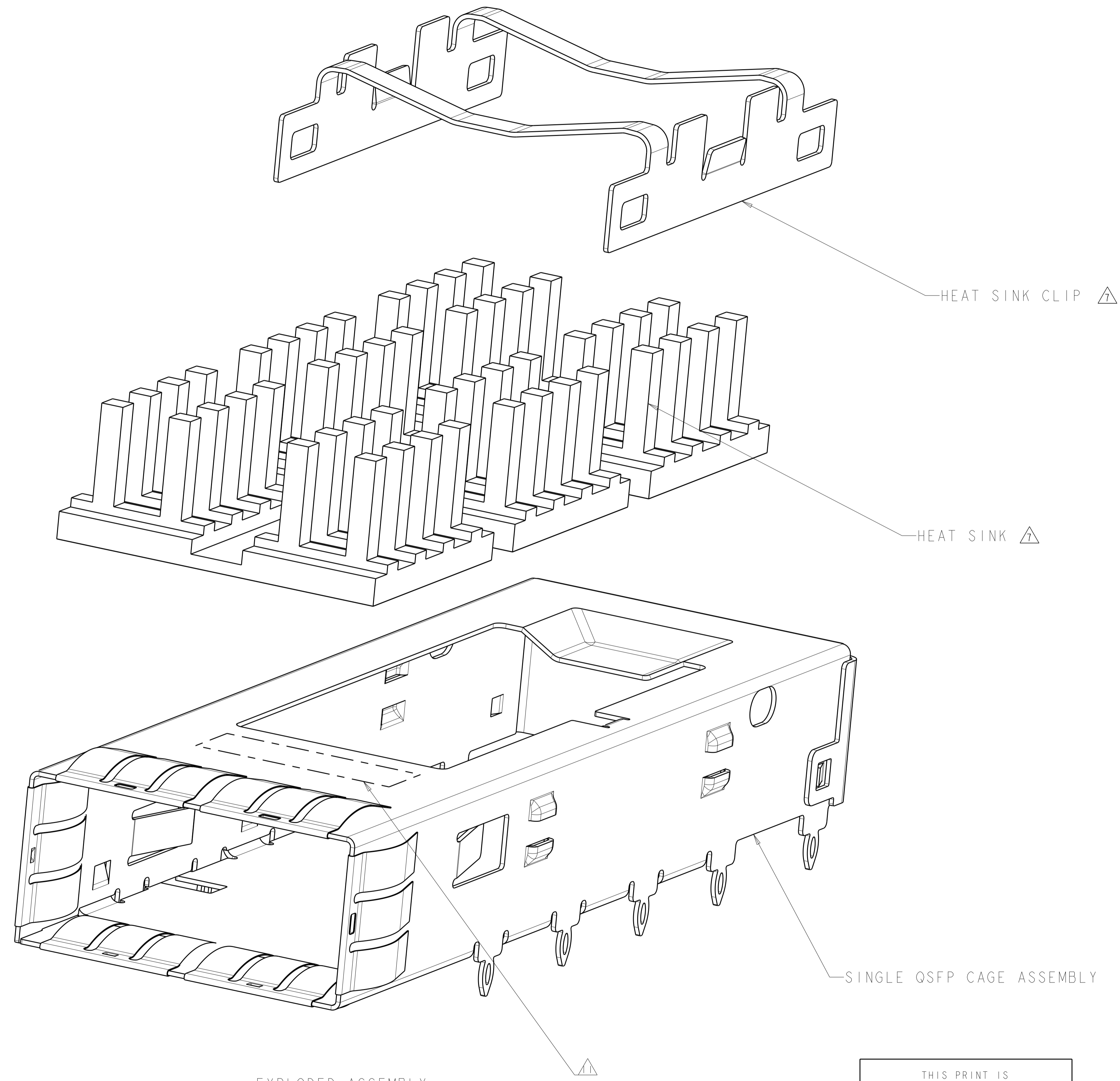

EXPLODED ASSEMBLY
 SCALE 8:1

THIS PRINT IS
PRELIMINARY
 UNQUALIFIED PRODUCT
 CONTACT PRODUCT ENGINEERING
 BEFORE USING THIS PRINT

THIS DRAWING IS A CONTROLLED DOCUMENT.		DWN D. ZHU	19SEP2012	TE Connectivity NAME CAGE ASSEMBLY, THRU BEZEL , QSFP WITH HEAT SINK PRODUCT SPEC 108-2286 APPLICATION SPEC 114-13217 WEIGHT - Customer Drawing	RESTRICTED TO			
DIMENSIONS:		CHK J. YANG	19SEP2012		SIZE	CAGE CODE	DRAWING NO	
mm		APVD A. CAI	19SEP2012		A1	00779	C=2170450	
0 PLC ± 1 PLC ±0.25 2 PLC ±0.13 3 PLC ± 4 PLC ± ANGLES ± FINISH ±					SCALE	SHEET	OF	
				2:1	2	4	REV	1

LOC	DIST	REVISIONS			
P	LTN	DESCRIPTION	DATE	DMN	APVD
GP	00	SEE SHEET 1	-	-	-

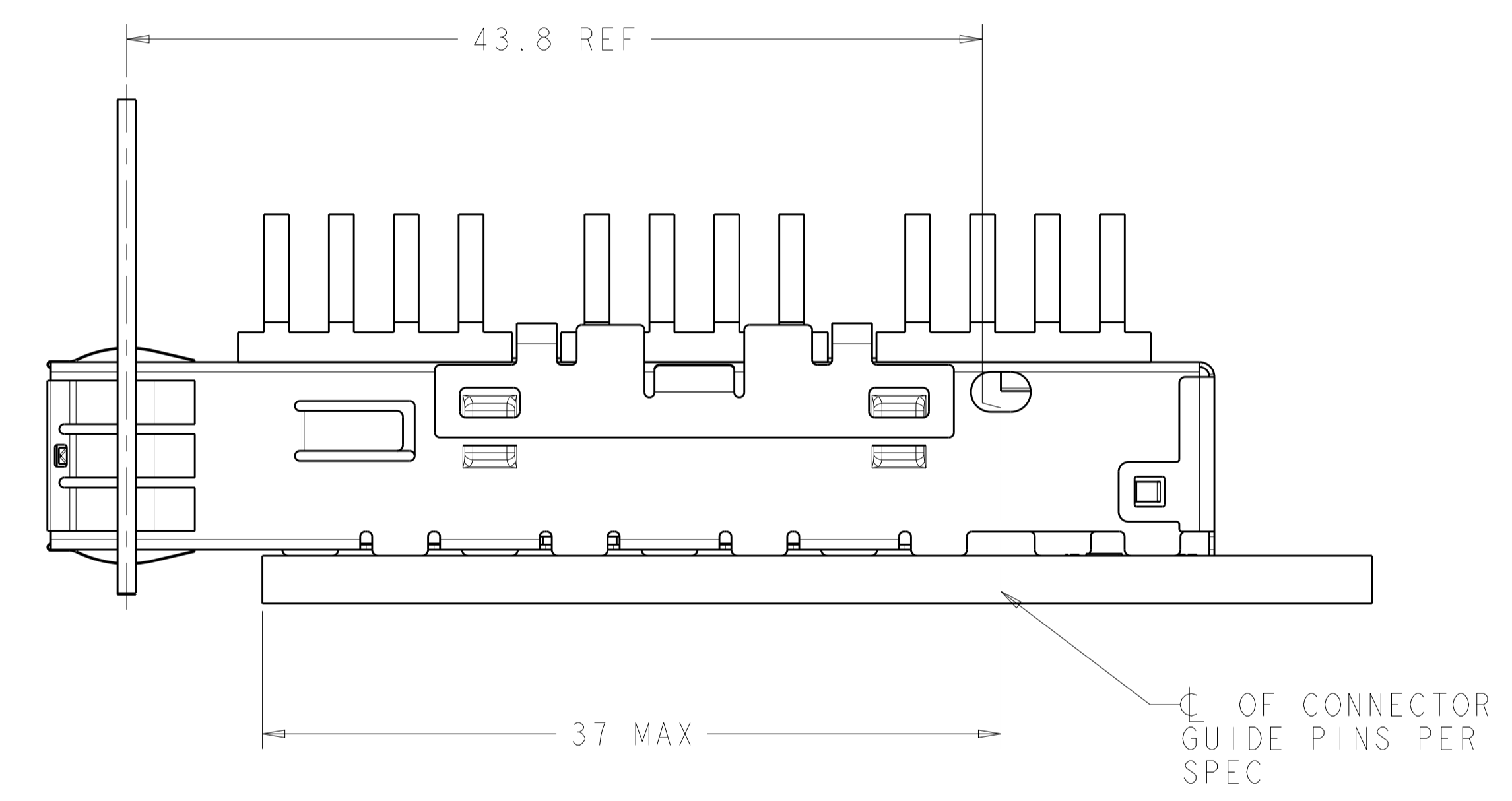
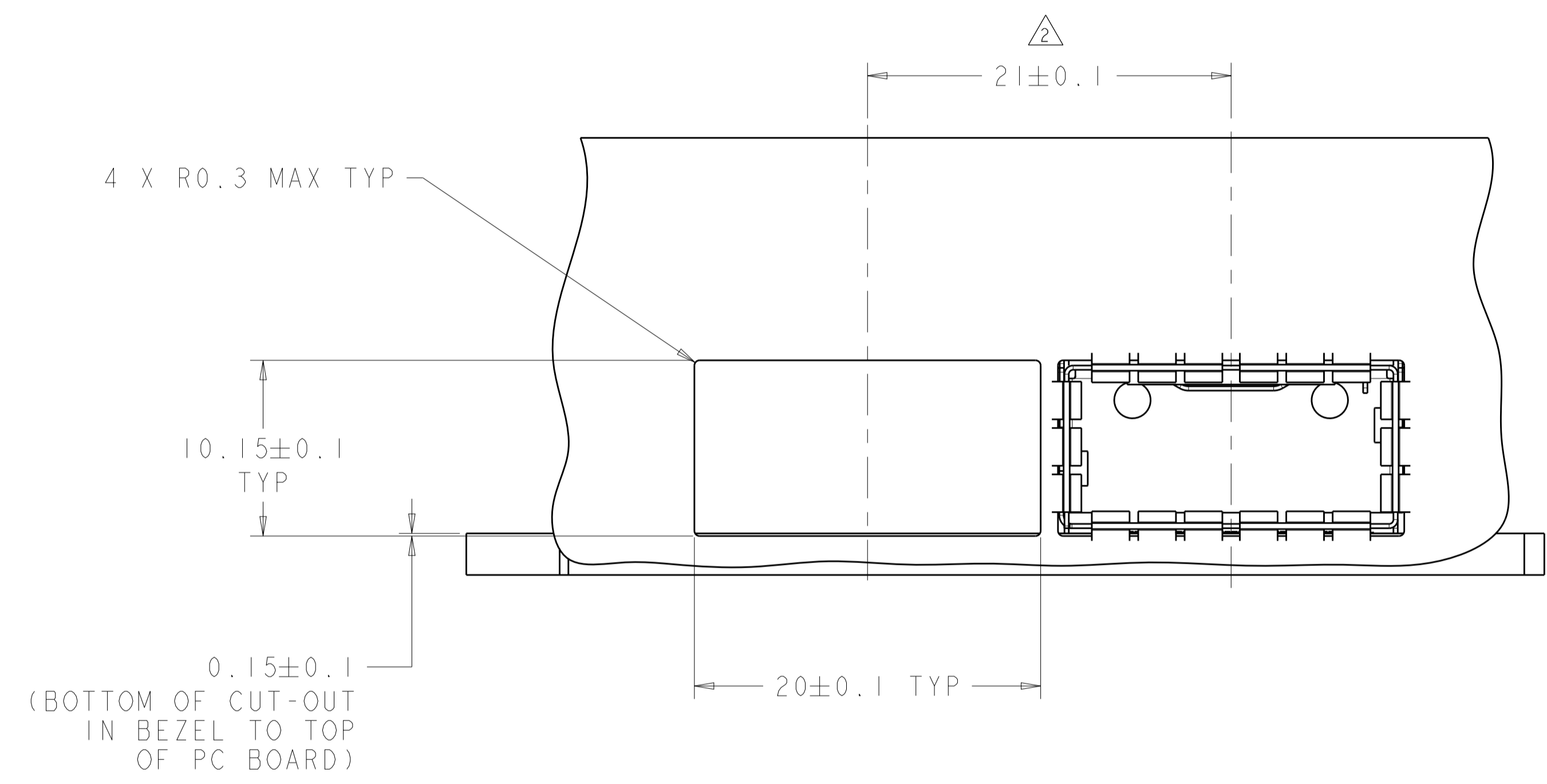

THIS PRINT IS
PRELIMINARY
 UNQUALIFIED PRODUCT
 CONTACT PRODUCT ENGINEERING
 BEFORE USING THIS PRINT

THIS DRAWING IS A CONTROLLED DOCUMENT.		DMN D. ZHU 19SEP2012	19SEP2012		NAME CAGE ASSEMBLY, THRU BEZEL, OSFP WITH HEAT SINK
DIMENSIONS:		CHK J. YANG 19SEP2012	19SEP2012		
TOLERANCES UNLESS OTHERWISE SPECIFIED:		APVD A. CAI 19SEP2012	19SEP2012		
mm		0 PLC ±	108-2286		
1 PLC ±0.25		2 PLC ±0.13	APPLICATION SPEC	SIZE	CAGE CODE
3 PLC ±		4 PLC ±	114-13217	A100779	C=2170450
ANGLES		FINISH	WEIGHT	Customer Drawing	SCALE
-		-	-	2:1	SHEET 3 OF 4
-		-	-	REV 1	

LOC		DIST		REVISIONS			
GP	00	P	LTN	DESCRIPTION	DATE	DWN	APVD
-	-	-	-	SEE SHEET 1	-	-	-

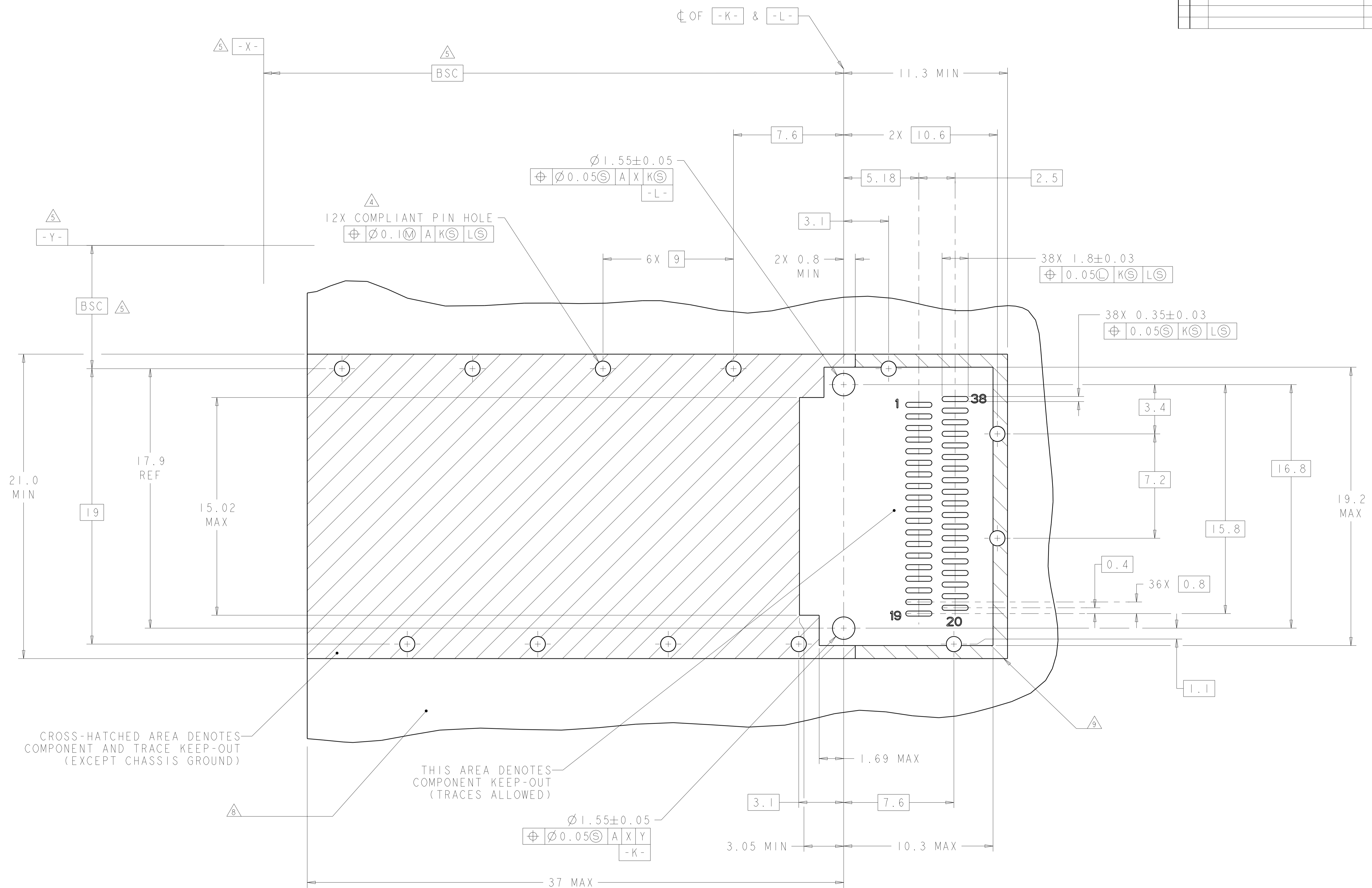

CROSS-HATCHED AREA DENOTES COMPONENT AND TRACE KEEP-OUT (EXCEPT CHASSIS GROUND)

THIS AREA DENOTES COMPONENT KEEP-OUT (TRACES ALLOWED)

RECOMMENDED PCB LAYOUT
 SCALE 8:1

THIS PRINT IS
PRELIMINARY
 UNQUALIFIED PRODUCT
 CONTACT PRODUCT ENGINEERING
 BEFORE USING THIS PRINT

THIS DRAWING IS A CONTROLLED DOCUMENT.		DWN	D. ZHU	19SEP2012	TE Connectivity NAME CAGE ASSEMBLY, THRU BEZEL, QSPF WITH HEAT SINK PRODUCT SPEC 108-2286 APPLICATION SPEC 114-13217 WEIGHT Customer Drawing
DIMENSIONS:		CHK	J. YANG	19SEP2012	
mm		APVD	A. CAI	19SEP2012	
0 PLC ± 1 PLC ±0.25 2 PLC ±0.13 3 PLC ± 4 PLC ± ANGLES ±		TOLERANCES UNLESS OTHERWISE SPECIFIED: FINISH		SIZE A1 CAGE CODE 00779 DRAWING NO C=2170450	
MATERIAL		RESTRICTED TO		SCALE	2:1
		SHEET		4	OF
		REV		4	