

4

3

2

1

THIS DRAWING IS UNPUBLISHED.

RELEASED FOR PUBLICATION

20

© COPYRIGHT 20

ALL RIGHTS RESERVED.

LOC  
ES

DIST

REVISIONS

P	LTR	DESCRIPTION	DATE	DWN	APVD
	A	INITIAL	13NOV2013	R.W	W.H
	A2	REVISED PER ECR-18-010822	10JUL2018	E.Z	W.H

PART NUMBER:2199170-1

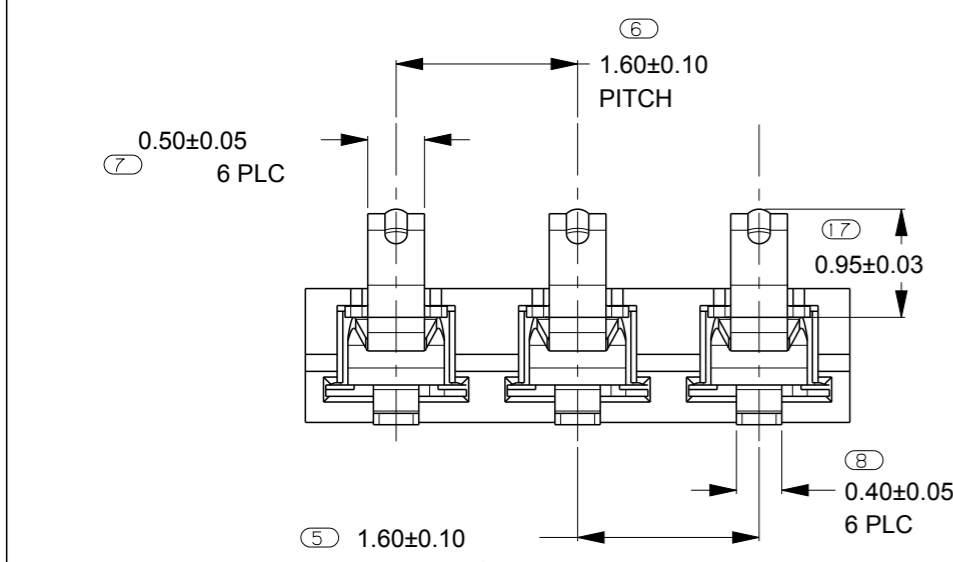
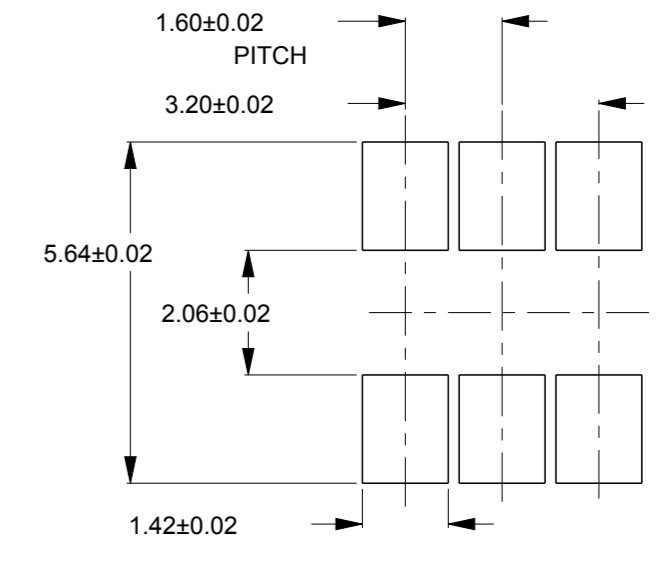
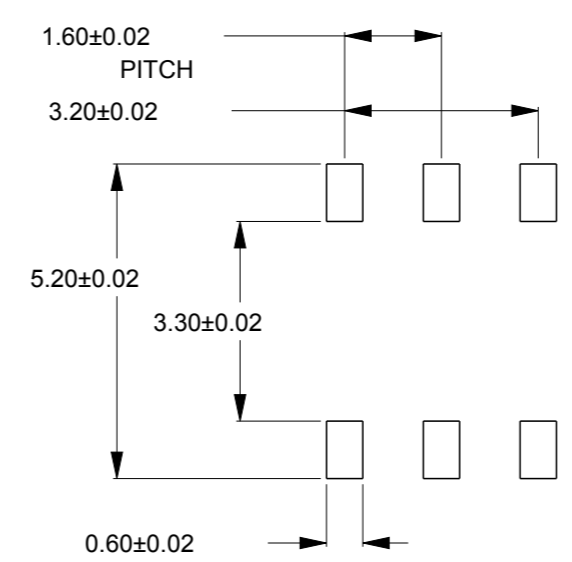
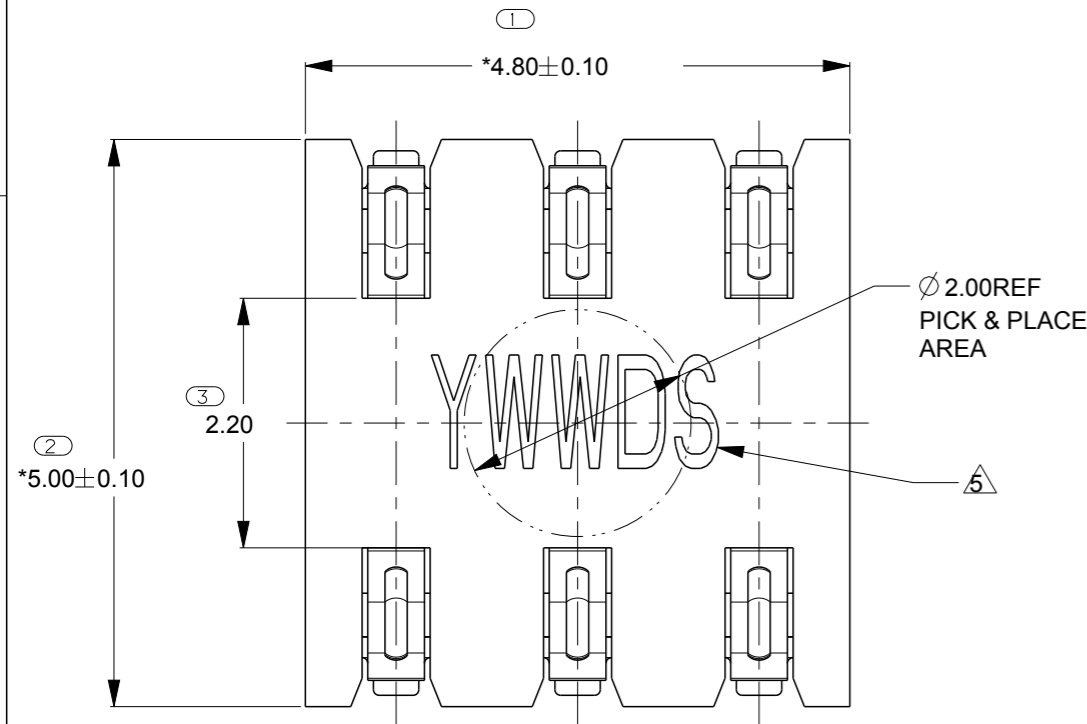

NORMAL FORCE CURVE

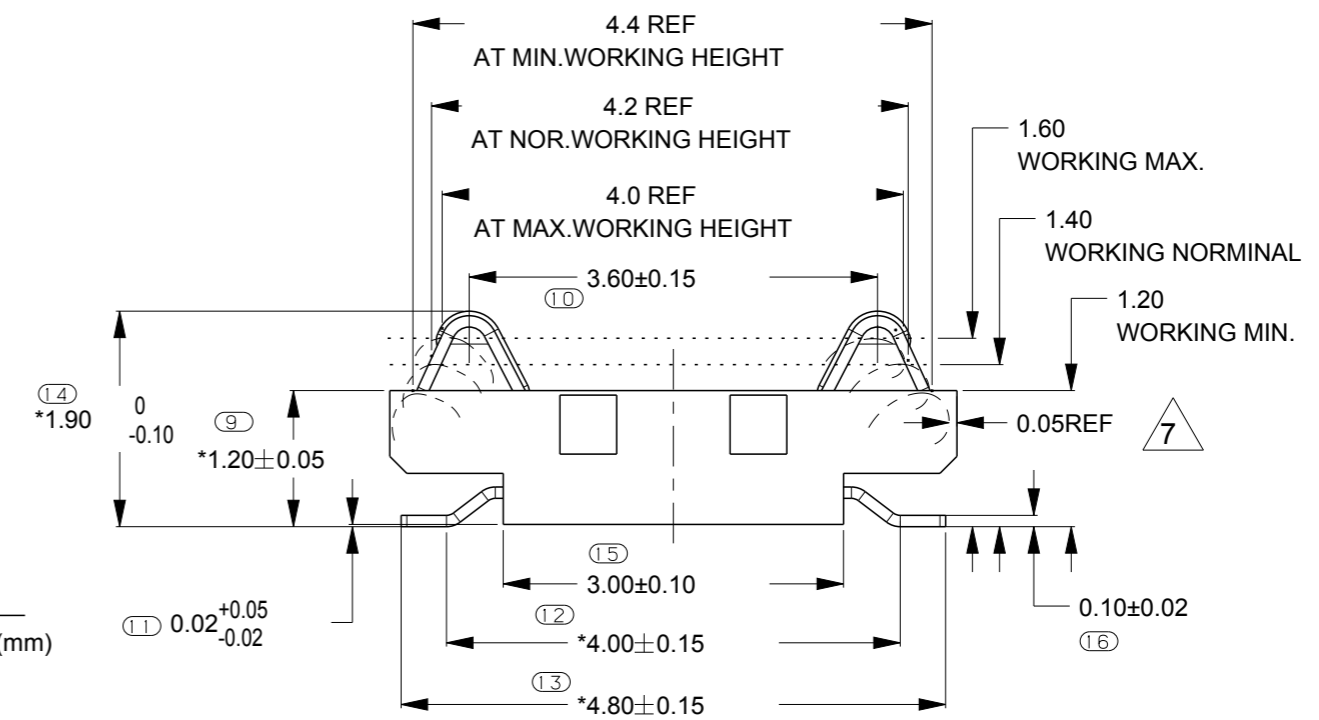
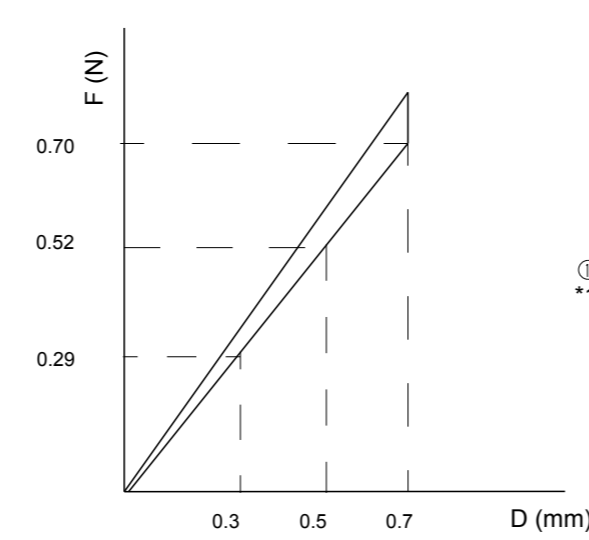

- NOTES:
- MATERIAL: PHOSPHOR BRONZE C5210HF, THICKNESS 0.10mm.
  - TERMINAL: HIGH TEMPERATURE THERMO PLASTIC UL94V-0 BLACK
  - FINISH: TERMINAL: 0.1-0.2  $\mu$ m GOLD PLATING ON CONTACT AREA, 1.27 MIN. NICKLE UNDER PLATING, 0.025-0.075  $\mu$ m GOLD PLATING ON SOLDERING AREA.
  - COPLANARITY: BEFORE REFLOW 0.08 MAX, AFTER REFLOW 0.1 MAX
  - PACKAGING: TAPE & REEL.
  - DATE CODE: "YWWDS"
  - YWW = PRODUCTION DATE (YEAR, WEEK, DAY).
  - S = SHIFT (D=DYA, N=NIGHT)
  - CONTACT CAN NOT TOUCH PCB & TAIL WHEN PRESS TO HOUSING SURFACE.
  - CONTACT CAN NOT EXCEED HOUSING EDGE WHEN PRESS TO HOUSING SURFACE
  - \* MEANS KEY DIMENSIONS FOR CUSTOMER

THIS DRAWING IS A CONTROLLED DOCUMENT.		DWN	13NOV2013	 TE Connectivity	NAME <b>ONE PIECE BtoB CONNECTOR</b> <b>6 PINS, 1.6MM PITCH, H1.4, TWO ROWS</b>
DIMENSIONS: mm		CHK	13NOV2013		
TOLERANCES UNLESS OTHERWISE SPECIFIED: $\pm 0.15$		APVD	13NOV2013		
$\varnothing$ PLC $\pm$ 1-PLC $\pm$ 2-PLC $\pm$ 3-PLC $\pm$ 4-PLC $\pm$ ANGLES $\pm 3^\circ$		PRODUCT SPEC	-	SIZE	A3
MATERIAL		FINISH	-	APPLICATION SPEC	-
		WEIGHT	-	RESTRICTED TO	-
		CUSTOMER DRAWING		SCALE	20:1
				SHEET	1 OF 2
				REV	A2

THIS DRAWING IS UNPUBLISHED. RELEASED FOR PUBLICATION 20  
 © COPYRIGHT 20 ALL RIGHTS RESERVED.

LOC	DIST	REVISIONS			
P	LTR	DESCRIPTION	DATE	DWN	APVD
ES		SEE SHEET 1			

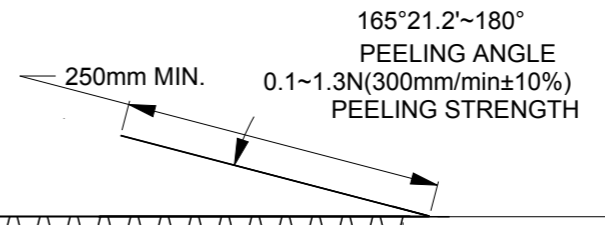
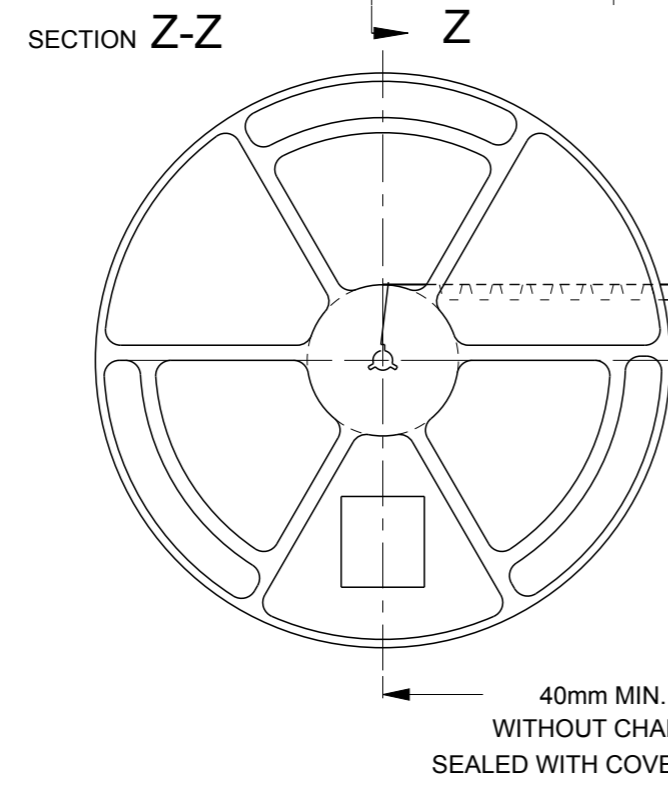
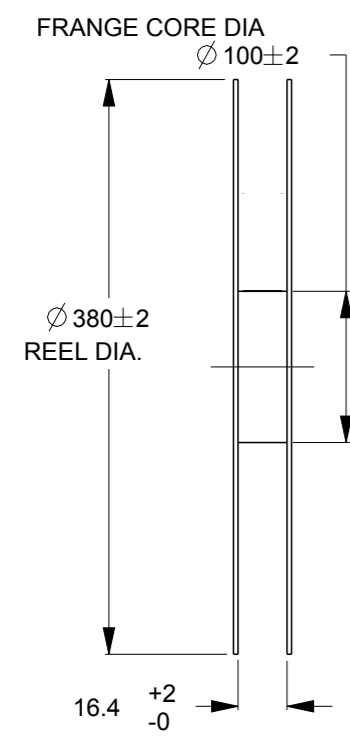
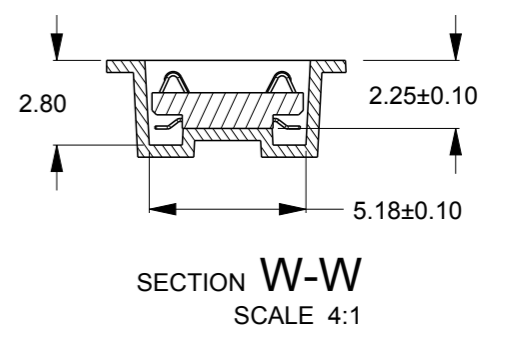
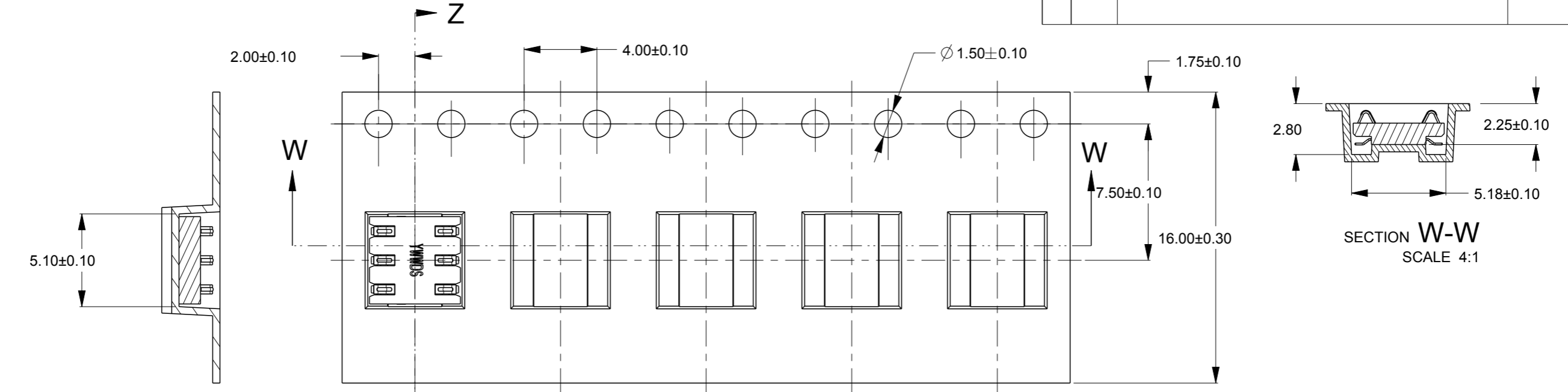

250mm MIN.  
 WITH PRODUCT CHARGE 3500 PCS/1REEL  
 100mm MIN. WITHOUT CHARGE SEALED WITH COVER TAPE

NOTES:  
 1. MATERIAL: P.S CLEAR, 0.4MM THICKNESS.  
 2. QUANTITY PER REEL: 3500 PIECES.

THIS DRAWING IS A CONTROLLED DOCUMENT.		DWN	RAY WANG	13NOV2013	 TE Connectivity			
DIMENSIONS: mm		CHK	WENKE HE	13NOV2013				
TOLERANCES UNLESS OTHERWISE SPECIFIED: ± 0.20		APVD	WENKE HE	13NOV2013				
0.PLC ± 1.PLC ± 2.PLC ± 3.PLC ± 4.PLC ± ANGLES ±3°		PRODUCT SPEC	NAME					
MATERIAL	FINISH	WEIGHT	ONE PIECE BtoB CONNECTOR 6 PINS, 1.6MM PITCH, H1.4, TWO ROWS		RESTRICTED TO			
1	2	-	SIZE	A3	CAGE CODE	00779	DRAWING NO	C-2199170
CUSTOMER DRAWING			SCALE	20:1	SHEET	2 OF 2	REV	A2