

THIS DRAWING IS UNPUBLISHED. RELEASED FOR PUBLICATION 20  
 © COPYRIGHT 20 BY - ALL RIGHTS RESERVED.

REVISIONS					
P	LTR	DESCRIPTION	DATE	DWN	APVD
A		REVISED AS PER ECR-15-005925	21APR2015	RS	JL
A1		ECR-18-006945	05JUL2018	SR	MZ

NOTES:

1. MATERIAL: GLASS FILLED PBT, COLOR: BLACK
2. MUST COMPLY WITH DIRECTIVE 2002/95/EC (ROHS)
3. ALL POLARIZATION KEYS SHOWN FOR REF ONLY.
4. CIRCUIT I.D.
5. TE PART NUMBER
6. TE LOGO
7. THIS PRODUCT HAS NOT COMPLETED VALIDATION TESTING

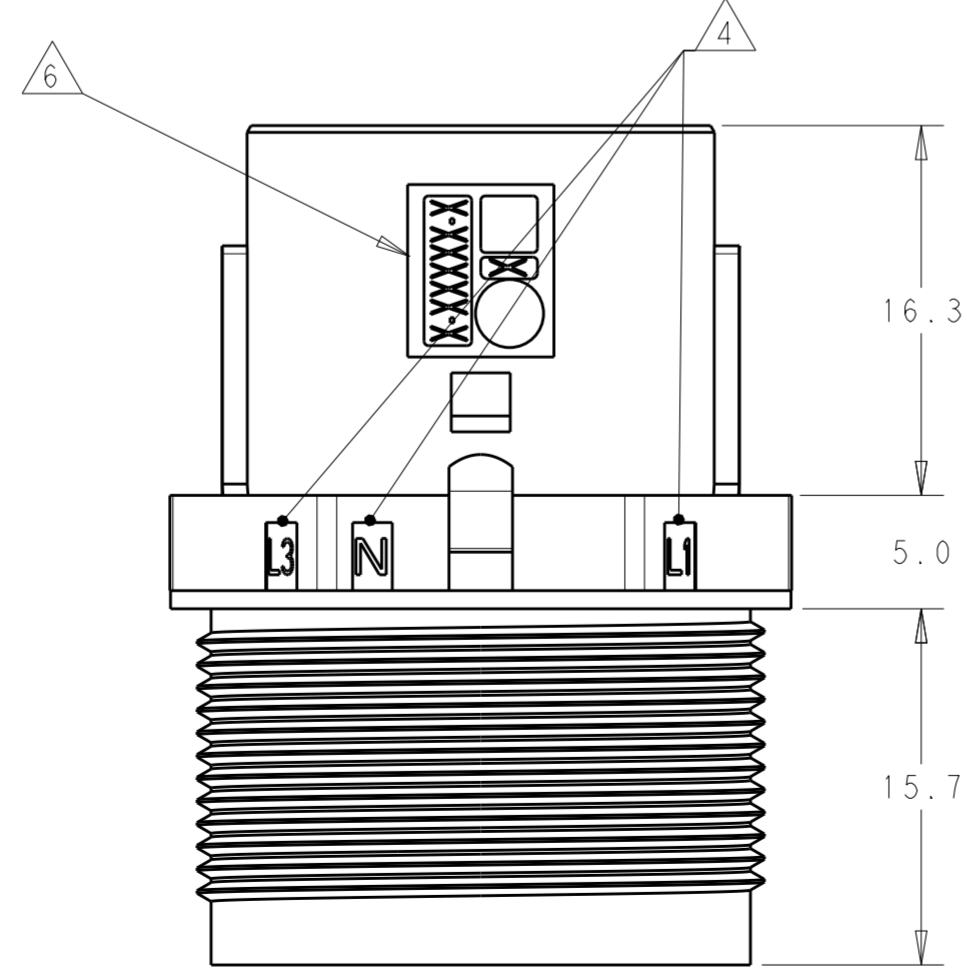
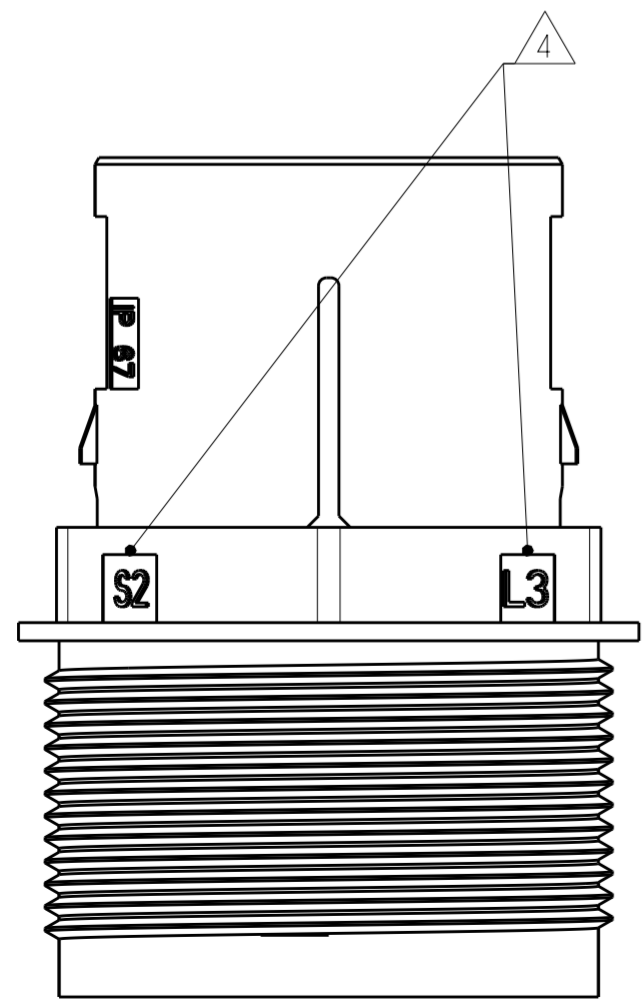
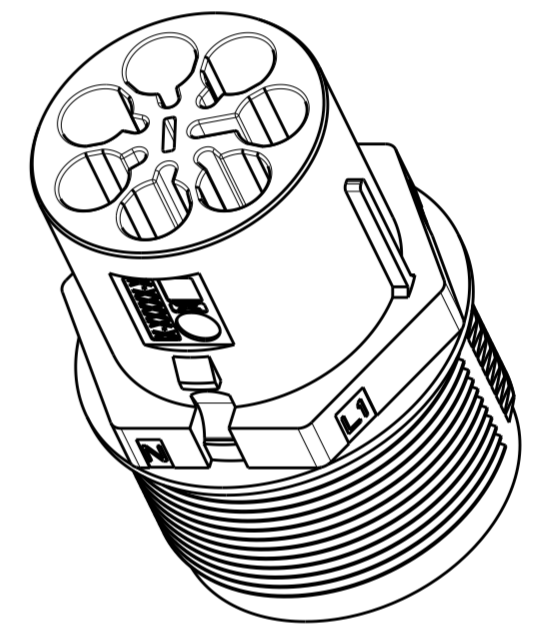
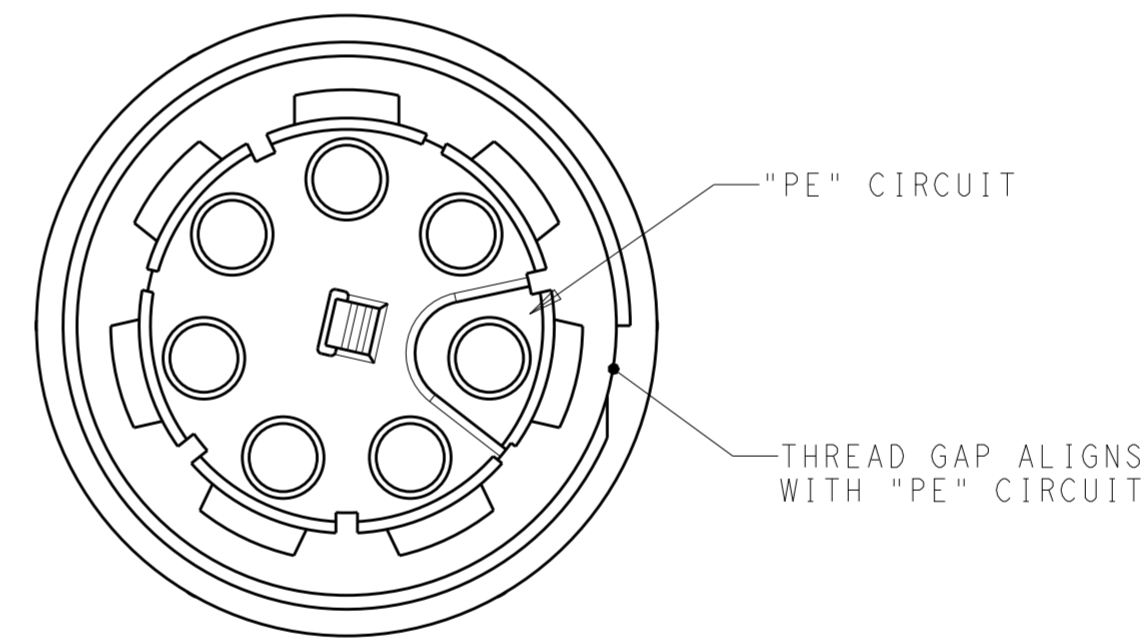
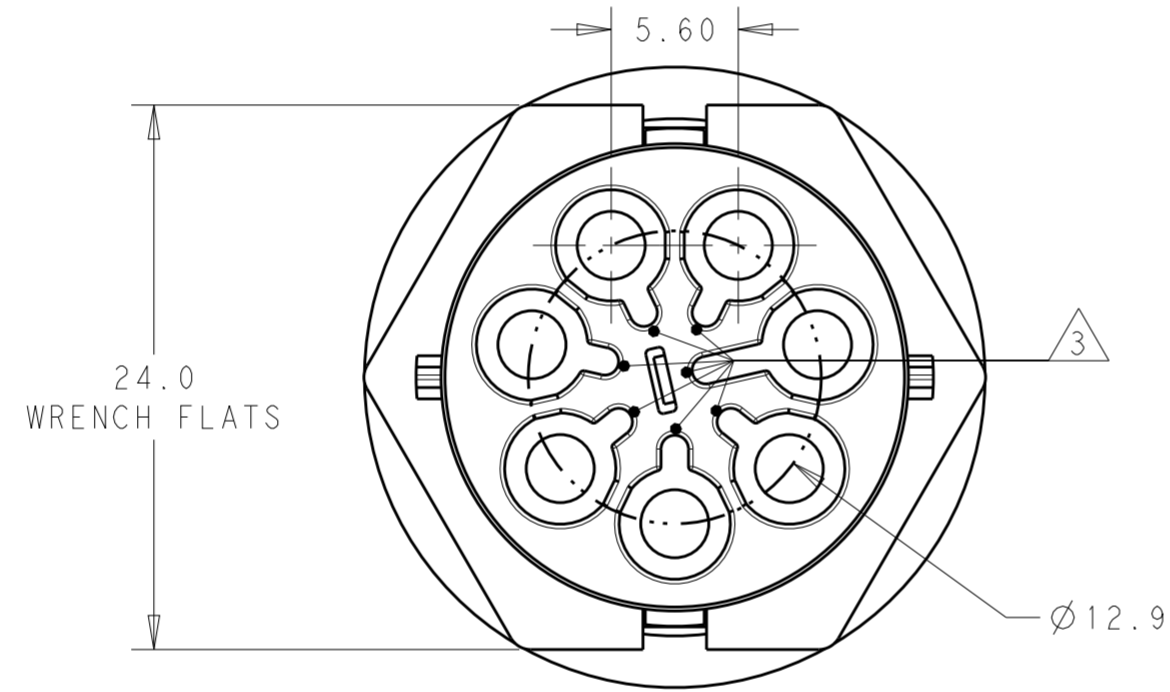
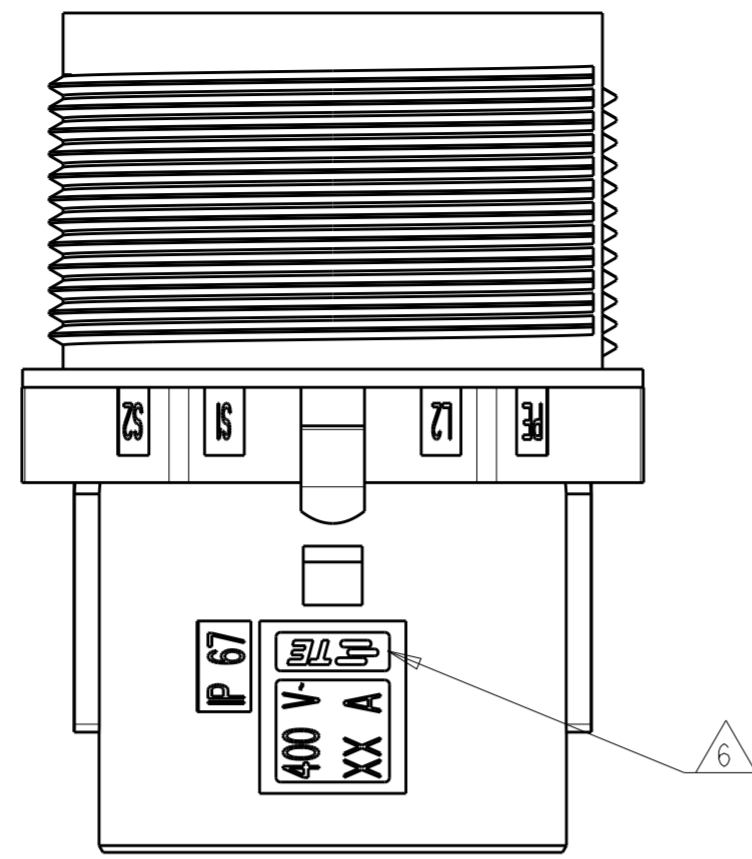



OBSOLETE	E	FREE HANGING PIN. SEALED NECTOR M, 7 POSN	2213242-5	
	D	FREE HANGING PIN. SEALED NECTOR M, 7 POSN	2213242-4	
	C	FREE HANGING PIN. SEALED NECTOR M, 7 POSN	2213242-3	
	B	FREE HANGING PIN. SEALED NECTOR M, 7 POSN	2213242-2	
	A	FREE HANGING PIN. SEALED NECTOR M, 7 POSN	2213242-1	
	POLARIZATION KEYING		DESCRIPTION	PART NUMBER

THIS DRAWING IS A CONTROLLED DOCUMENT.		DWN J. SHAFFER 21 JAN 2014	TE Connectivity			
DIMENSIONS: mm		CHK M. LUKSIC 21 JAN 2014				
TOLERANCES UNLESS OTHERWISE SPECIFIED:		APVD M. LUKSIC 21 JAN 2014				
0 PLC ± 1 PLC ±0.2 2 PLC ±0.13 3 PLC ± 4 PLC ± ANGLES ± FINISH ±		PRODUCT SPEC 108-133014 APPLICATION SPEC 114-32111 WEIGHT - Customer Drawing				
NOTE 1		NAME	SIZE A2	CAGE CODE -	DRAWING NO. C-2213242	RESTRICTED TO -
			SCALE 2:1	SHEET 1 OF 2	REV A1	

THIS DRAWING IS UNPUBLISHED. RELEASED FOR PUBLICATION 20  
 © COPYRIGHT 20 BY - ALL RIGHTS RESERVED.

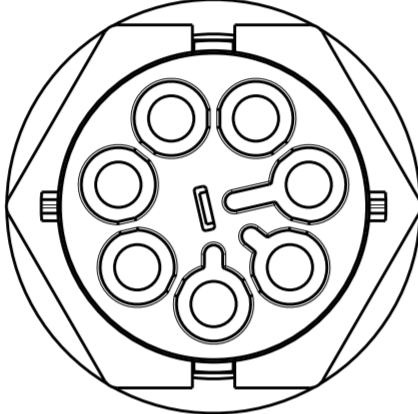
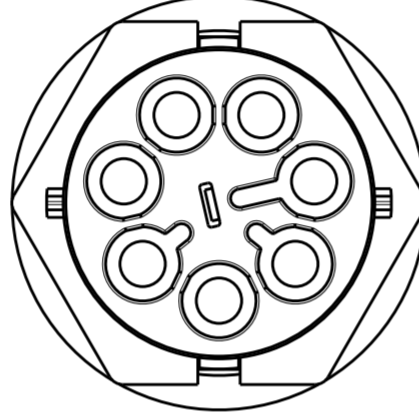
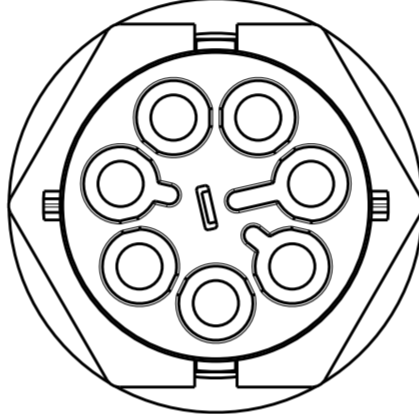
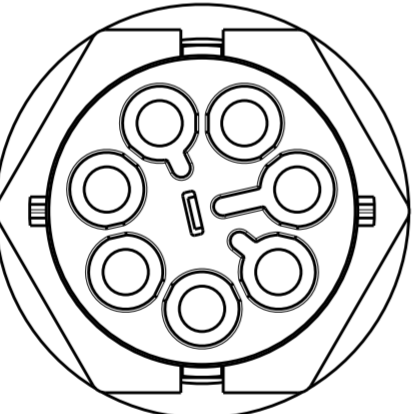
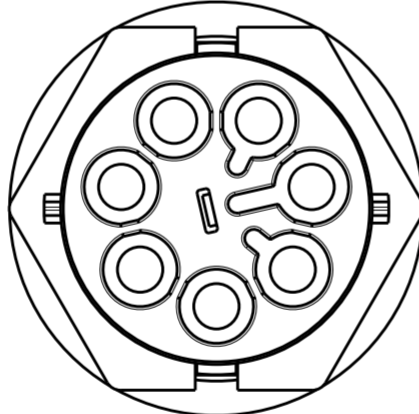
REVISIONS				
P	LTR	DESCRIPTION	DATE	APVD
-		SEE SHEET 1	-	-

POLARIZATION TYPES		
POLARIZATION TYPE "A"	POLARIZATION TYPE "B"	POLARIZATION TYPE "C"
		
PN: 2213242-1	<del>PN: 2213242-2</del>	<del>PN: 2213242-3</del>
POLARIZATION TYPE "D"	POLARIZATION TYPE "E"	
		
<del>PN: 2213242-4</del>	<del>PN: 2213242-5</del>	

THIS DRAWING IS A CONTROLLED DOCUMENT.		DWN J. SHAFFER 21 JAN 2014	 TE Connectivity	
DIMENSIONS: mm		CHK M. LUKSIC 21 JAN 2014		
TOLERANCES UNLESS OTHERWISE SPECIFIED:		APVD M. LUKSIC 21 JAN 2014	NAME FREE HANGING PIN HOUSING SEALED NECTOR M-LINE, 7 POSN	
0 PLC ± 1 PLC ±0.2 2 PLC ±0.13 3 PLC ± 4 PLC ±		PRODUCT SPEC 108-133014	RESTRICTED TO	
MATERIAL NOTE 1		APPLICATION SPEC 114-32111	SIZE A2	CAGE CODE -
FINISH -		WEIGHT -	DRAWING NO C-2213242	SCALE 2:1
		Customer Drawing	SHEET 2 OF 2	REV A1