

THIS DRAWING IS UNPUBLISHED. RELEASED FOR PUBLICATION 20
 © COPYRIGHT 2018 BY TE CONNECTIVITY ALL RIGHTS RESERVED.

REVISIONS				
P	LTR	DESCRIPTION	DATE	APVD
B		REVISED PER ECO-18-002521	19FEB2018	RS DH

- 1 CONTINUOUS STRIP ON REELS
- 2 WIRE SIZE: SINGLE 18-12, 2-18's OR 1-18/1-16
- 3 INSULATION RANGE IS 2.29-5.33 [.110-.210] DIA
- 4 MATING TAB THK IS 0.81±0.025 [.032±.001]
- 5 NOTE DELETED
- 6 NOTE DELETED
- 7 REELING ORIENTATION ACCORDING TO TE SPEC. 107-3 FIG. 243
- 8 THIS PART DASH # IS UL APPROVED FOR AWG 18-12

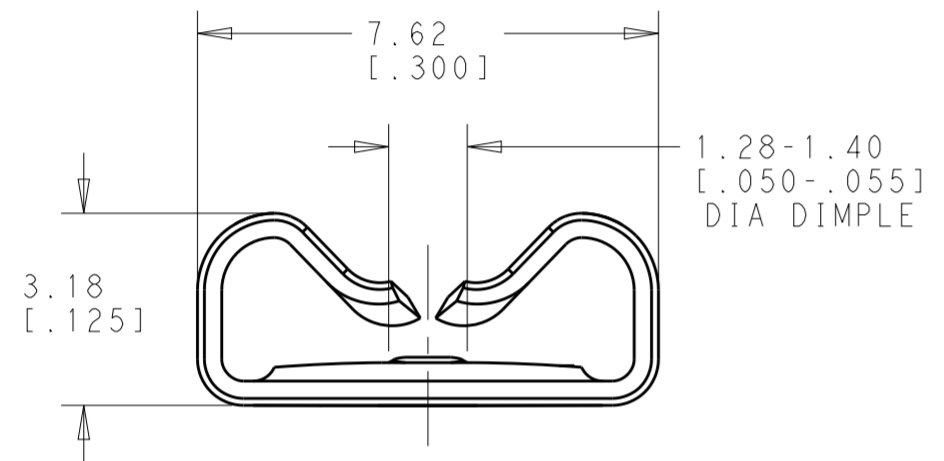

VIEW A-A
SCALE 8:1

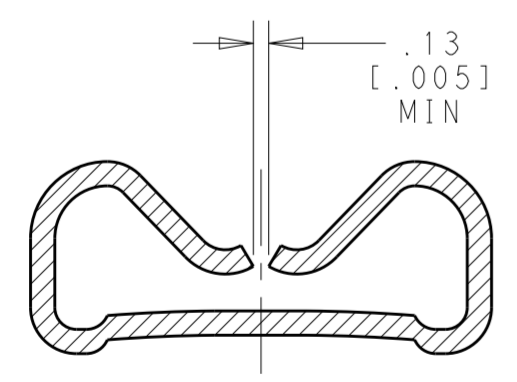
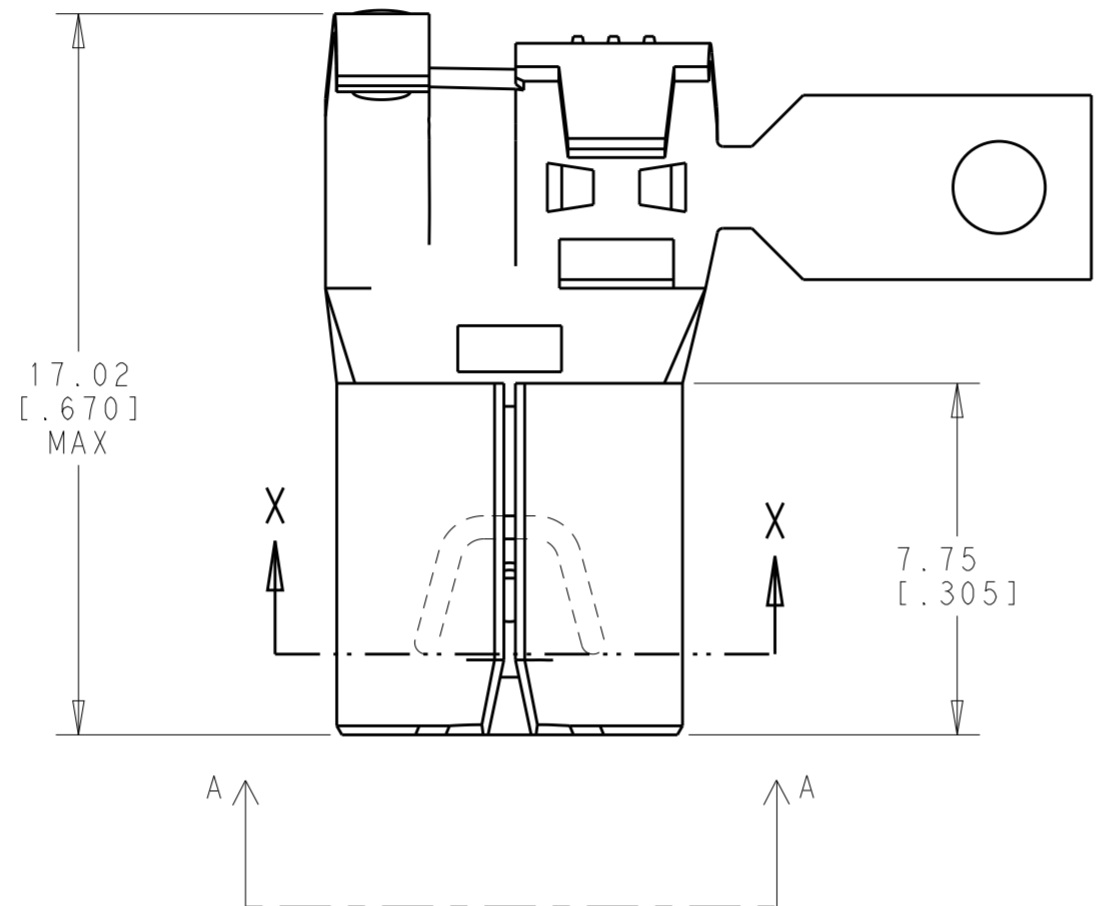

SECTION X-X
SCALE 8:1

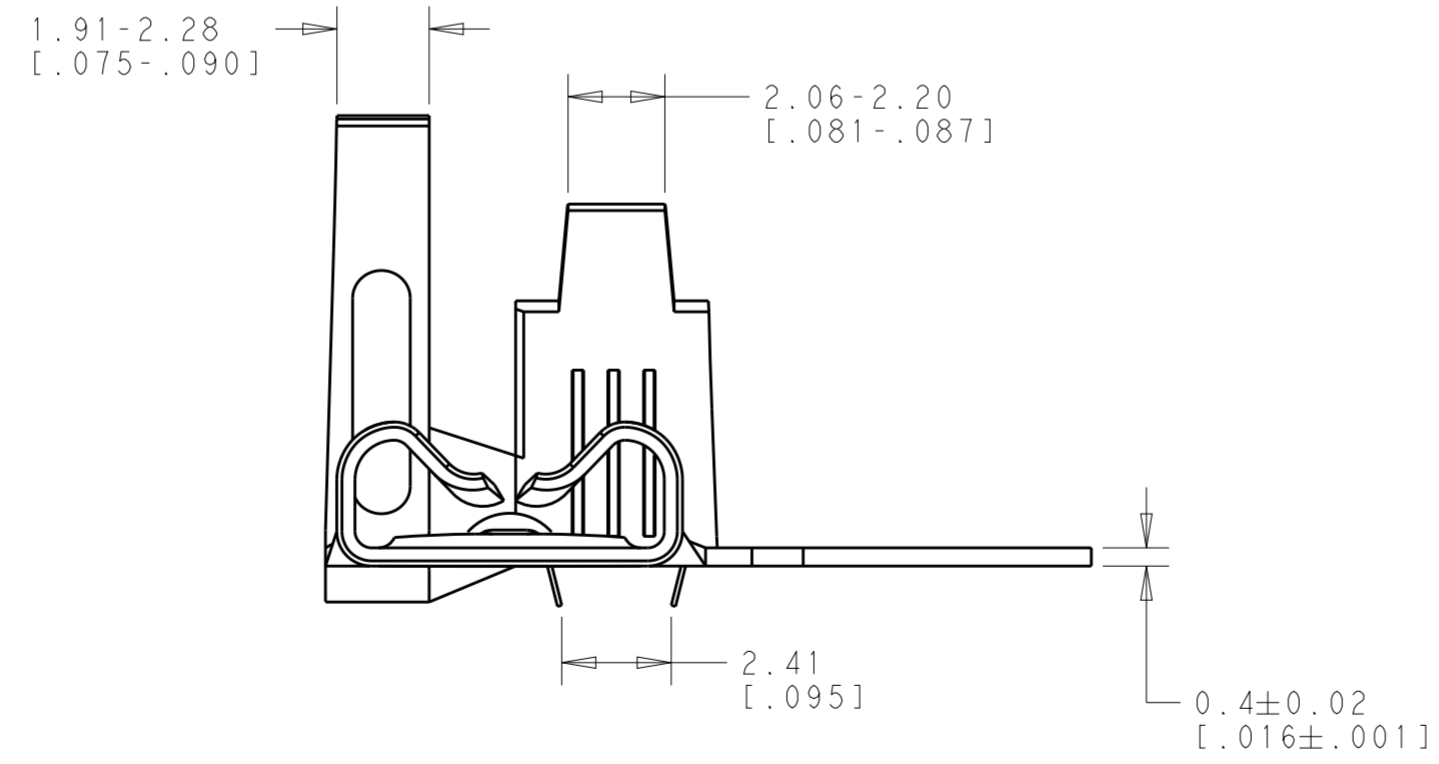

TIN	BRASS	2238197-3
FINISH	MATERIAL	PART NUMBER

THIS DRAWING IS A CONTROLLED DOCUMENT.		DWN 10 JAN 2018 BASVESH WARAD	TE Connectivity	
DIMENSIONS: mm [INCHES]		CHK 10 JAN 2018 HUMPHREY, DAVID		
TOLERANCES UNLESS OTHERWISE SPECIFIED:		APVD 10 JAN 2018 HUMPHREY, DAVID	NAME FASTON .250, STD REC RHFLAG TAB 18-12, TPBR	
0 PLC ±		PRODUCT SPEC -	SIZE CAGE CODE DRAWING NO RESTRICTED TO	
1 PLC ±		APPLICATION SPEC -	A200779 C-2238197	
2 PLC ±		WEIGHT -	SCALE 6:1 SHEET 1 OF 1 REV B	
3 PLC ±.010		CUSTOMER DRAWING		
4 PLC ±				
ANGLES ±5°				
FINISH SEE TABLE				