

THIS DRAWING IS UNPUBLISHED. RELEASED FOR PUBLICATION 20
 © COPYRIGHT 20 BY - ALL RIGHTS RESERVED.

REVISIONS					
P	LTR	DESCRIPTION	DATE	DWN	APVD
A		RELEASED FOR MASS PRODUCTION	23APR2019	TX	SH
A1		REVISED PER ECO-20-001509	20DEC2019	JY/IT	SH

- 1. MATERIAL :CAGE :0.4MM THICK NICKEL SILVER ALLOY;
EMI SPRING: COPPER ALLOY;
HEAT SINK CLIP: STAINLESS STEEL;
HEAT SINK:ALUMINUM ALLOY;
RECEPTACLE COVER:ZINC ALLOY;
- 2. FINISH: EMI SPRING :1.27um NICKEL PALTING OVER ALL;
HEAT SINK:BLACK ANODIZED COATING;
RECEPTACLE COVER: 1.27um MIN NICKEL PLATING OVER COPPER PLATING;
HEAT SINK CLIP:PASSIVATE;
- 3.MATES WITH CFP MSA COMPLIANT TRANSCEIVERS.
- 4.DATUM AND BASIC DIMENSION ESTABLISHED BY CUSTOMER.
- 5.MINIMUM PC BOARD THICKNESS: SIGLE SIDE APPLICATIONS 2.0MM MIN.
BELLY TO BELLY APPLICATION:3.0MM MIN
- 6.PADS AND VIAS CHASSIS GROUND;
- 7:REFERENCE APPLICATION SOEC 114-32146 FOR
RECOMMENDED DRILL HOLE DIAMETER AND PLATING THICKNESS.
- 8 DATE CODE LOCATED AT APPROXIMATE AREA AS SHOWN.

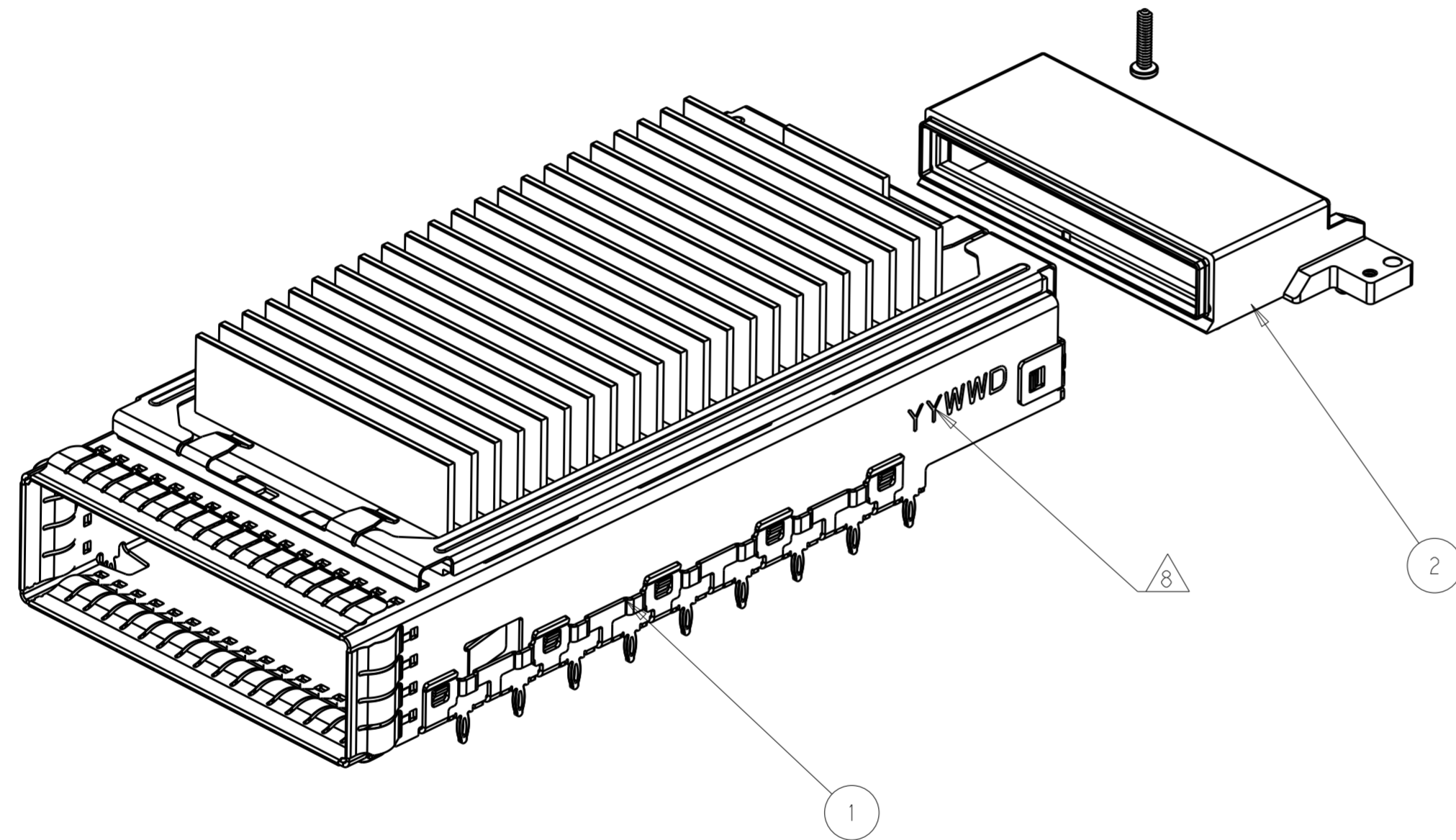

2	2	2	2	2	2	2292789-1	SCREW	3
1	1	1	1	1	1	2274846-1	RECEPTACLE COVER ASSEMBLY	2
1	-	-	-	-	-	2293277-9	CAGE ASSEMBLY WITH H/S,CFP2 1X1	1
-	1	-	-	-	-	2293277-8	CAGE ASSEMBLY WITH H/S,CFP2 1X1	
-	-	1	-	-	-	2293277-7	CAGE ASSEMBLY WITH H/S,CFP2 1X1	
-	-	-	1	-	-	2293277-6	CAGE ASSEMBLY WITH H/S,CFP2 1X1	
-	-	-	-	1	-	2293277-2	CAGE ASSEMBLY WITH H/S,CFP2 1X1	
-	-	-	-	-	1	2293277-1	CAGE ASSEMBLY WITH H/S,CFP2 1X1	
-6	-5	-4	-3	-2	-1	PAR NUMBER	DESCRIPTION	ITEM

THIS DRAWING IS A CONTROLLED DOCUMENT.

DWN ANDY.XIE 17JUN2015	TE Connectivity
CHK -	
APVD SEAN.HAN 17JUN2015	NAME HARD WARE KIT FOR CFP2 1X1 PRESS FIT (CAGE, HS, HS CLIP, COVER, SCREW)
PRODUCT SPEC 108-32103	SIZE A2
APPLICATION SPEC 114-32146	CAGE CODE -
WEIGHT -	DRAWING NO C-2274842
MATERIAL SEE NOTES	RESTRICTED TO -
FINISH SEE NOTES	SCALE 1:1
	SHEET 1 OF 9
	REV A1

CUSTOMER DRAWING

THIS DRAWING IS UNPUBLISHED. RELEASED FOR PUBLICATION 20
 © COPYRIGHT 20 BY - ALL RIGHTS RESERVED.

REVISIONS				
P	LTR	DESCRIPTION	DATE	APVD
-		SEE SHEET 1	-	-

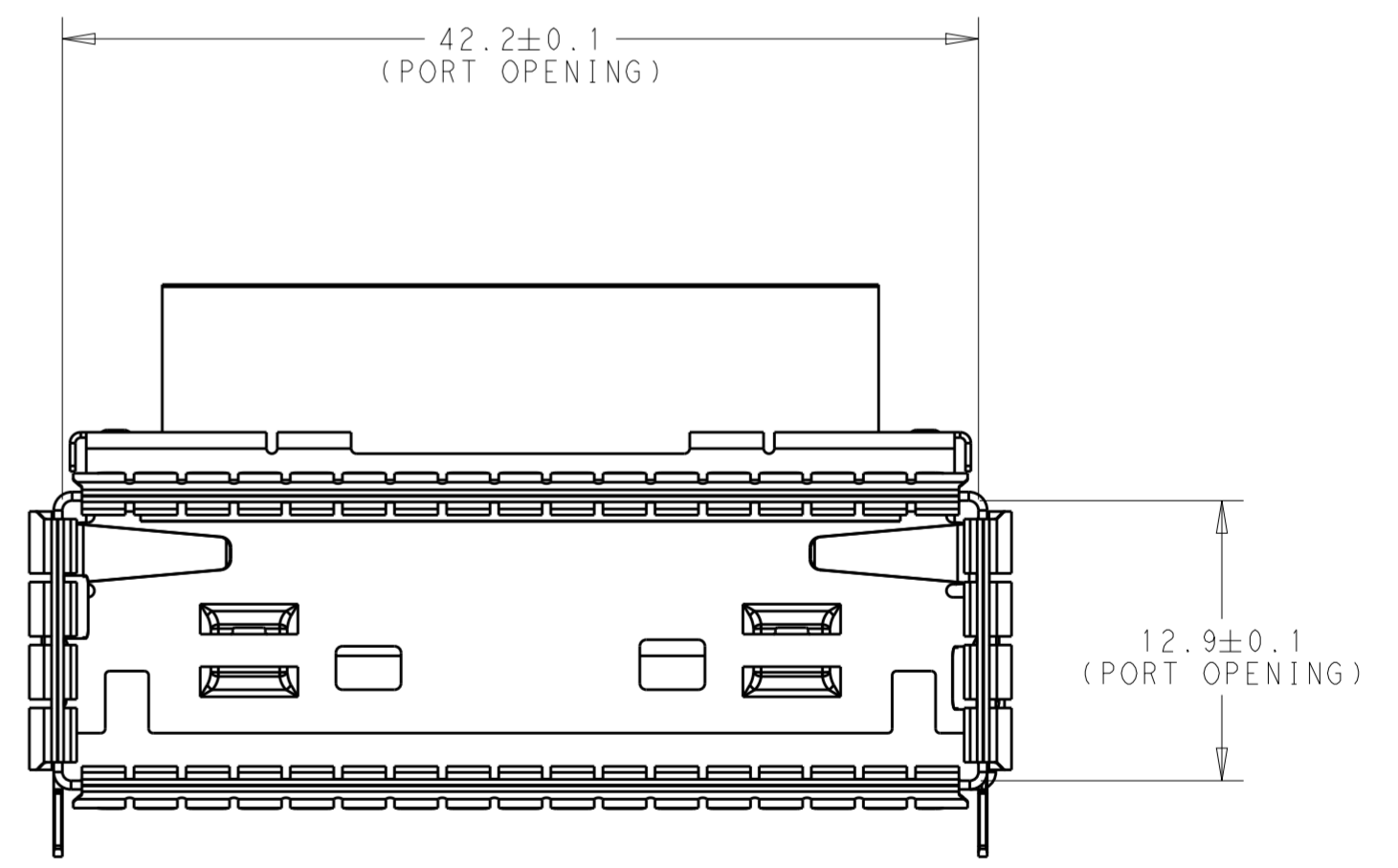
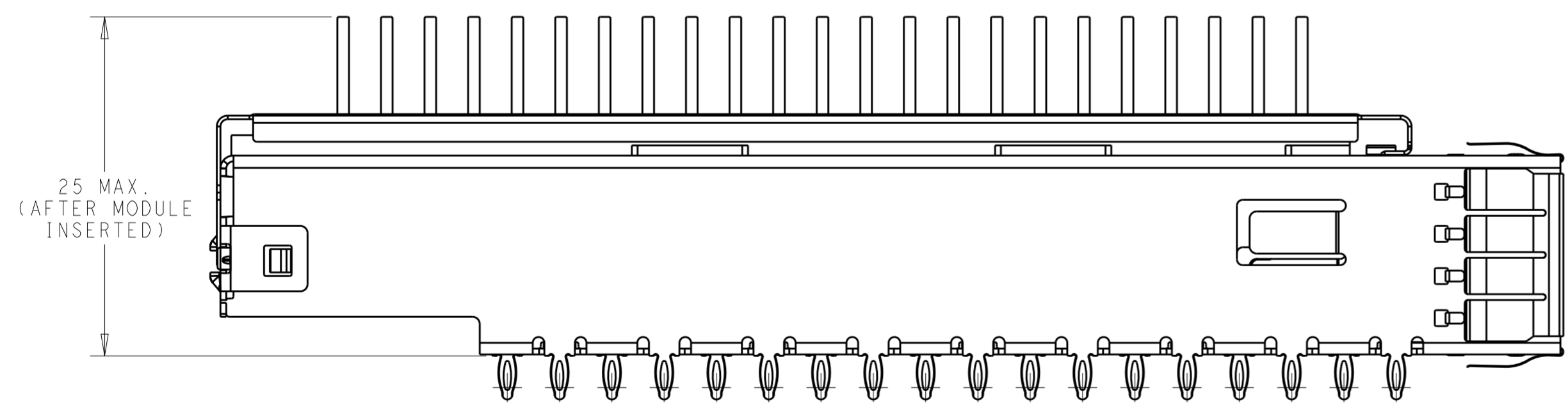
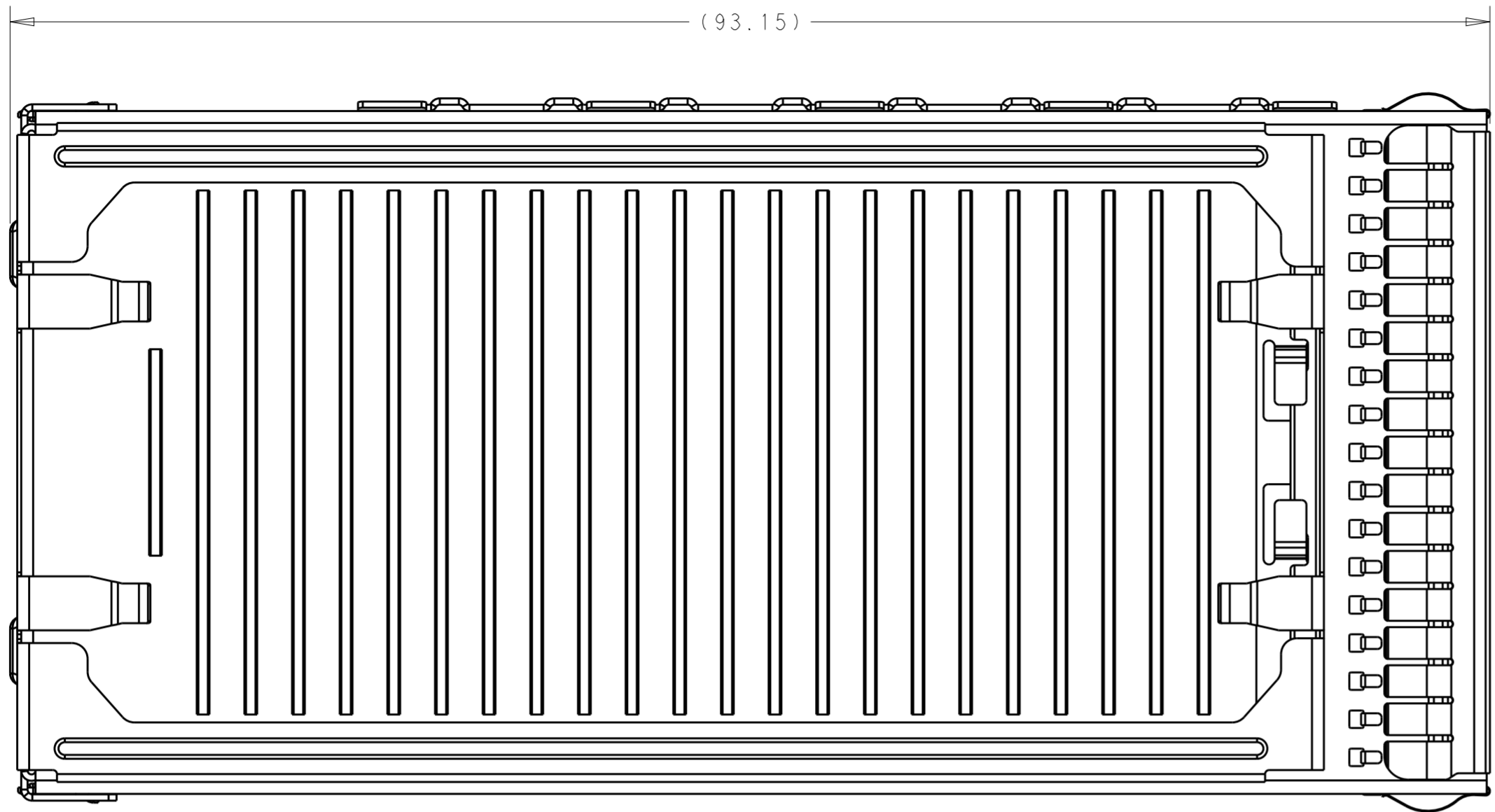

2293277-1 AS SHOWN

THIS DRAWING IS A CONTROLLED DOCUMENT.		DWN ANDY.XIE 17JUN2015	 TE Connectivity		
DIMENSIONS: mm		CHK -			
TOLERANCES UNLESS OTHERWISE SPECIFIED: 0 PLC ± 1 PLC ±0.25 2 PLC ±0.20 3 PLC ±0.1 4 PLC ±0.05 ANGLES ±1 FINISH		APVD SEAN.HAN 17JUN2015	NAME HARD WARE KIT FOR CFP2 1X1 PRESS FIT (CAGE, HS, HS CLIP, COVER, SCREW)		
MATERIAL SEE NOTES		PRODUCT SPEC 108-32103	SIZE A2	CAGE CODE -	DRAWING NO. C-2274842
FINISH SEE NOTES		APPLICATION SPEC 114-32146	RESTRICTED TO -	SCALE 1:1	SHEET 2 OF 9
		WEIGHT -	CUSTOMER DRAWING	REV A1	

THIS DRAWING IS UNPUBLISHED. RELEASED FOR PUBLICATION 20
 © COPYRIGHT 20 BY - ALL RIGHTS RESERVED.

REVISIONS				
P	LTR	DESCRIPTION	DATE	APVD
-	-	SEE SHEET 1	-	-

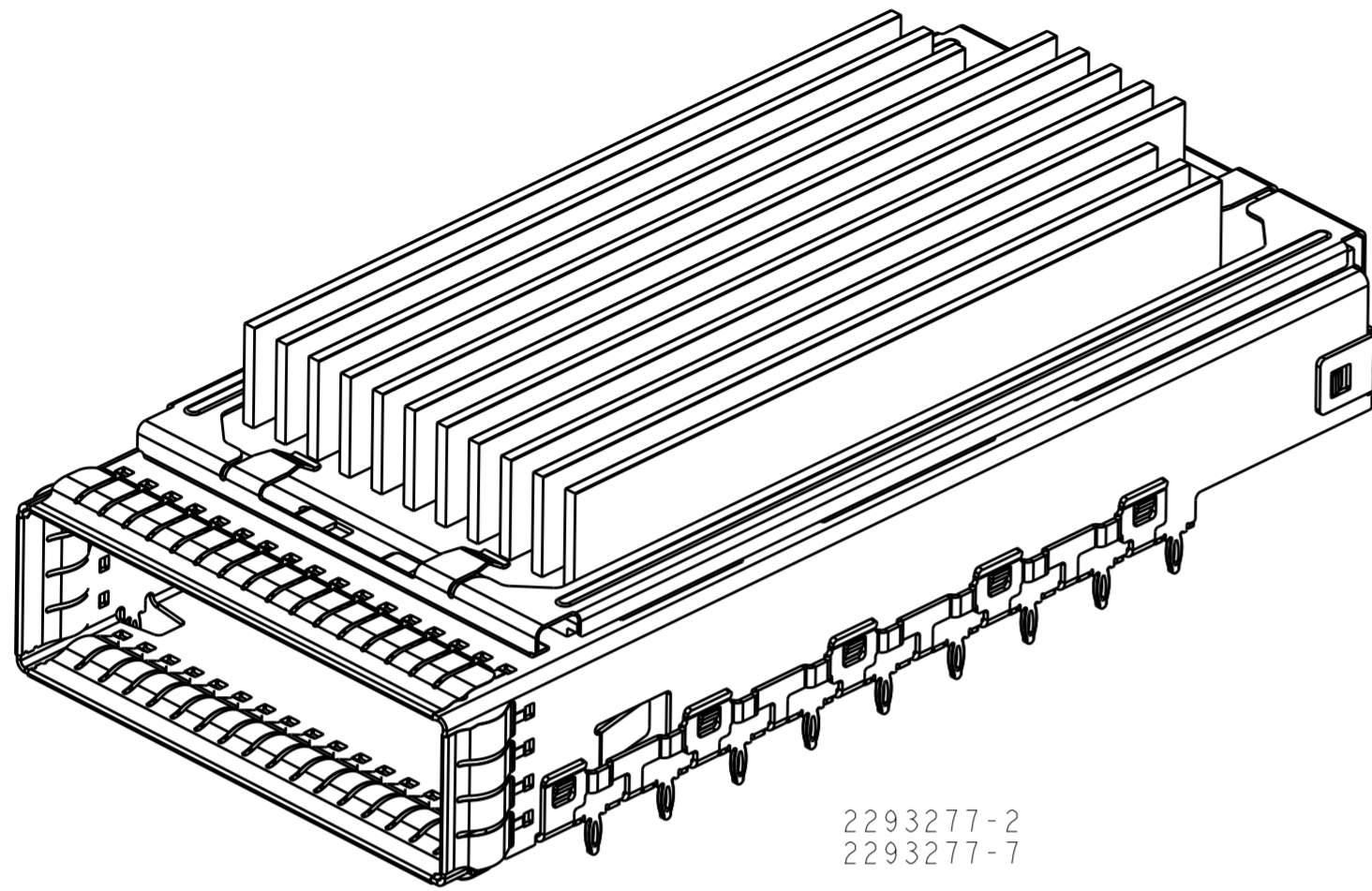

2293277-2
2293277-7

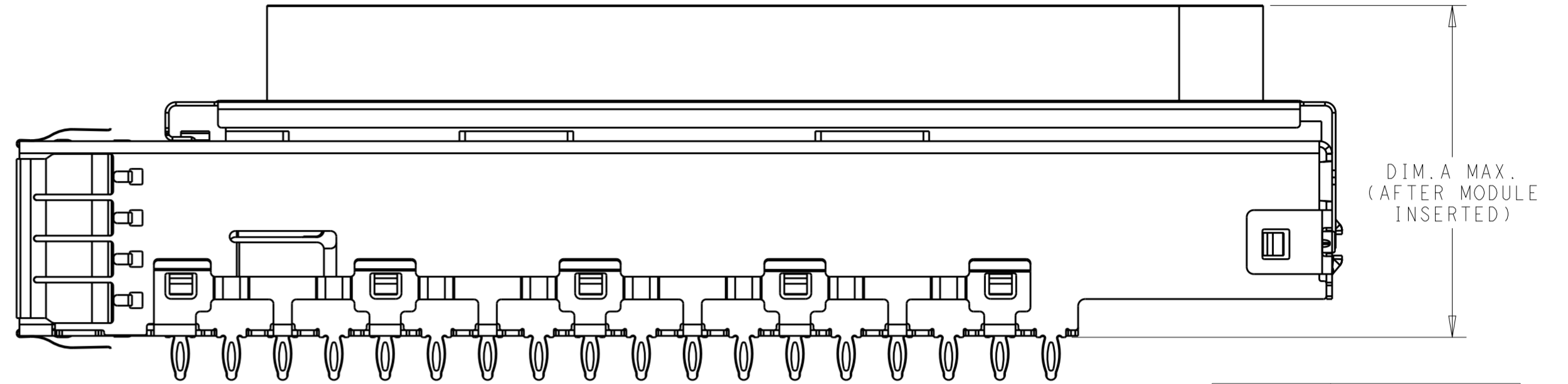

2293277-2&2293277-7
OTHER DIMENSIONS
SAME AS 2293277-1
SCALE 3:1

31.85	2293277-7
25	2293277-2
DIM. A	PART NUMBER

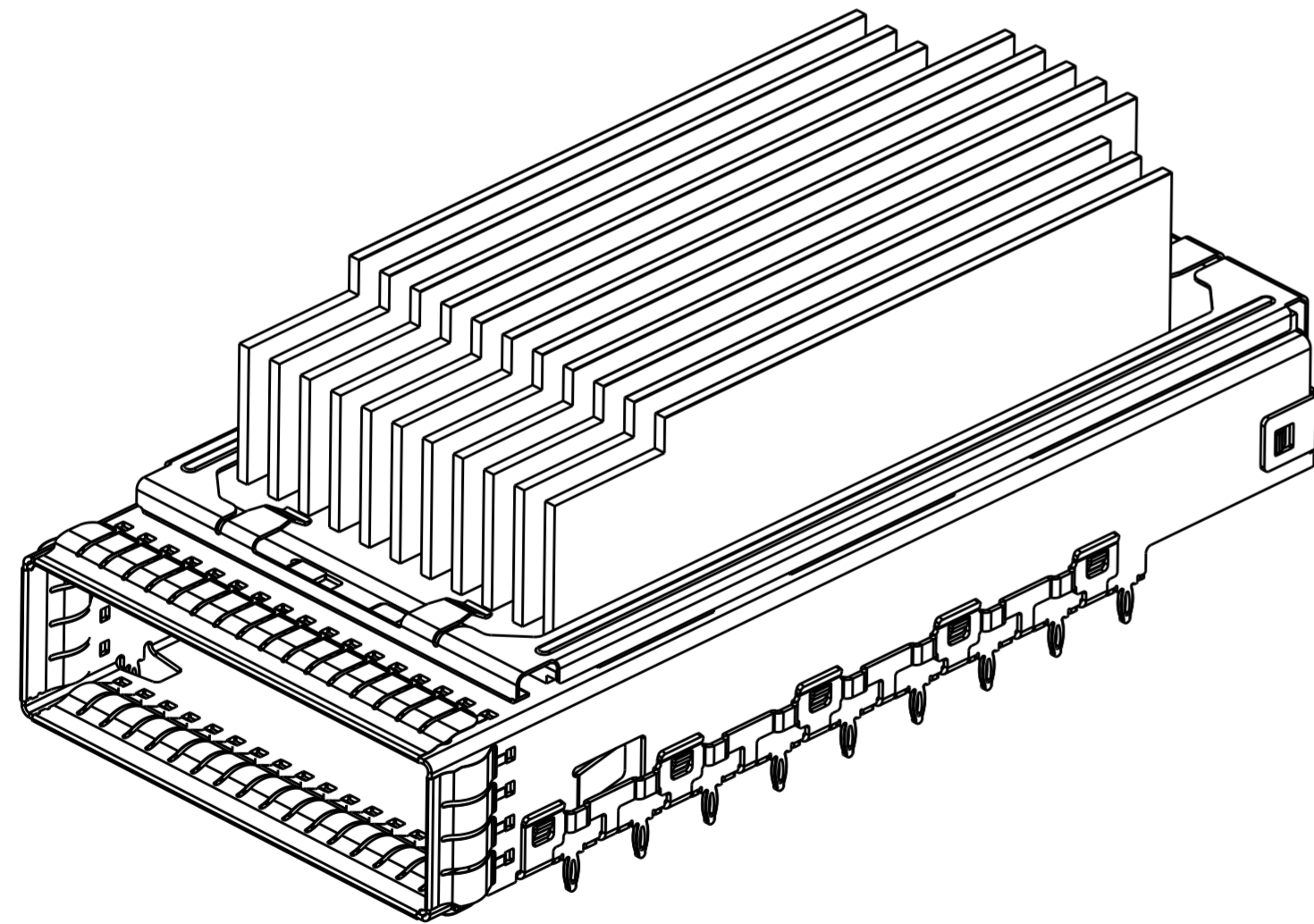

2293277-6

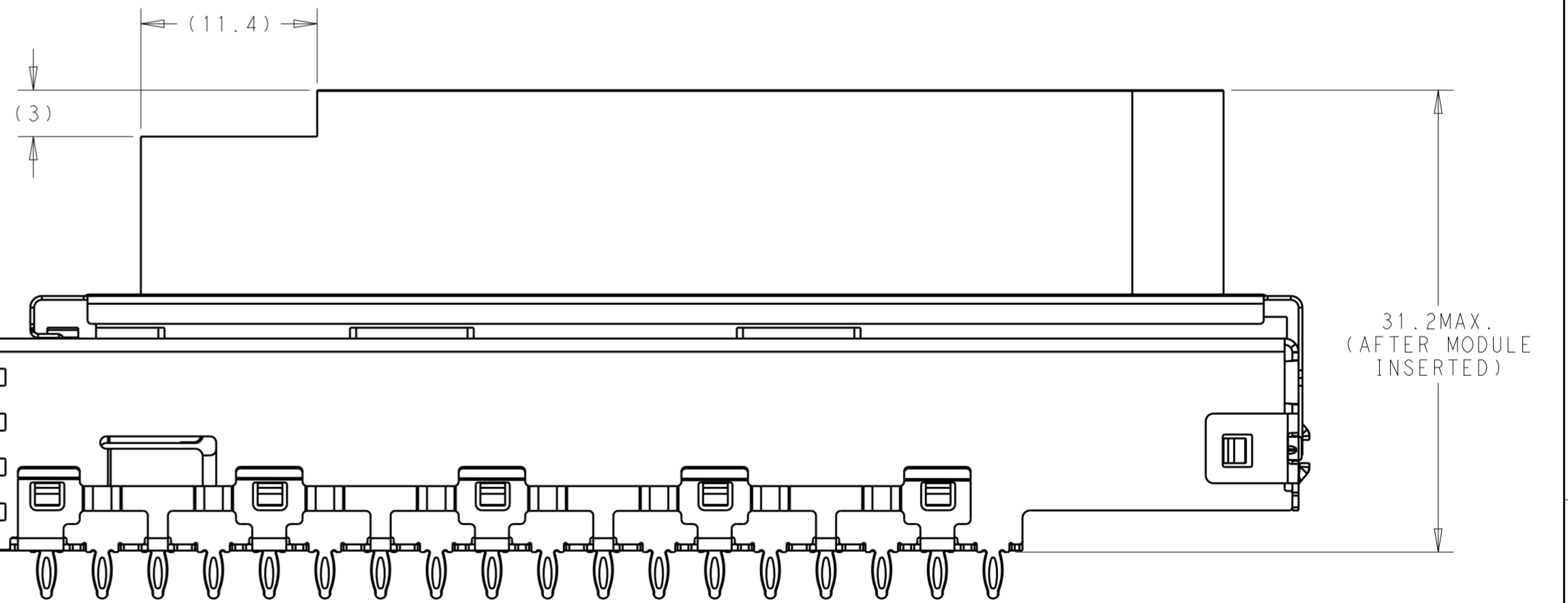

2293277-6 AS SHOWN, UNSPECIFIED
DIMENSION SAME AS 2293277-1

THIS DRAWING IS A CONTROLLED DOCUMENT.		DWN ANDY.XIE 17JUN2015	 TE Connectivity		
DIMENSIONS: mm		CHK -			
TOLERANCES UNLESS OTHERWISE SPECIFIED: 0 PLC ± 1 PLC ±0.25 2 PLC ±0.20 3 PLC ±0.1 4 PLC ±0.05 ANGLES ±1 FINISH		APVD SEAN.HAN 17JUN2015	NAME HARD WARE KIT FOR CFP2 1X1 PRESS FIT (CAGE, HS, HS CLIP, COVER, SCREW)		
MATERIAL SEE NOTES		PRODUCT SPEC 108-32103	SIZE A2	CAGE CODE -	DRAWING NO. C-2274842
FINISH -		APPLICATION SPEC 114-32146	RESTRICTED TO -	SCALE 1:1	SHEET 3 OF 9
-		WEIGHT -	CUSTOMER DRAWING	REV A1	

THIS DRAWING IS UNPUBLISHED. RELEASED FOR PUBLICATION 20
 © COPYRIGHT 20 BY - ALL RIGHTS RESERVED.

REVISIONS				
P	LTR	DESCRIPTION	DATE	APVD
-		SEE SHEET 1	-	-

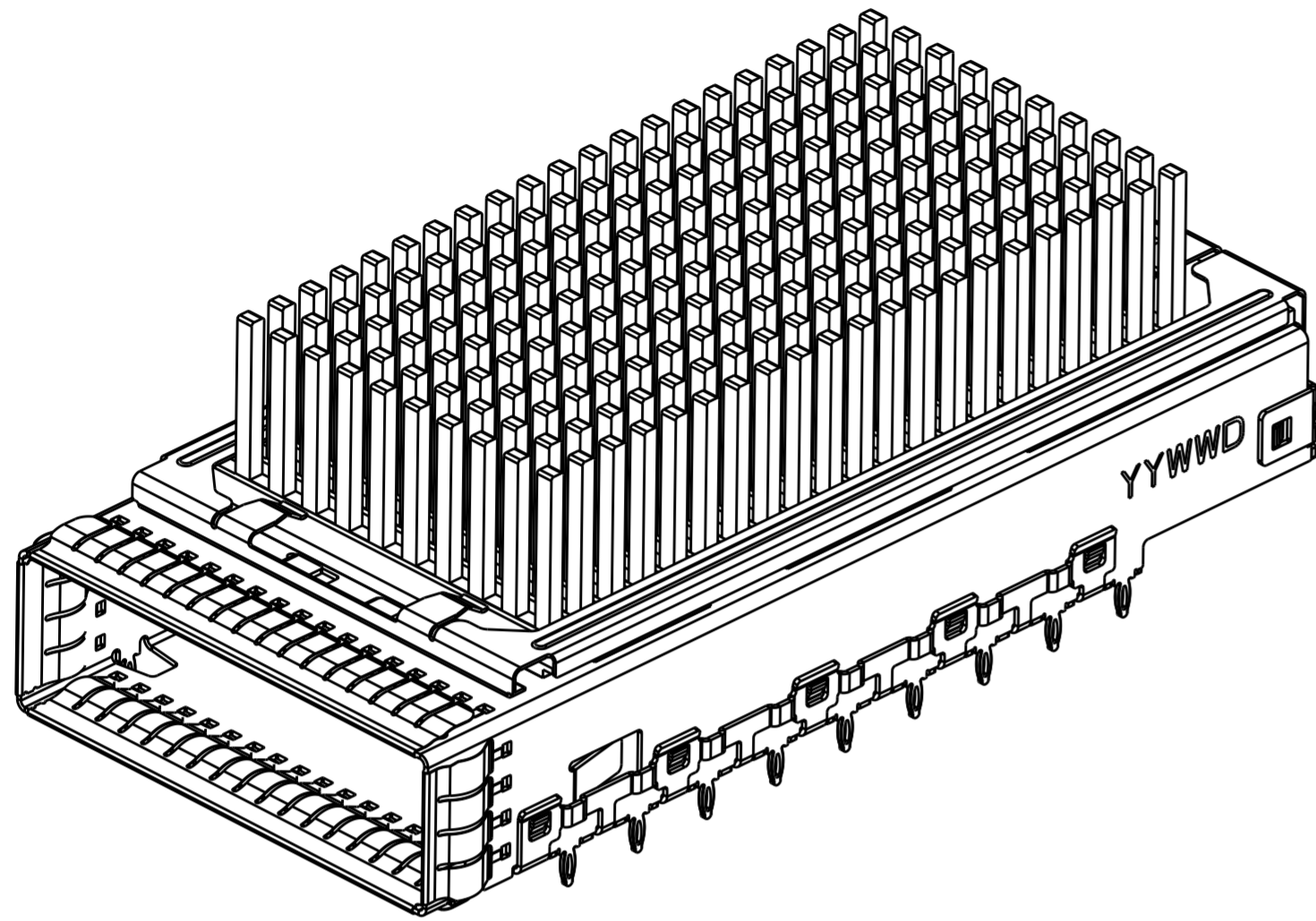

2293277-8 AS SHOWN

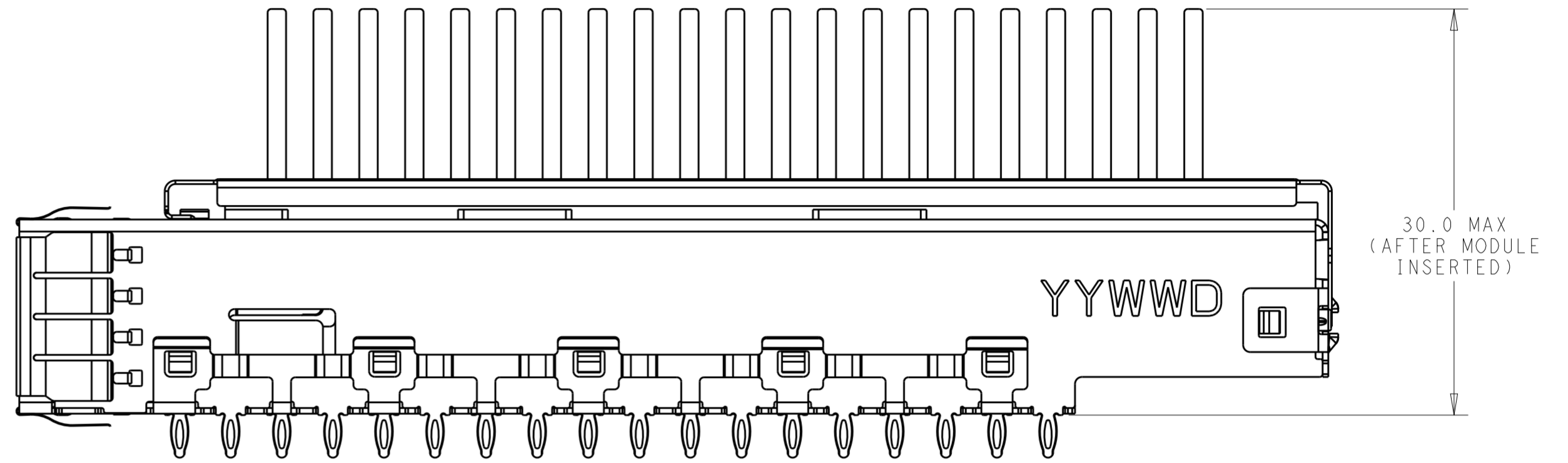

SCALE 3:1

THIS DRAWING IS A CONTROLLED DOCUMENT.		DWN ANDY.XIE CHK -	17JUN2015	 TE Connectivity	
DIMENSIONS: mm		APVD SEAN.HAN	17JUN2015		
TOLERANCES UNLESS OTHERWISE SPECIFIED: 0 PLC ± 1 PLC ±0.25 2 PLC ±0.20 3 PLC ±0.1 4 PLC ±0.05 ANGLES ±1 FINISH		NAME HARD WARE KIT FOR CFP2 1X1 PRESS FIT (CAGE, HS, HS CLIP, COVER, SCREW)		SIZE A2	
MATERIAL SEE NOTES		PRODUCT SPEC 108-32103 APPLICATION SPEC 114-32146		CAGE CODE -	
FINISH SEE NOTES		WEIGHT -		DRAWING NO C-2274842	
		CUSTOMER DRAWING		SCALE 1:1	SHEET 4 OF 9
				REV A1	

THIS DRAWING IS UNPUBLISHED. RELEASED FOR PUBLICATION 20
 © COPYRIGHT 20 BY - ALL RIGHTS RESERVED.

REVISIONS					
P	LTR	DESCRIPTION	DATE	DWN	APVD
-	-	SEE SHEET 1	-	-	-

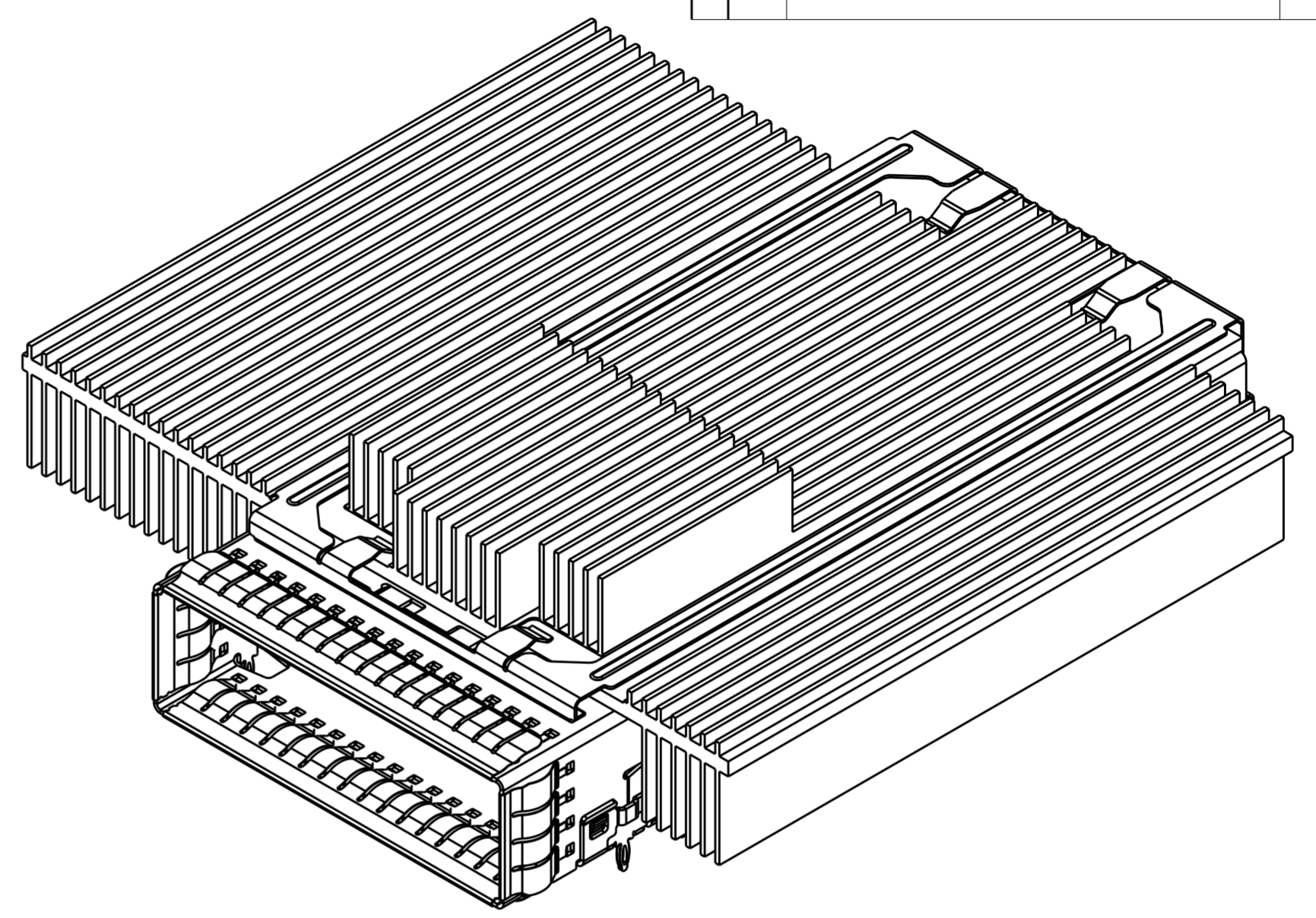
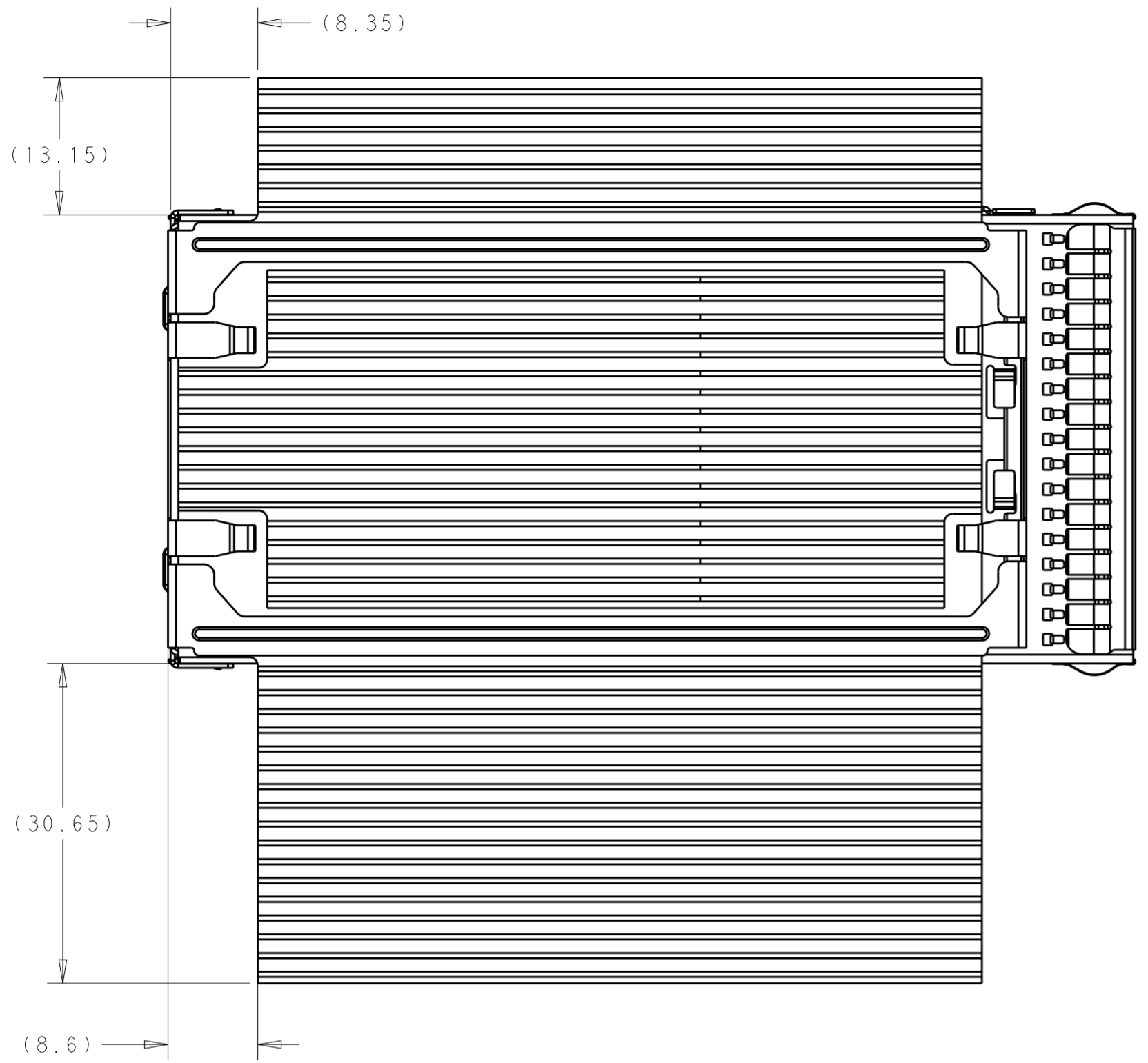

2293277-9 3D VIEW
SCALE 2:1

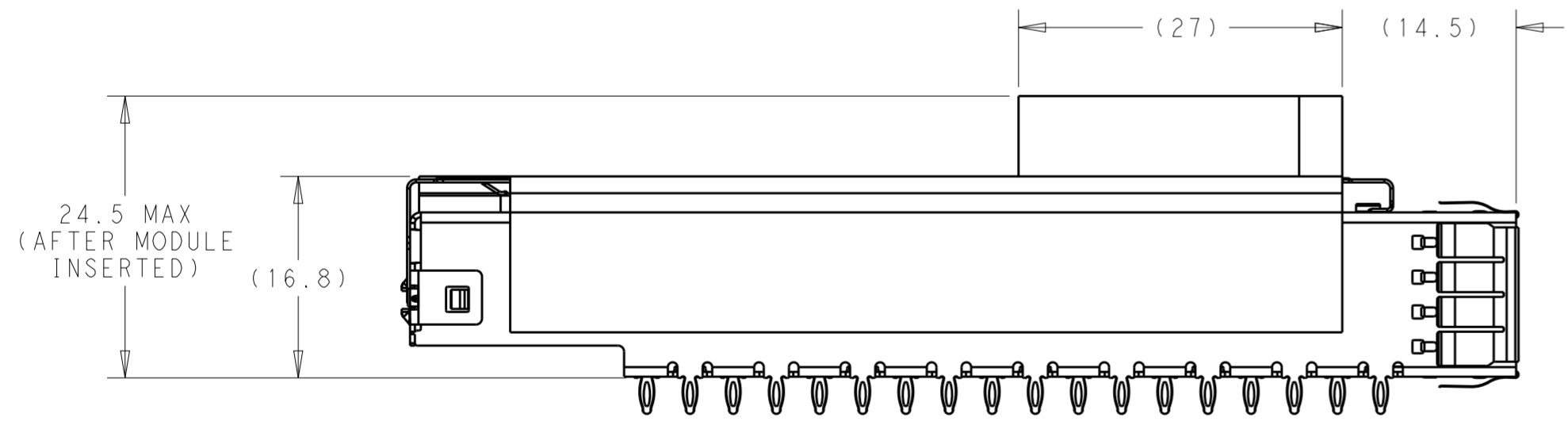

2293277-9 AS SHOWN

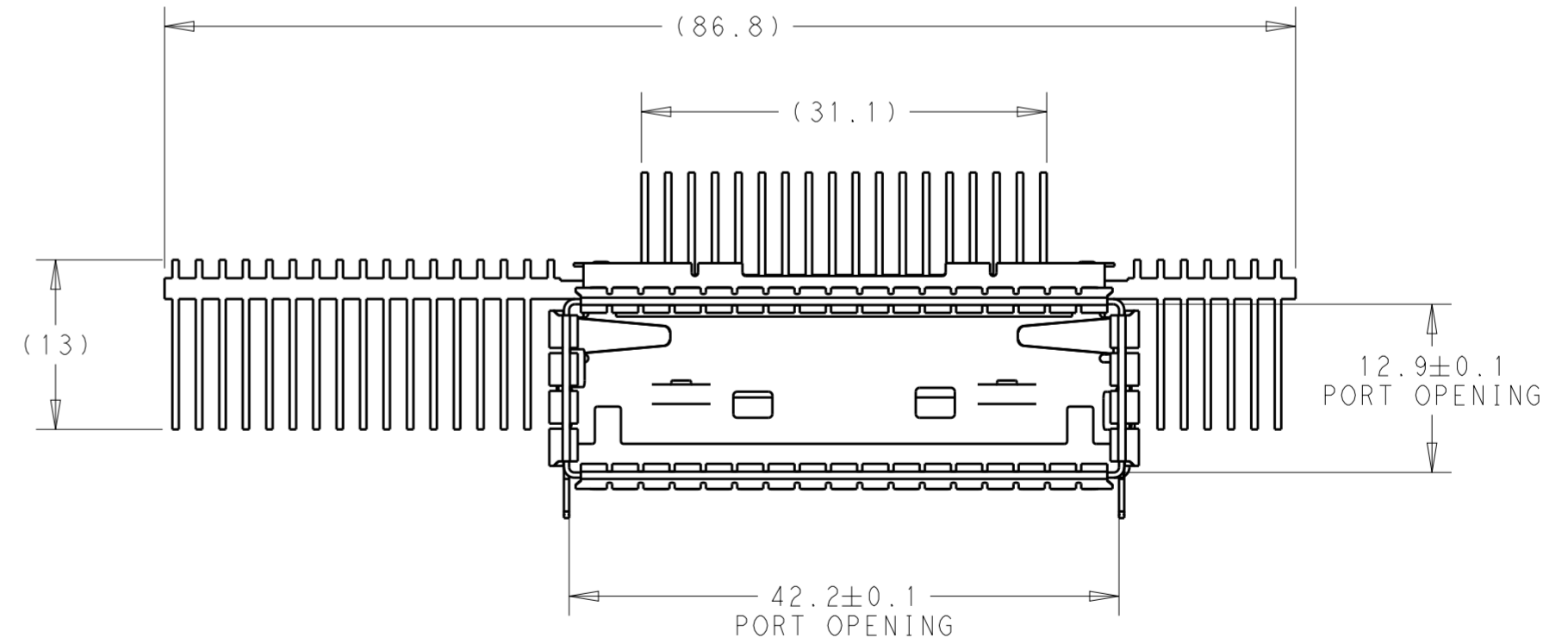

THIS DRAWING IS A CONTROLLED DOCUMENT.		DWN ANDY.XIE 17JUN2015	TE Connectivity		
DIMENSIONS: mm		CHK - APVD SEAN.HAN 17JUN2015			
TOLERANCES UNLESS OTHERWISE SPECIFIED:		PRODUCT SPEC 108-32103	NAME HARD WARE KIT FOR CFP2 1X1 PRESS FIT (CAGE, HS, HS CLIP, COVER, SCREW)		
0 PLC ± 1 PLC ±0.25 2 PLC ±0.20 3 PLC ±0.1 4 PLC ±0.05 ANGLES ±1 FINISH		APPLICATION SPEC 114-32146	SIZE A2	CAGE CODE -	DRAWING NO G-2274842
MATERIAL SEE NOTES		WEIGHT -	RESTRICTED TO -		
CUSTOMER DRAWING		SCALE 1:1	SHEET 5 OF 9		REV A1

THIS DRAWING IS UNPUBLISHED. RELEASED FOR PUBLICATION 20
 © COPYRIGHT 20 BY - ALL RIGHTS RESERVED.

REVISIONS				
P	LTR	DESCRIPTION	DATE	APVD
-	-	SEE SHEET 1	-	-

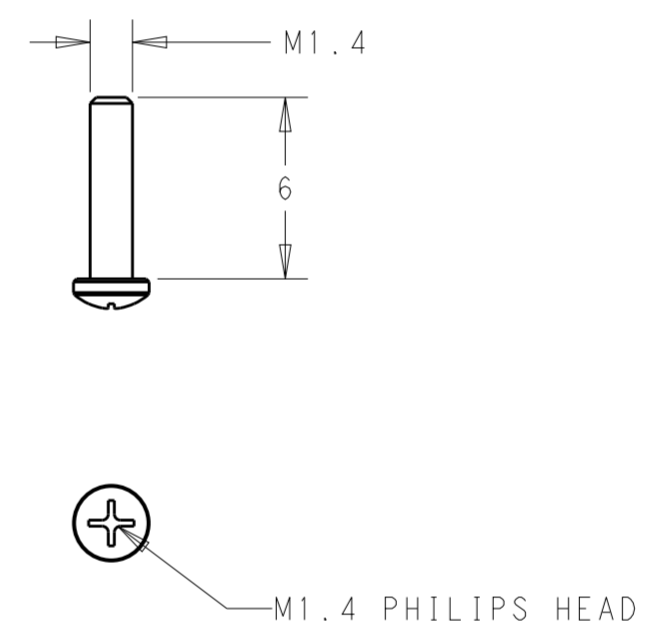
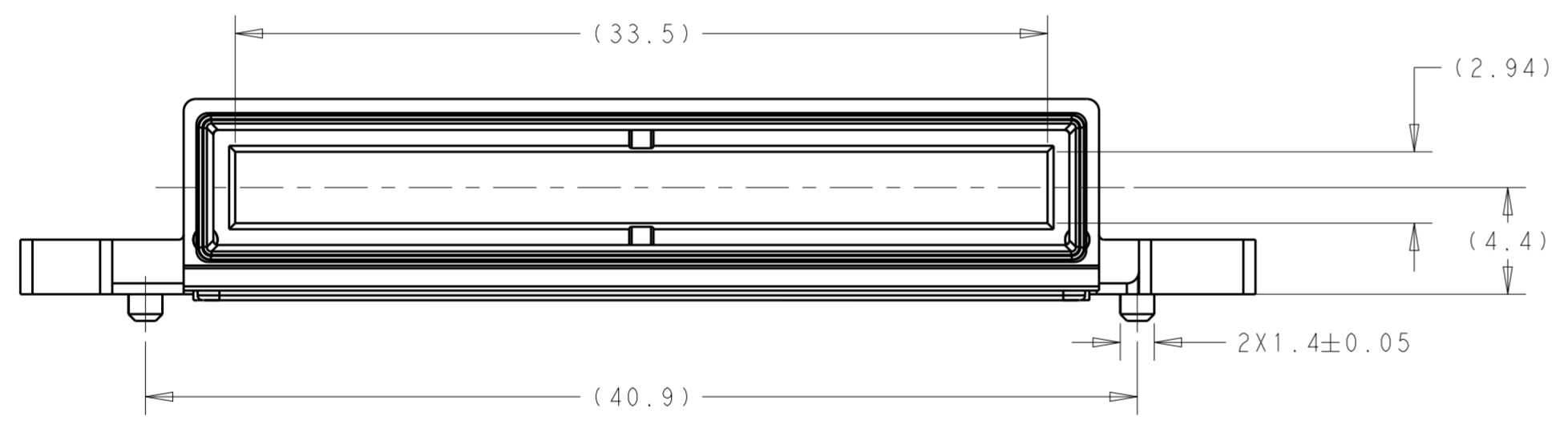
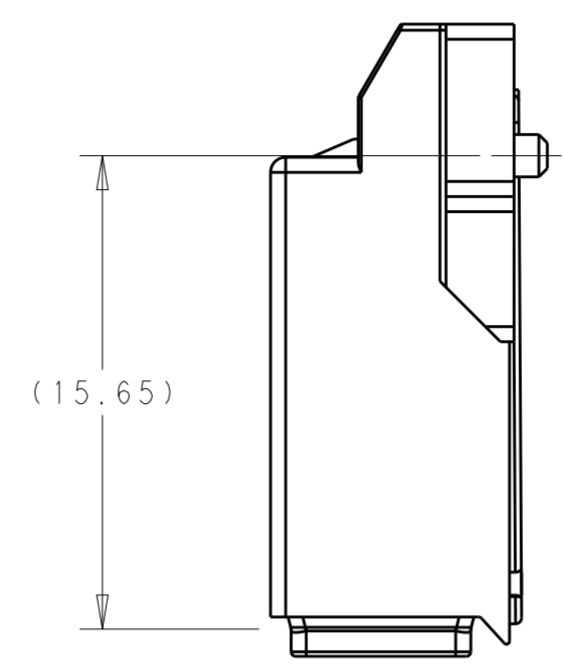
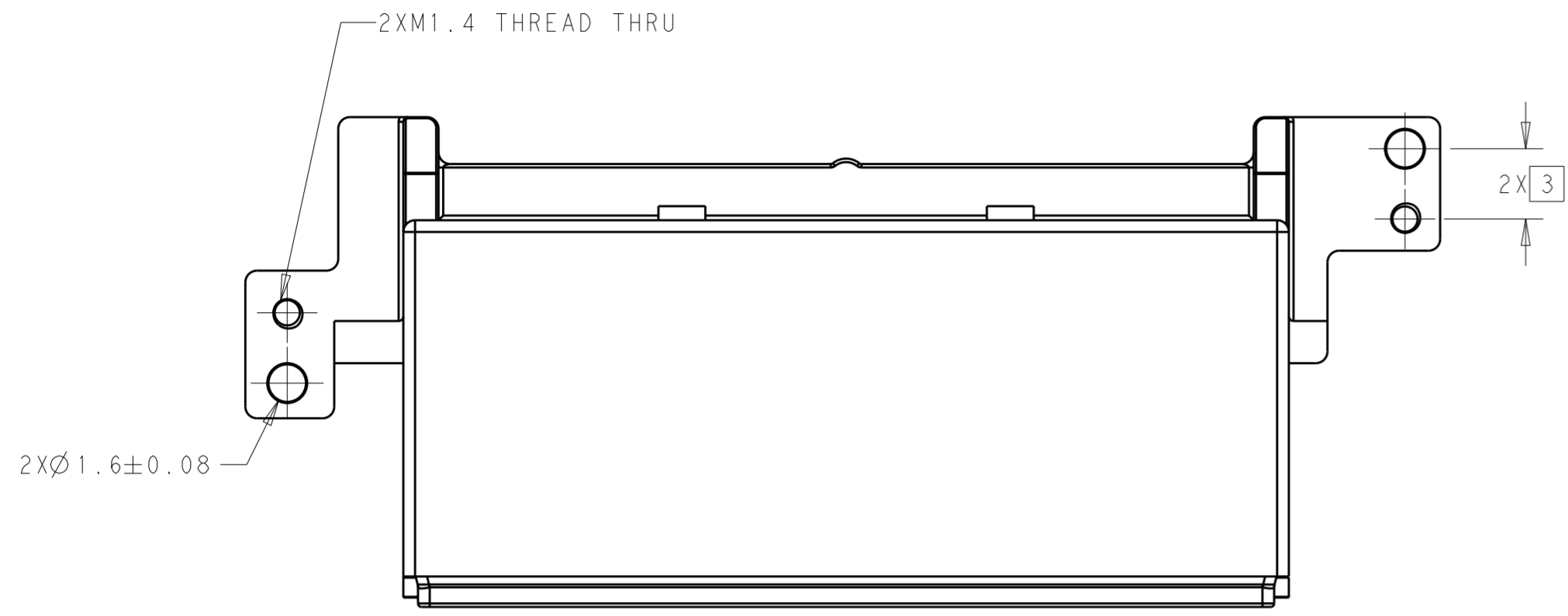

SCALE 4:1

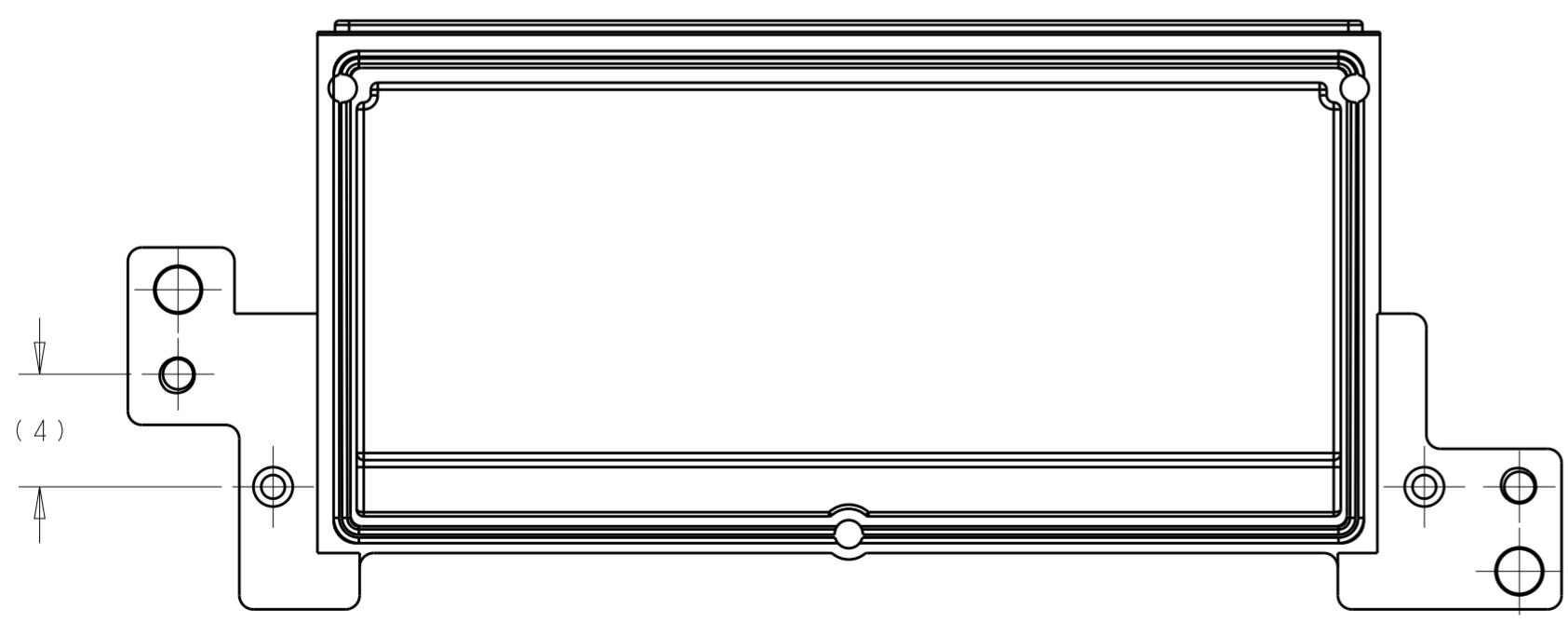

THIS DRAWING IS A CONTROLLED DOCUMENT.		DWN ANDY.XIE 17JUN2015	TE Connectivity	
DIMENSIONS: mm		CHK -		
TOLERANCES UNLESS OTHERWISE SPECIFIED:		APVD SEAN.HAN 17JUN2015	NAME HARD WARE KIT FOR CFP2 1X1	
0 PLC ±		PRODUCT SPEC 108-32103	PRESS FIT	
1 PLC ±0.25		APPLICATION SPEC 114-32146	(CAGE, HS, HS CLIP, COVER, SCREW)	
2 PLC ±0.20		WEIGHT -	SIZE A2	CAGE CODE -
3 PLC ±0.1		CUSTOMER DRAWING	DRAWING NO C-2274842	RESTRICTED TO -
4 PLC ±0.05		SCALE 1:1	SHEET 6 OF 9	REV A1
ANGLES ±1				
FINISH				
MATERIAL SEE NOTES				
SEE NOTES				

THIS DRAWING IS UNPUBLISHED. RELEASED FOR PUBLICATION 20
 © COPYRIGHT 20 BY - ALL RIGHTS RESERVED.

REVISIONS					
P	LTR	DESCRIPTION	DATE	DWN	APVD
-	-	SEE SHEET 1	-	-	-

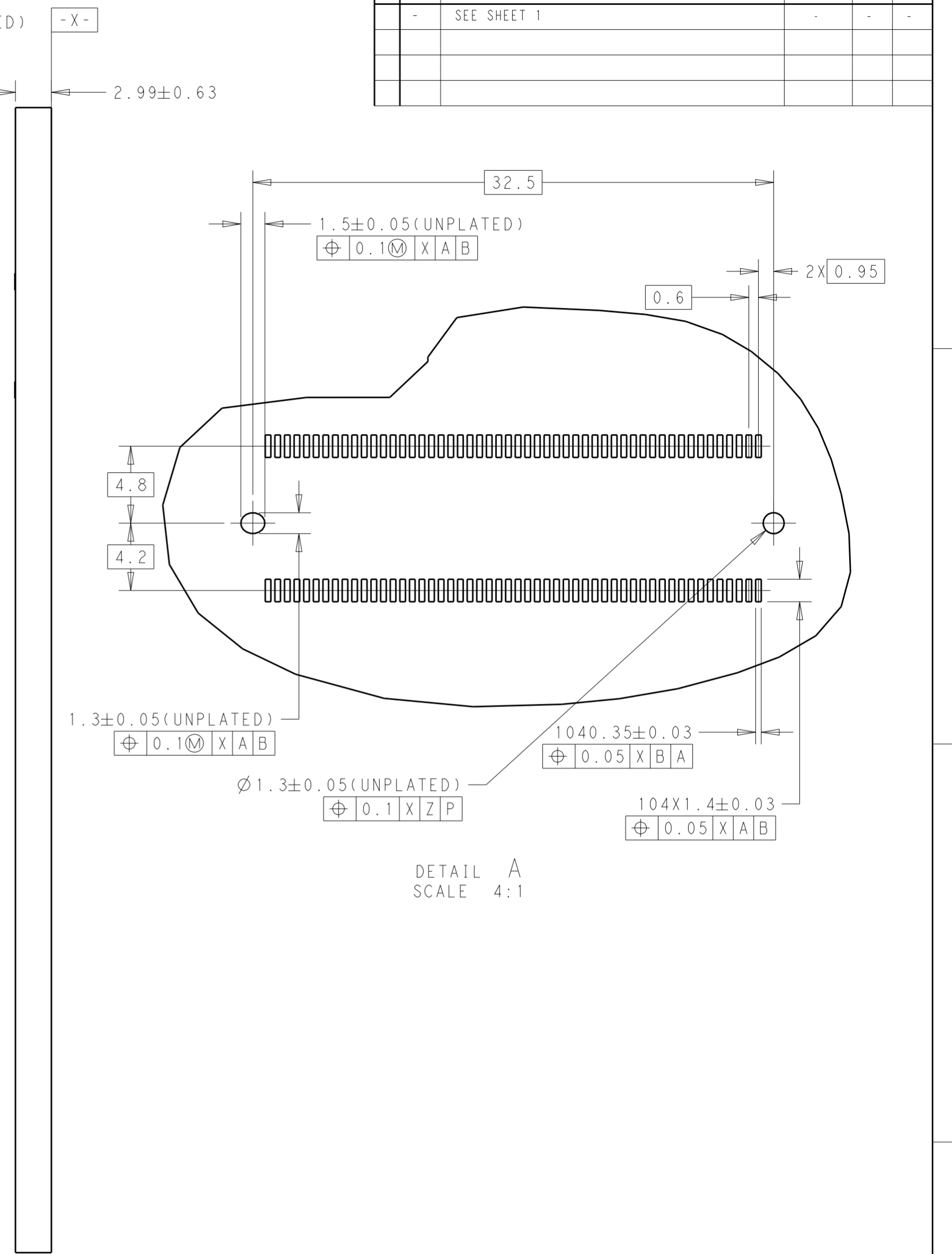
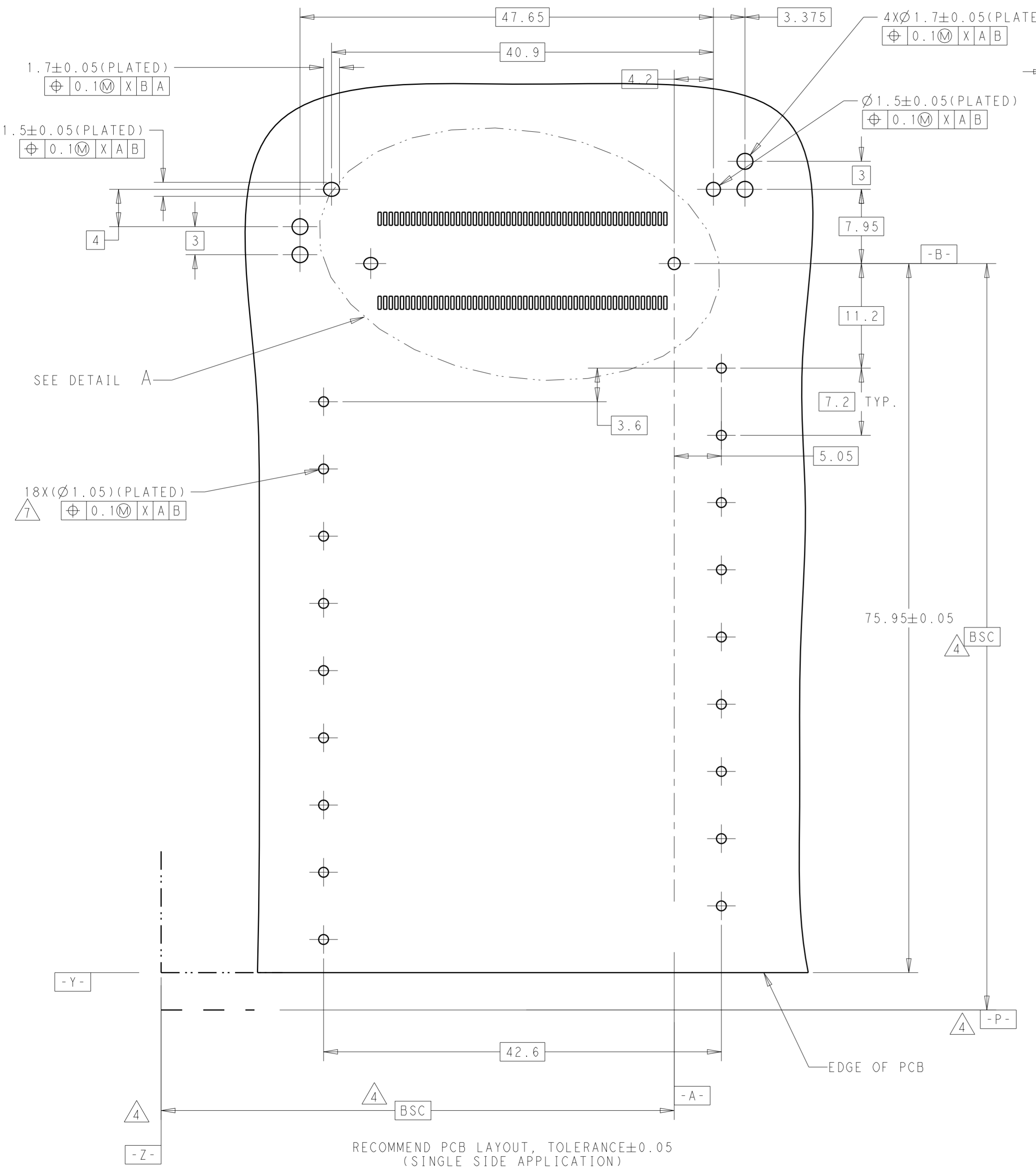

THIS DRAWING IS A CONTROLLED DOCUMENT.		DWN ANDY.XIE 17JUN2015	TE Connectivity		
DIMENSIONS: mm		CHK SEAN.HAN 17JUN2015			
TOLERANCES UNLESS OTHERWISE SPECIFIED:		APVD SEAN.HAN 17JUN2015	NAME HARD WARE KIT FOR CFP2 1X1 PRESS FIT (CAGE, HS, HS CLIP, COVER, SCREW)		
0 PLC ±		PRODUCT SPEC 108-32103	SIZE A2		
1 PLC ±0.25		APPLICATION SPEC 114-32146	CAGE CODE -		
2 PLC ±0.20		WEIGHT -	DRAWING NO C-2274842		
3 PLC ±0.1		CUSTOMER DRAWING	RESTRICTED TO -		
4 PLC ±0.05			SCALE 1:1 SHEET 7 OF 9 REV A1		
ANGLES ±1					
FINISH SEE NOTES					
MATERIAL SEE NOTES					

THIS DRAWING IS UNPUBLISHED. RELEASED FOR PUBLICATION 20
 © COPYRIGHT 20 BY - ALL RIGHTS RESERVED.

REVISIONS				
P	LTR	DESCRIPTION	DATE	APVD
-		SEE SHEET 1	-	-

CROSS-HATCHED DENOTES COMPONENT AND TRACE KEEP-OUT AREA (EXCEPT CHASSIS GROUND) FOR NON-MAYLARTAPE APPLICATION. COMPONENTS AND TRACES ARE ONLY ALLOWED FOR APPLICATION WITH MYLAR TAPE

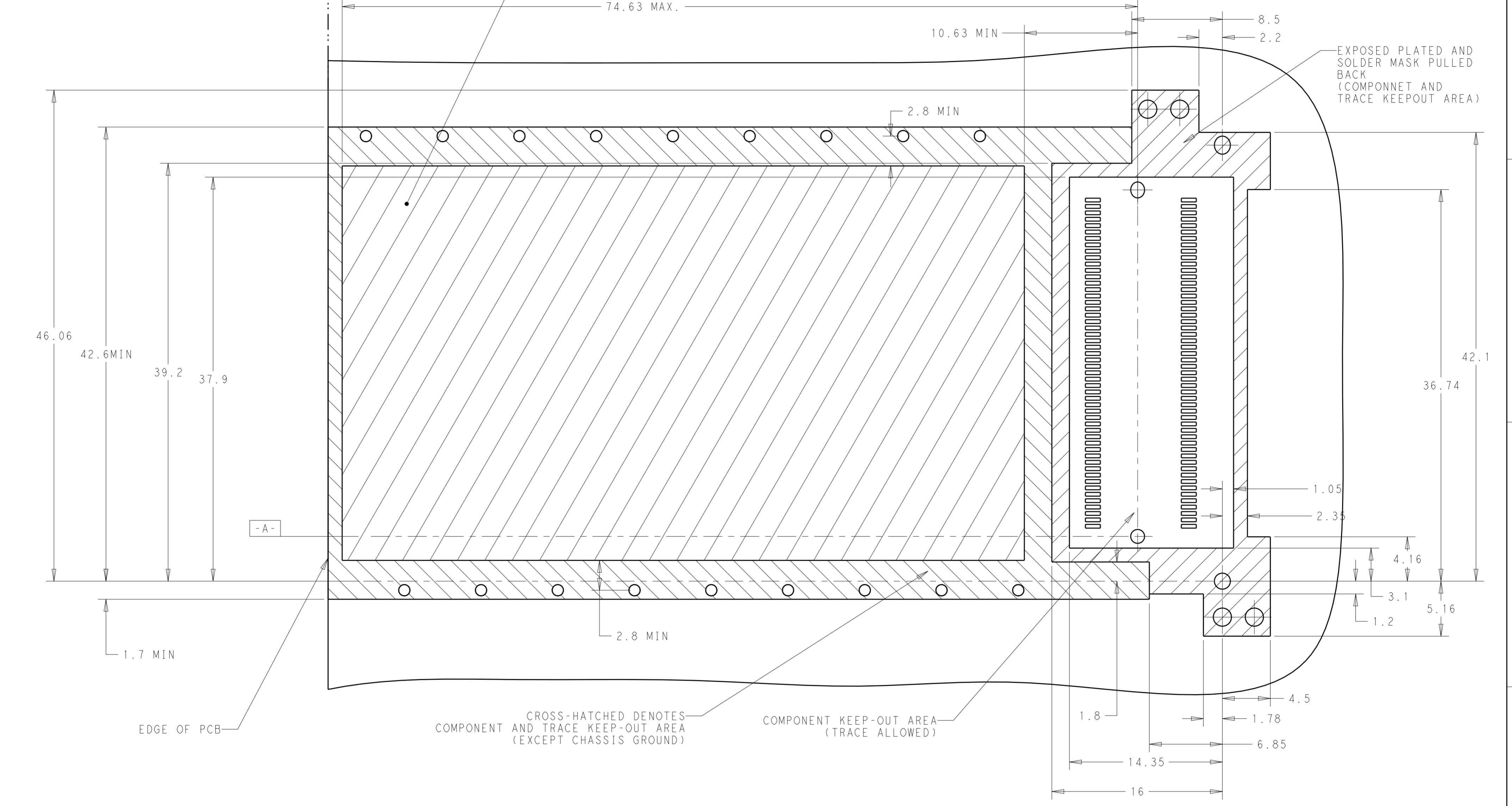

THIS DRAWING IS A CONTROLLED DOCUMENT.		DWN ANDY.XIE 17 JUN 2015	TE Connectivity	
DIMENSIONS: mm		CHK -		
TOLERANCES UNLESS OTHERWISE SPECIFIED:		APVD SEAN.HAN 17 JUN 2015	NAME HARD WARE KIT FOR CFP2 1X1 PRESS FIT (CAGE, HS, HS CLIP, COVER, SCREW)	
0 PLC ±		PRODUCT SPEC 108-32103	SIZE A2	CAGE CODE -
1 PLC ±0.25		APPLICATION SPEC 114-32146	DRAWING NO G-2274842	RESTRICTED TO -
2 PLC ±0.20		WEIGHT -	SCALE 1:1	SHEET 8 OF 9
3 PLC ±0.1		CUSTOMER DRAWING	REV A1	
4 PLC ±0.05				
ANGLES ±1				
FINISH SEE NOTES				

THIS DRAWING IS UNPUBLISHED. RELEASED FOR PUBLICATION 20
 © COPYRIGHT 20 BY - ALL RIGHTS RESERVED.

REVISIONS				
P	LTR	DESCRIPTION	DATE	APVD
-	-	SEE SHEET 1	-	-

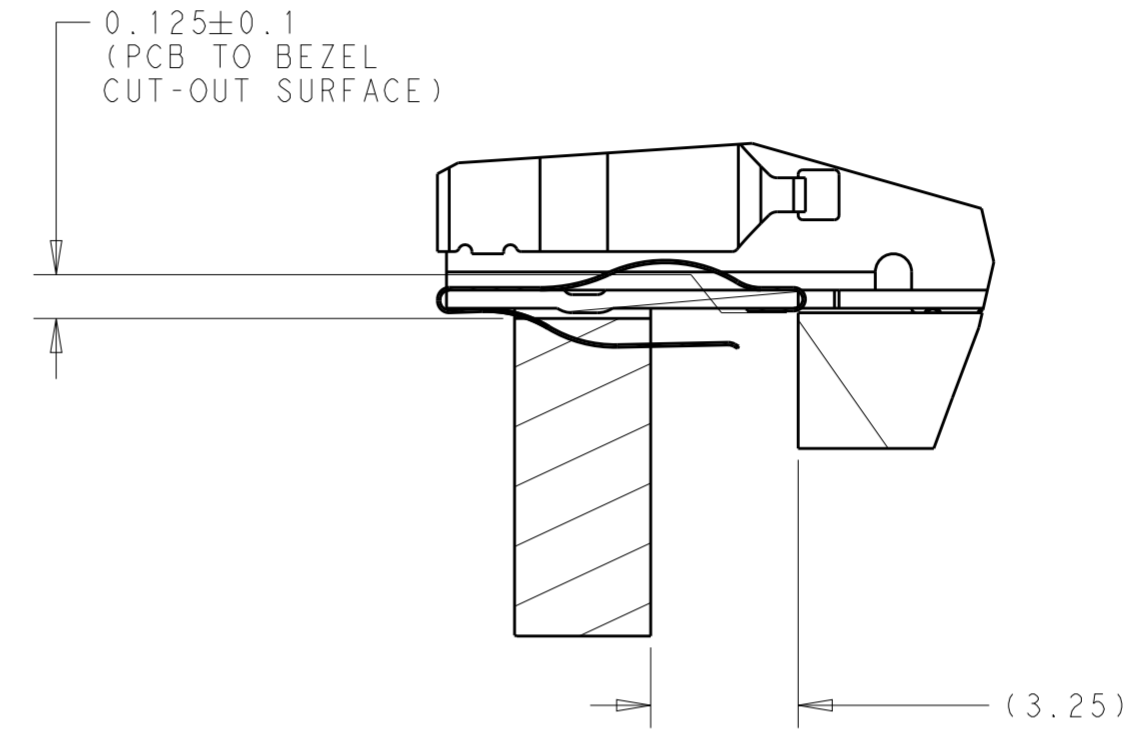
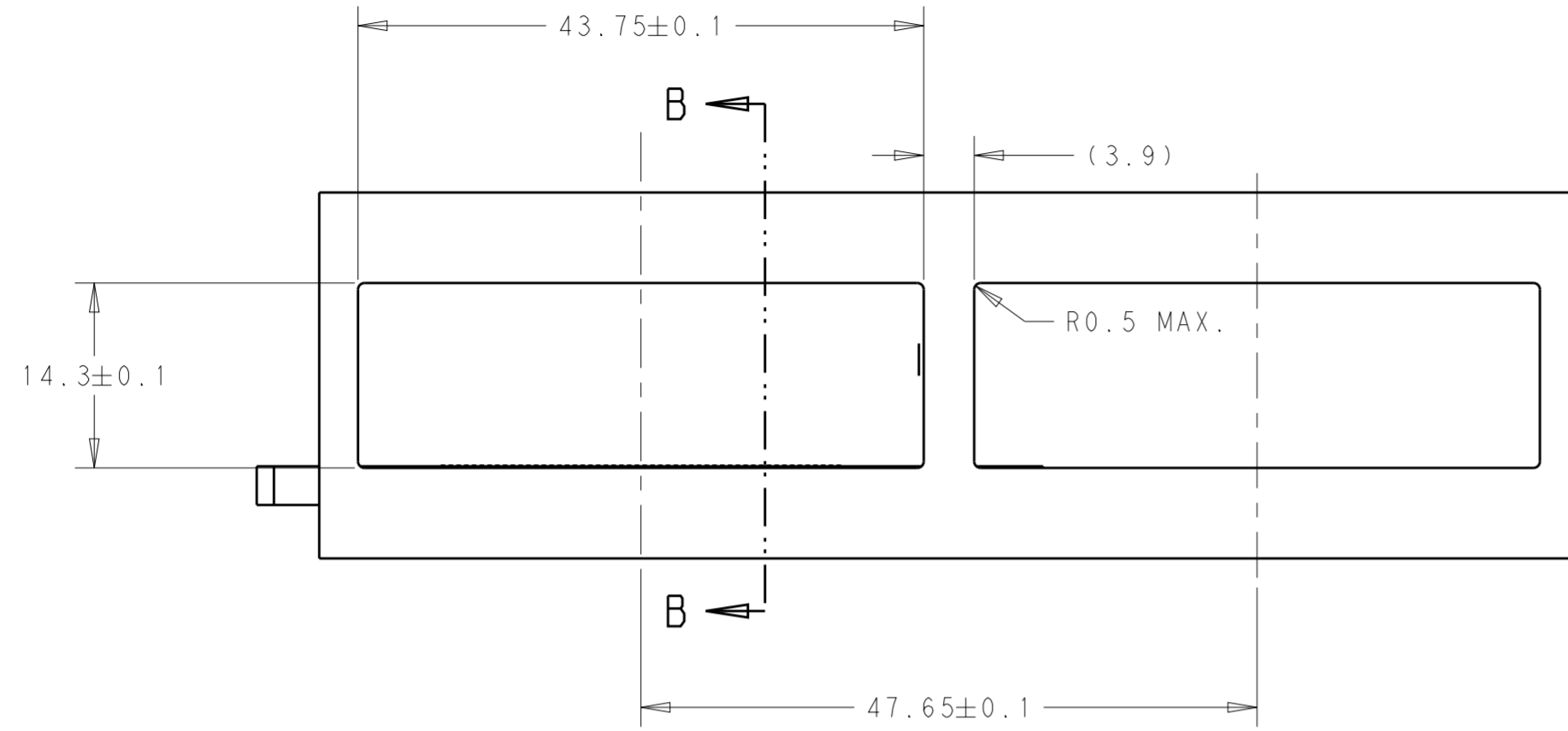

DETAIL B
SCALE 6:1

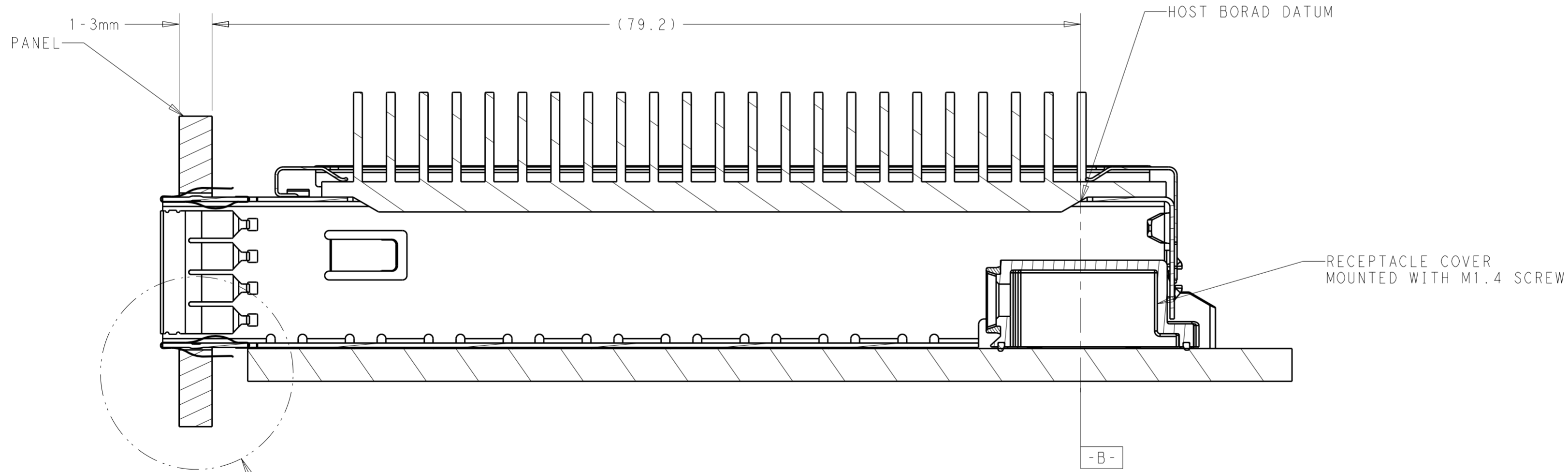

SECTION B-B
SCALE 3:1

SEE DETAIL B

THIS DRAWING IS A CONTROLLED DOCUMENT.		DWN ANDY.XIE 17JUN2015	TE Connectivity	
DIMENSIONS: mm		CHK -		
TOLERANCES UNLESS OTHERWISE SPECIFIED:		APVD SEAN.HAN 17JUN2015	NAME HARD WARE KIT FOR CFP2 1X1	
0 PLC ±		PRODUCT SPEC 108-32103	PRESS FIT	
1 PLC ±0.25		APPLICATION SPEC 114-32146	(CAGE, HS, HS CLIP, COVER, SCREW)	
2 PLC ±0.20		WEIGHT -	SIZE A2	RESTRICTED TO -
3 PLC ±0.1		CUSTOMER DRAWING	CAGE CODE -	DRAWING NO. C-2274842
4 PLC ±0.05		SCALE 1:1	SHEET 9 OF 9	REV A1
ANGLES ±1				
FINISH				
MATERIAL SEE NOTES				
SEE NOTES				