

REVISIONS				
P	LTN	DESCRIPTION	DATE	APVD
A		RELEASED	15MAY2019	CJV JW
B		REVISED PER ECO-19-011736	06AUG2019	AP JW

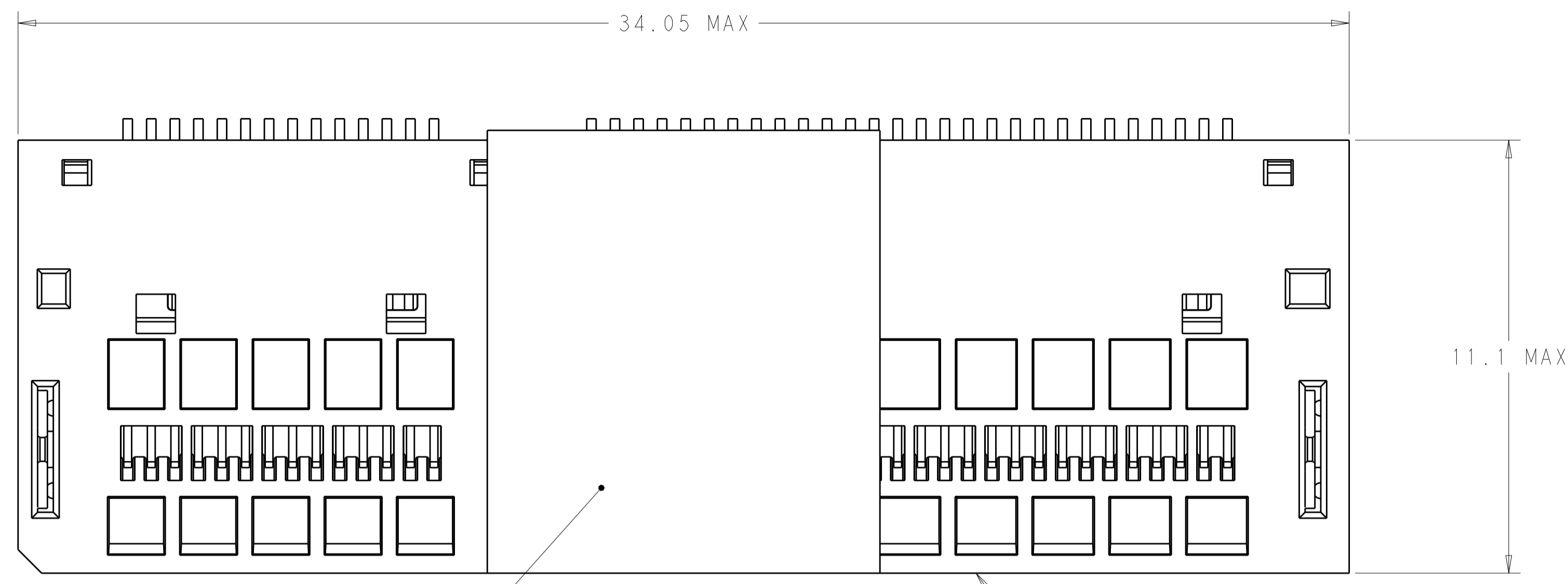

- 1 HOUSING, ORGANIZER, CONTACT OVERMOLDS - LCP, UL94-V0, BLACK. CONTACTS AND HOLD DOWNS - COPPER ALLOY. PICK AND PLACE TAPE - POLYIMIDE FILM.
- 2 CONTACTS - GOLD PLATE ON MATING SURFACES, TIN PLATE ON SOLDER FEET. HOLD DOWNS - TIN PLATE.
- 3 DATUMS AND BASIC DIMENSIONS ESTABLISHED BY CUSTOMER.
- 4. MINIMUM HOST PCB THICKNESS: 1.5.
- 5 SEE MSA SPECIFICATION FOR ADDITIONAL PADDLE CARD LAYOUTS COMPATIBLE WITH THIS RECEPTACLE AND FOR OPTIONAL SPLIT CONTACT PAD LAYOUTS FOR THE PADDLE CARD. SPECIFICATION PINOUT MAY ALSO DESIGNATE PAD SEQUENCE DIFFERENT FROM ILLUSTRATION.
- 6 POSITIONS DESIGNATED AS "SIGNAL" ARE REQUIRED LOCATIONS FOR HIGH SPEED DIFFERENTIAL PAIR SIGNALING. THESE LOCATIONS MAY ALSO BE USED FOR SUPPORTING SIDEBAND SIGNALS OR OTHER UTILITY PURPOSES. POSITIONS DESIGNATED AS "GROUND" ARE REQUIRED WHEN SUPPORTING HIGH SPEED DIFFERENTIAL SIGNALS. THESE LOCATIONS MAY ALSO BE USED FOR SIDEBAND SIGNALS OR OTHER UTILITY PURPOSES.
- 7 COMPONENT AND TRACE KEEP OUT AREA. EACH EDGE 0.15 MIN FROM EDGE OF HOLE.
- 8 TAPE AND REEL PACKAGED FOR PICK AND PLACE SMT PROCESSING, SEE FIGURE 1. POCKET TAPE WIDTH = 56.

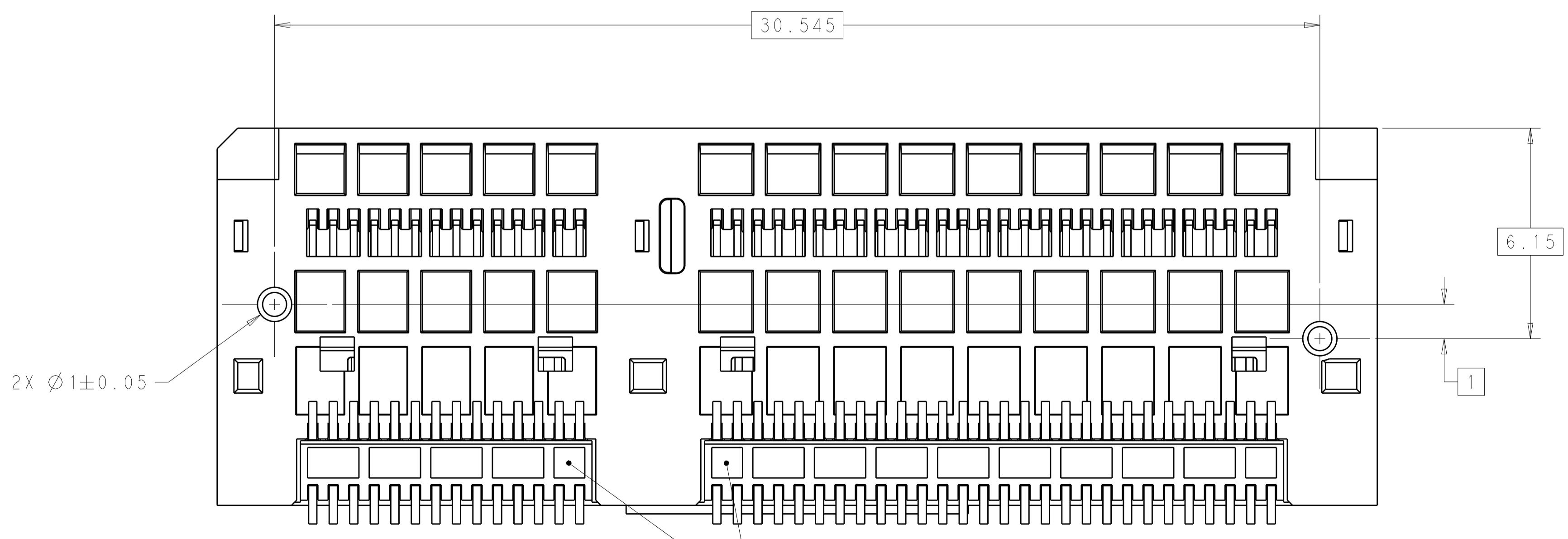
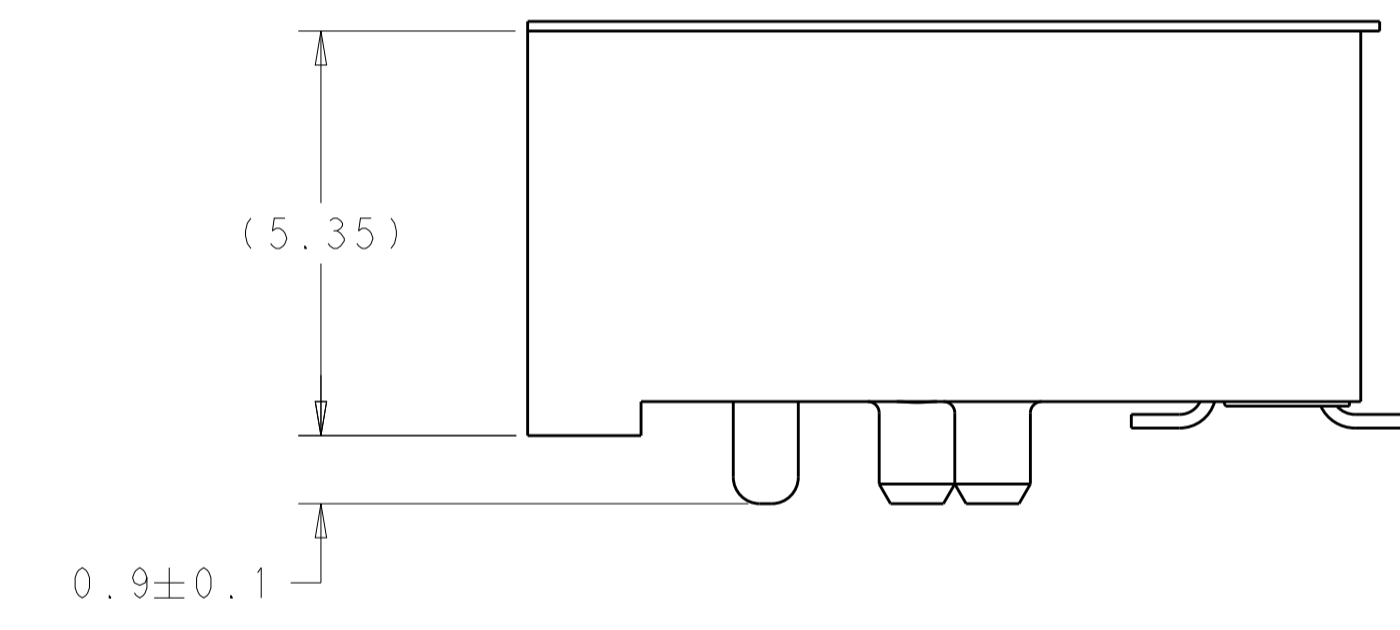
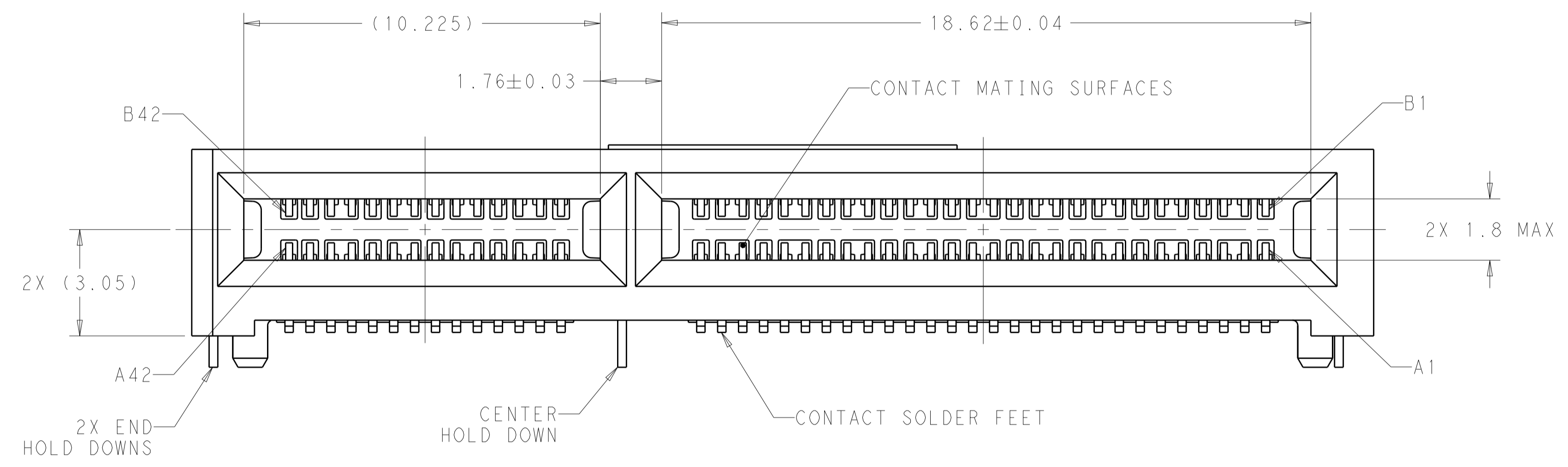

SEE SHEET 4 FOR PART TABLE

THIS DRAWING IS A CONTROLLED DOCUMENT.		OWN: M. SHIRK 22FEB2018		
DIMENSIONS: mm		CHK: D. HARMON 22FEB2018		
TOLERANCES UNLESS OTHERWISE SPECIFIED:		APVD: D. HARMON 22FEB2018	NAME: RECEPTACLE ASSEMBLY, RIGHT ANGLE, 84 POSITION, SILVER 2.0	
0 PLC ±	1 PLC ±	PRODUCT SPEC: 108-130021	SIZE: A1	
2 PLC ±	3 PLC ±	APPLICATION SPEC: 114-130008	CAGE CODE: -	
4 PLC ±	ANGLES ±	WEIGHT: -	SCALE: 10:1	
MATERIAL:	FINISH:	CUSTOMER DRAWING	SHEET 1 OF 4	
		REV B		

REVISIONS				
P.	LTN.	DESCRIPTION	DATE	APPV.
-	-	SEE SHEET 1	-	-

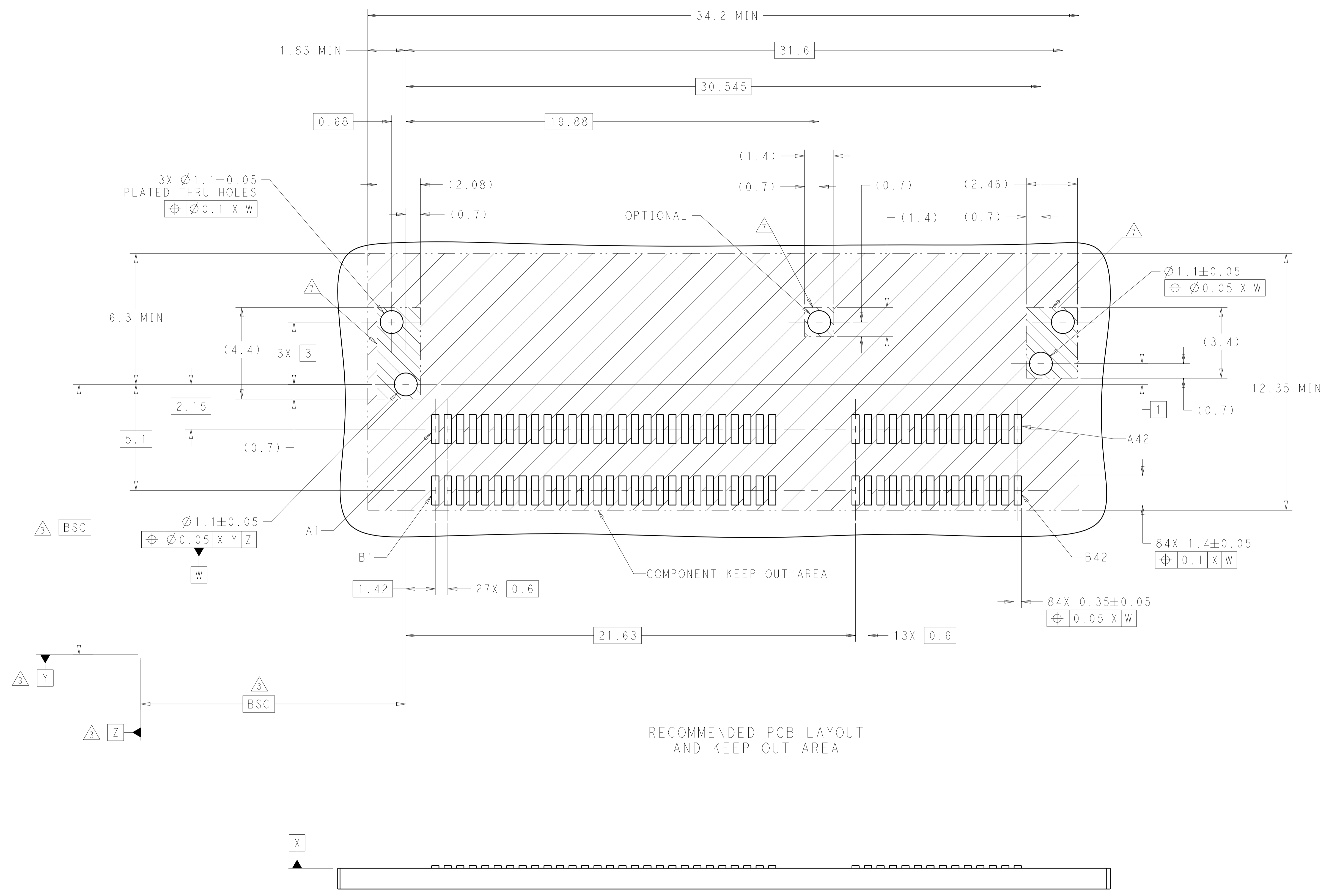

THIS DRAWING IS A CONTROLLED DOCUMENT.		OWN: M. SHIRK 22FEB2018	TE Connectivity
DIMENSIONS: mm		CHK: D. HARMON 22FEB2018	
TOLERANCES UNLESS OTHERWISE SPECIFIED: 0 PLC \pm 1 PLC \pm 2 PLC \pm 3 PLC \pm 4 PLC \pm ANGLES \pm MATERIAL FINISH		APVD: D. HARMON 22FEB2018 PRODUCT SPEC: 108-130021 APPLICATION SPEC: 114-130008 WEIGHT: -	NAME: RECEPTACLE ASSEMBLY, RIGHT ANGLE, 84 POSITION, SILVER 2.0 SIZE: A1 CAGE CODE: - DRAWING NO: C=2327671 RESTRICTED TO: -
MATERIAL		CUSTOMER DRAWING	SCALE: 10:1 SHEET 2 OF 4 REV B

REVISIONS				
P.	LTN.	DESCRIPTION	DATE	APVD.
-	-	SEE SHEET 1	-	-

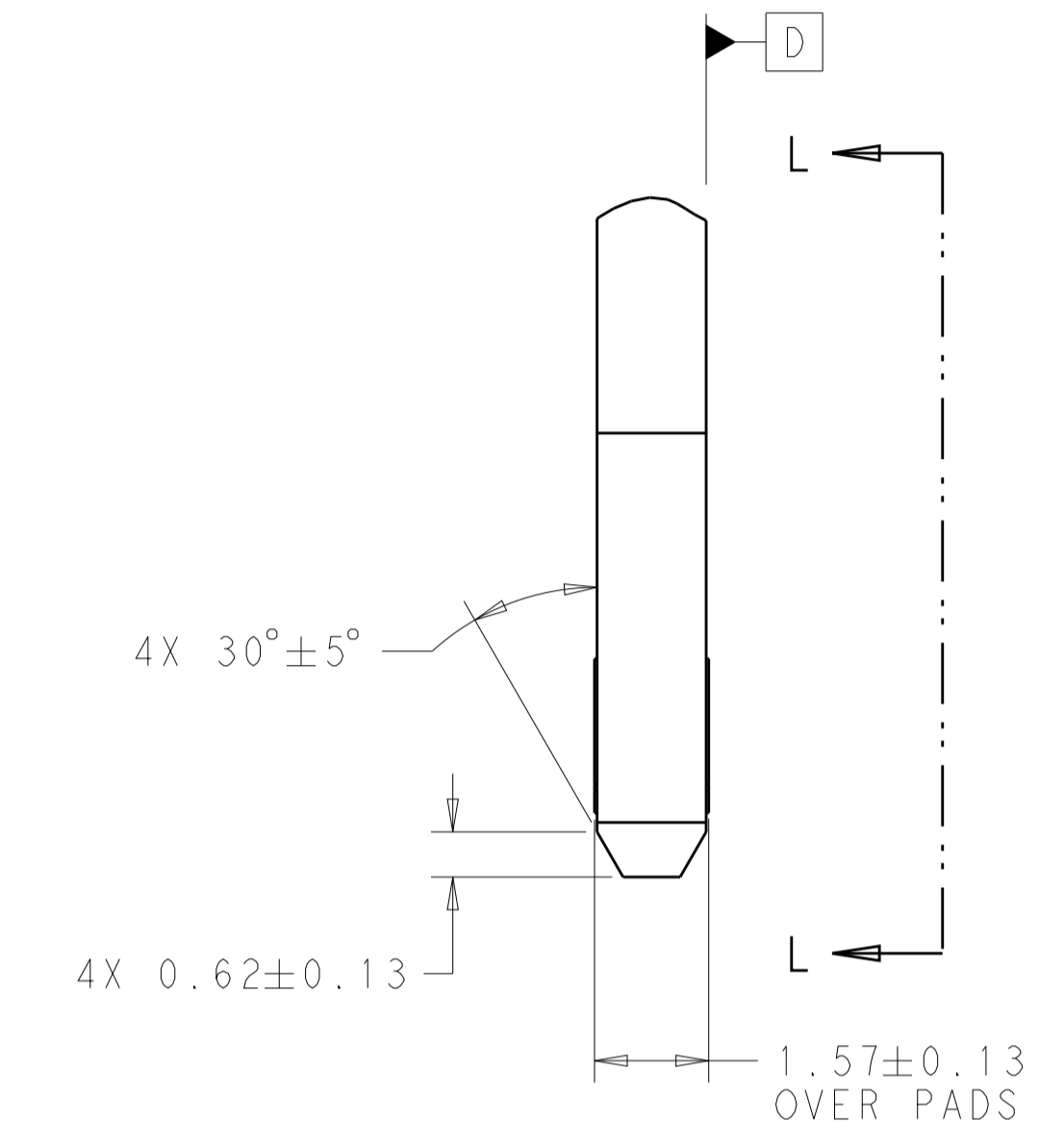
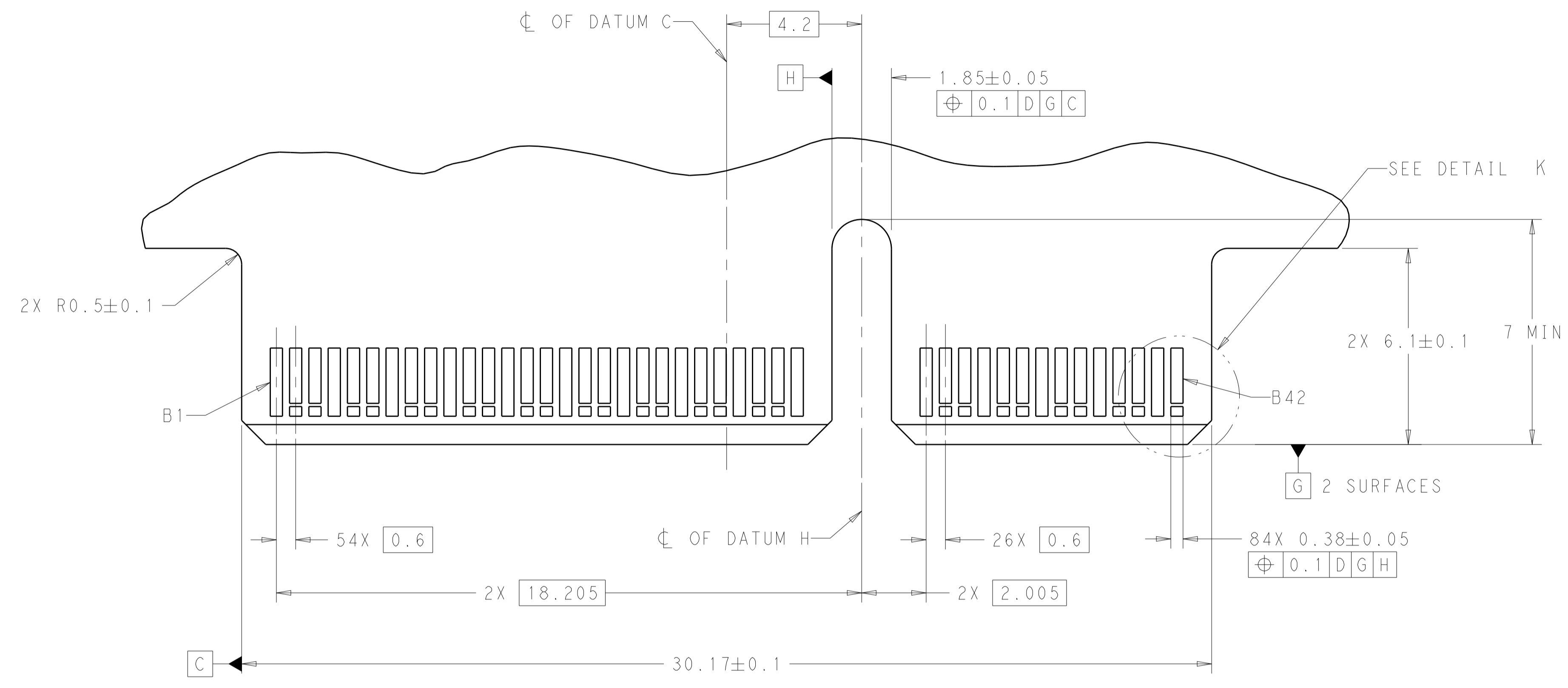

RECOMMENDED PCB OUTLINE DIMENSIONS:
 TOLERANCE VALUES ARE CRITICAL. PLEASE BE SURE TO DESIGNATE
 TOLERANCES TO PCB SUPPLIER TO ENSURE OPTIMIZED FUNCTIONALITY.

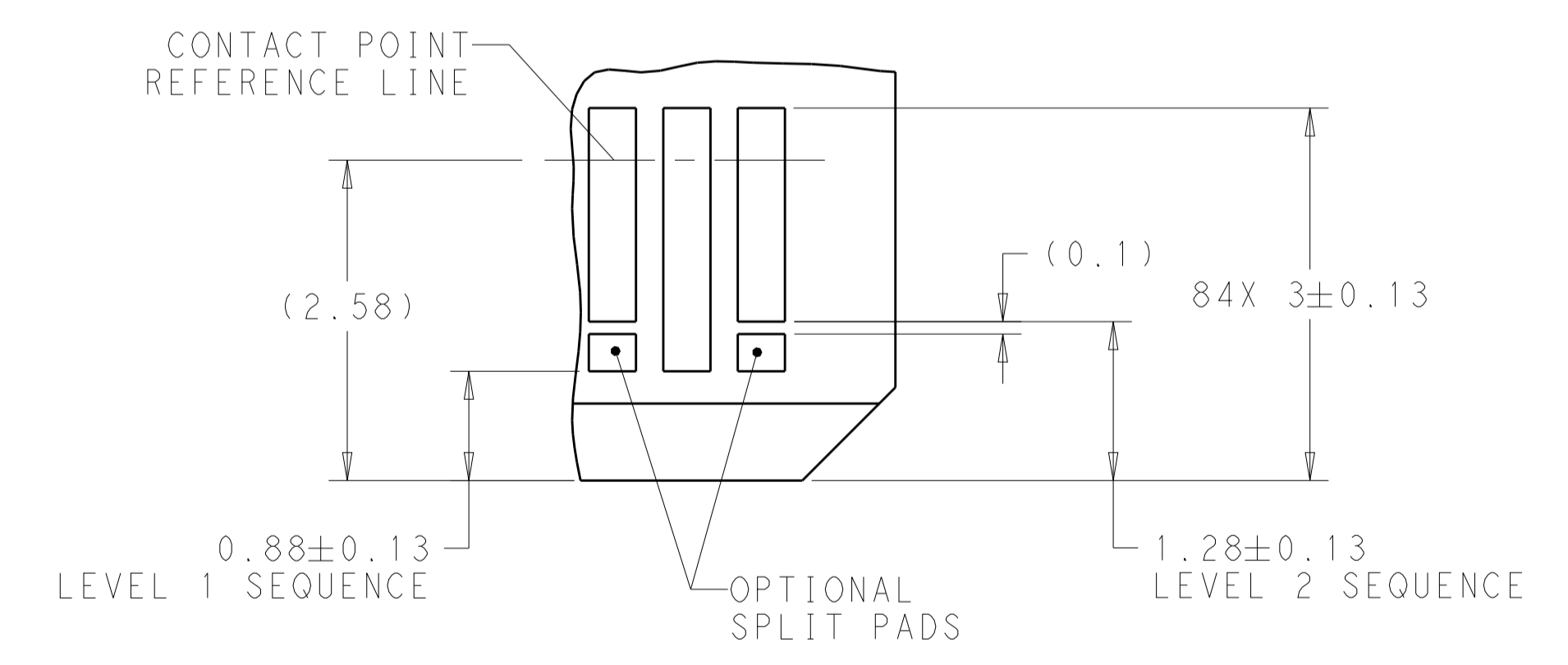

DETAIL K
 SCALE 20:1

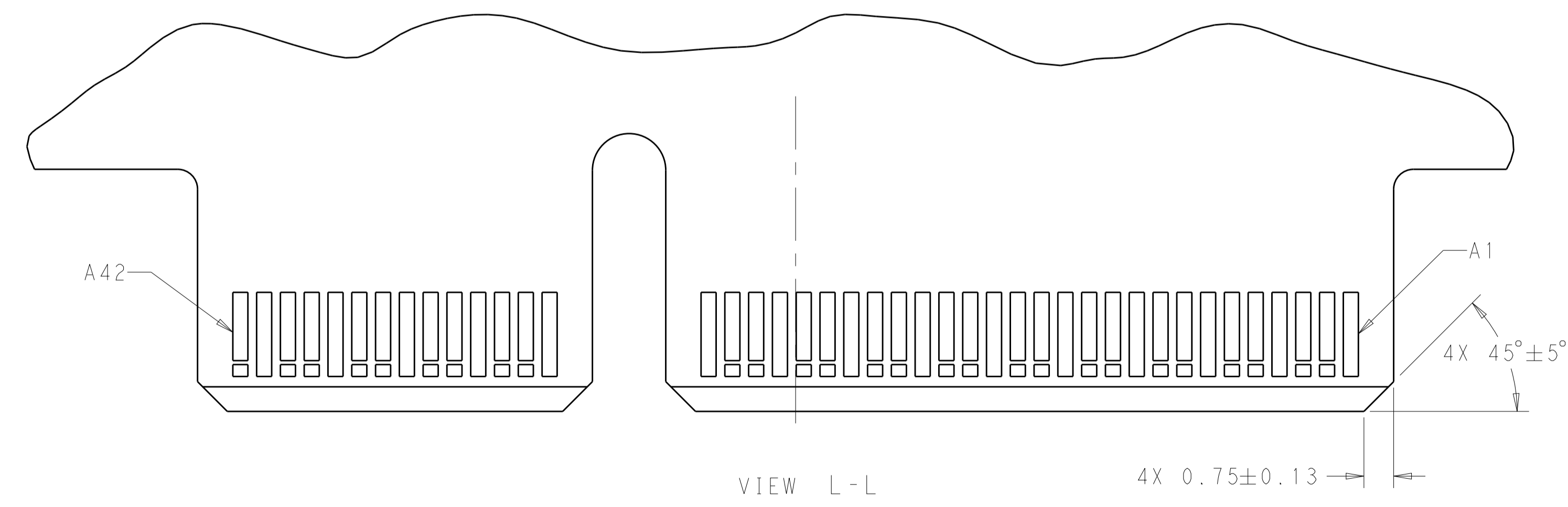

VIEW L-L

THIS DRAWING IS A CONTROLLED DOCUMENT.		DWN: M. SHIRK 22FEB2018	TE Connectivity
DIMENSIONS:		CHK: D. HARMON 22FEB2018	
mm	0 PLC ±	APVD: D. HARMON 22FEB2018	NAME: RECEPTACLE ASSEMBLY, RIGHT ANGLE, 84 POSITION, SILVER 2.0
	1 PLC ±	PRODUCT SPEC: 108-130021	SIZE: A1
	2 PLC ±	APPLICATION SPEC: 114-130008	CAGE CODE: -
MATERIAL:	3 PLC ±	WEIGHT: -	SCALE: 10:1
FINISH:	4 PLC ±	CUSTOMER DRAWING	SHEET 3 OF 4
ANGLES:	±		REV B

REVISIONS				
P.	LTN	DESCRIPTION	DATE	APVD
-	-	SEE SHEET 1	-	-

TABLE 1: CONNECTOR CONTACT IDENTIFICATION \triangle

CONTACT NUMBER	SIDE A	SIDE B
1	GROUND	GROUND
2	SIGNAL	SIGNAL
3	SIGNAL	SIGNAL
4	GROUND	GROUND
5	SIGNAL	SIGNAL
6	SIGNAL	SIGNAL
7	GROUND	GROUND
8	SIGNAL	SIGNAL
9	SIGNAL	SIGNAL
10	GROUND	GROUND
11	SIGNAL	SIGNAL
12	SIGNAL	SIGNAL
13	GROUND	GROUND
14	SIGNAL	SIGNAL
15	SIGNAL	SIGNAL
16	GROUND	GROUND
17	SIGNAL	SIGNAL
18	SIGNAL	SIGNAL
19	GROUND	GROUND
20	SIGNAL	SIGNAL
21	SIGNAL	SIGNAL
22	GROUND	GROUND
23	SIGNAL	SIGNAL
24	SIGNAL	SIGNAL
25	GROUND	GROUND
26	SIGNAL	SIGNAL
27	SIGNAL	SIGNAL
28	GROUND	GROUND
29	GROUND	GROUND
30	SIGNAL	SIGNAL
31	SIGNAL	SIGNAL
32	GROUND	GROUND
33	SIGNAL	SIGNAL
34	SIGNAL	SIGNAL
35	GROUND	GROUND
36	SIGNAL	SIGNAL
37	SIGNAL	SIGNAL
38	GROUND	GROUND
39	SIGNAL	SIGNAL
40	SIGNAL	SIGNAL
41	GROUND	GROUND
42	GROUND	GROUND

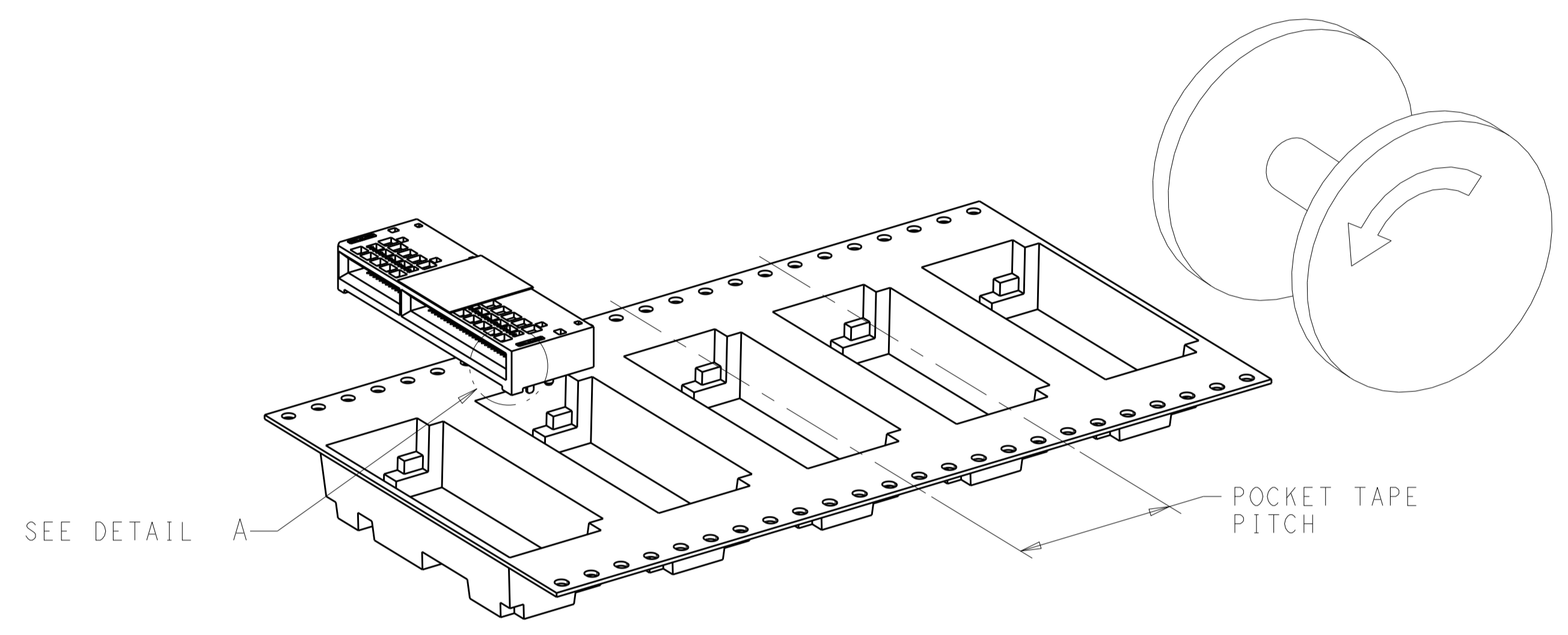
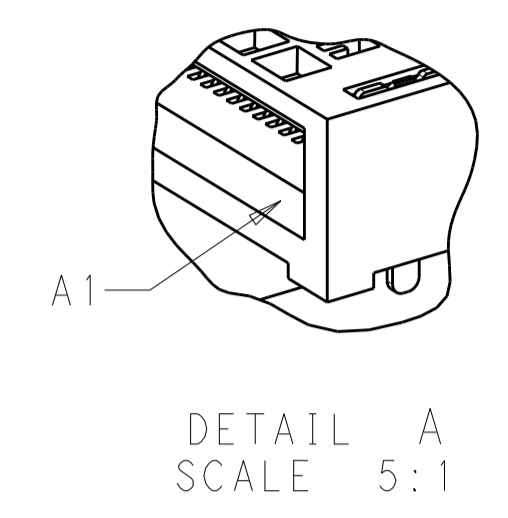

FIGURE 1 \triangle
 DIRECTION OFF TOP OF REEL
 FOR USER UNREELING
 SHOWN AS 2327671-1 THRU 2327671-6
 SCALE 2:1

ENDS	PLATING	POCKET TAPE PITCH	REEL QUANTITY	PICK AND PLACE TAPE	MATING CYCLES	PART NUMBER
ENDS 0.76 μ m Au	PLATING	24	400	NO	200	1-2327671-6
ENDS 0.38 μ m Au						100
ENDS FLASH Au/PdNi	PLATING	24	400	NO	200	1-2327671-4
ALL 0.76 μ m Au						100
ALL 0.38 μ m Au	PLATING	20	500	YES	200	2327671-6
ALL FLASH Au/PdNi						100
ENDS 0.76 μ m Au	PLATING	20	500	YES	200	2327671-3
ENDS 0.38 μ m Au						100
ENDS FLASH Au/PdNi	PLATING	20	500	YES	200	2327671-1
ALL 0.76 μ m Au						100
ALL 0.38 μ m Au	PLATING	POCKET TAPE PITCH	REEL QUANTITY	PICK AND PLACE TAPE	MATING CYCLES	PART NUMBER

THIS DRAWING IS A CONTROLLED DOCUMENT.

DIMENSIONS:	TOLERANCES UNLESS OTHERWISE SPECIFIED:	OWN: M. SHIRK 22FEB2018	TE Connectivity RECEPTACLE ASSEMBLY, RIGHT ANGLE, 84 POSITION, SILVER 2.0
mm	0 PLC \pm	CHK: D. HARMON 22FEB2018	
	2 PLC \pm	APVD: D. HARMON 22FEB2018	
	4 PLC \pm	PRODUCT SPEC: 108-130021	
MATERIAL:	FINISH:	APPLICATION SPEC: 114-130008	RESTRICTED TO:
		WEIGHT:	SIZE: A1
		CUSTOMER DRAWING	SCALE: 10:1

SHEET 4 OF 4 REV B