

THIS DRAWING IS UNPUBLISHED. RELEASED FOR PUBLICATION  
 © COPYRIGHT - By - ALL RIGHTS RESERVED.

REVISIONS					
P	LTR	DESCRIPTION	DATE	DWN	APVD
	L	REV PER ECR 09-013993	19JUN09	JR	TM
	L1	REVISED PER ECO-16-017419	14MAR2017	RS	DR

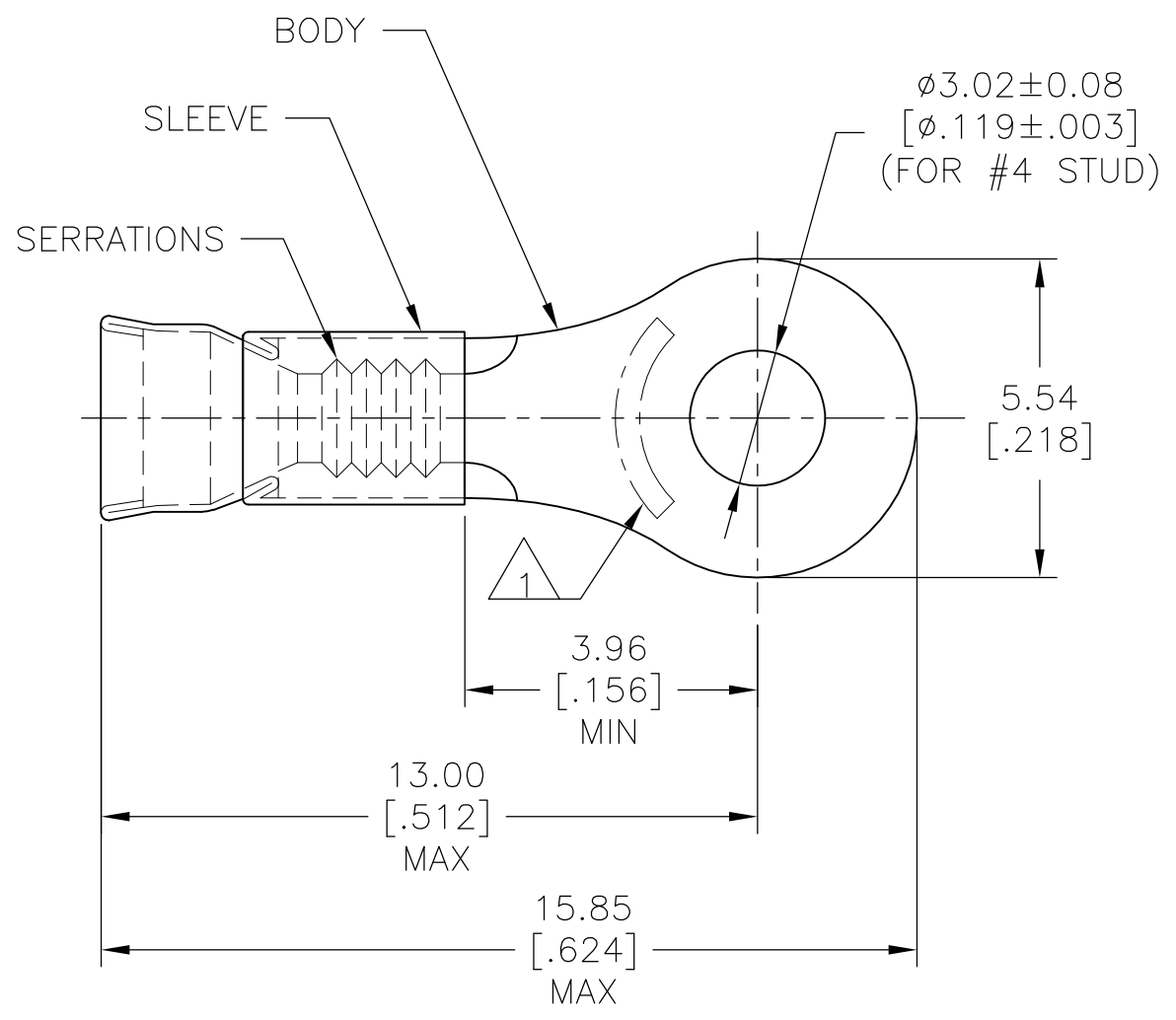

- 1 STAMP AMP 22-18\* APPROX AS SHOWN  
22-16 TERMINALS ARE STAMPED 22-18 IN  
ACCORDANCE WITH MILITARY SPEC MIL-T-7928  
COMMERCIAL WIRE RANGE IS 22-16.
- 2 WIRE INSUL DIA,  $\phi 2.67-3.56$  [ $\phi .105-.140$ ].
- 3 TONGUE MATL THK,  $0.79 \pm 0.05$  [ $.031 \pm .002$ ].
- 4 BODY, NICKEL-PLATE PER QQ-N-290.
- 5 BODY, GOLD-PLATE WITH NICKEL UNDERPLATE  
PER ASTM B-488.
- 6 MATERIAL: BODY - CU PER ASTM B152  
SLEEVE - NI SILVER PER ASTM B122.
- 7 NOTE DELETED.
- 8 NOTE DELETED.

260°C	5	6	1000	LOOSE PIECE	322363-1
343°C	4	6	1000	LOOSE PIECE	322363
MAX TEMP	FINISH	MATERIAL	QTY	PACKAGE TYPE	PART NO

AMP INCORPORATED CUSTOMER SERVICE SYSTEMS		MAX RECOMMENDED OPERATING TEMPERATURE: SEE CHART	THIS DRAWING IS A CONTROLLED DOCUMENT.		DWN L OLMEDA 10OCT94	TE Connectivity				
FOR ADDITIONAL PRODUCT INFORMATION OR COPIES OF DRAWINGS AND TECHNICAL DOCUMENTS	PRODUCT INFORMATION CENTER 1-800-522-6752	VOLTAGE RATING: -	DIMENSIONS: mm [INCHES]	TOLERANCES UNLESS OTHERWISE SPECIFIED:	CHK M ELLIS 10OCT94					NAME
FOR APPLICATION TOOLING INFORMATION	TOOLING ASSISTANCE CENTER 1-800-722-1111	CIRCULAR MIL AREA: 0.26-1.65mm <sup>2</sup> [509-3260] STRANDED		0 PLC ± - 1 PLC ± - 2 PLC ± 0.20 [.008] 3 PLC ± - 4 PLC ± - ANGLES ± -	APVD S BORTNER 10OCT94	TERMINAL, RING TONGUE, STRATOTHERM, DIAMOND GRIP, WIRE SIZE: 22-16 AWG				
FOR ORDER ENTRY	1-800-526-5142	THIS DRAWING IS A CONTROLLED DOCUMENT FOR AMP INCORPORATED. IT IS SUBJECT TO CHANGE AND THE CONTROLLING ENGINEERING ORGANIZATION SHOULD BE CONTACTED FOR THE LATEST REVISION.		MATERIAL SEE TABLE	FINISH SEE TABLE	PRODUCT SPEC -	SIZE A3	CAGE CODE 00779	DRAWING NO C-322363	RESTRICTED TO -
					CUSTOMER DRAWING	SCALE 6:1	SHEET 1 OF 1	REV L1		