

THIS DRAWING IS UNPUBLISHED. RELEASED FOR PUBLICATION
 © COPYRIGHT - By - ALL RIGHTS RESERVED.

LOC	DIST	REVISIONS					
		P	LTR	DESCRIPTION	DATE	DWN	APVD
G	14		F3	REVISED PER ECO-15-002268	17FEB2015	NK	DR

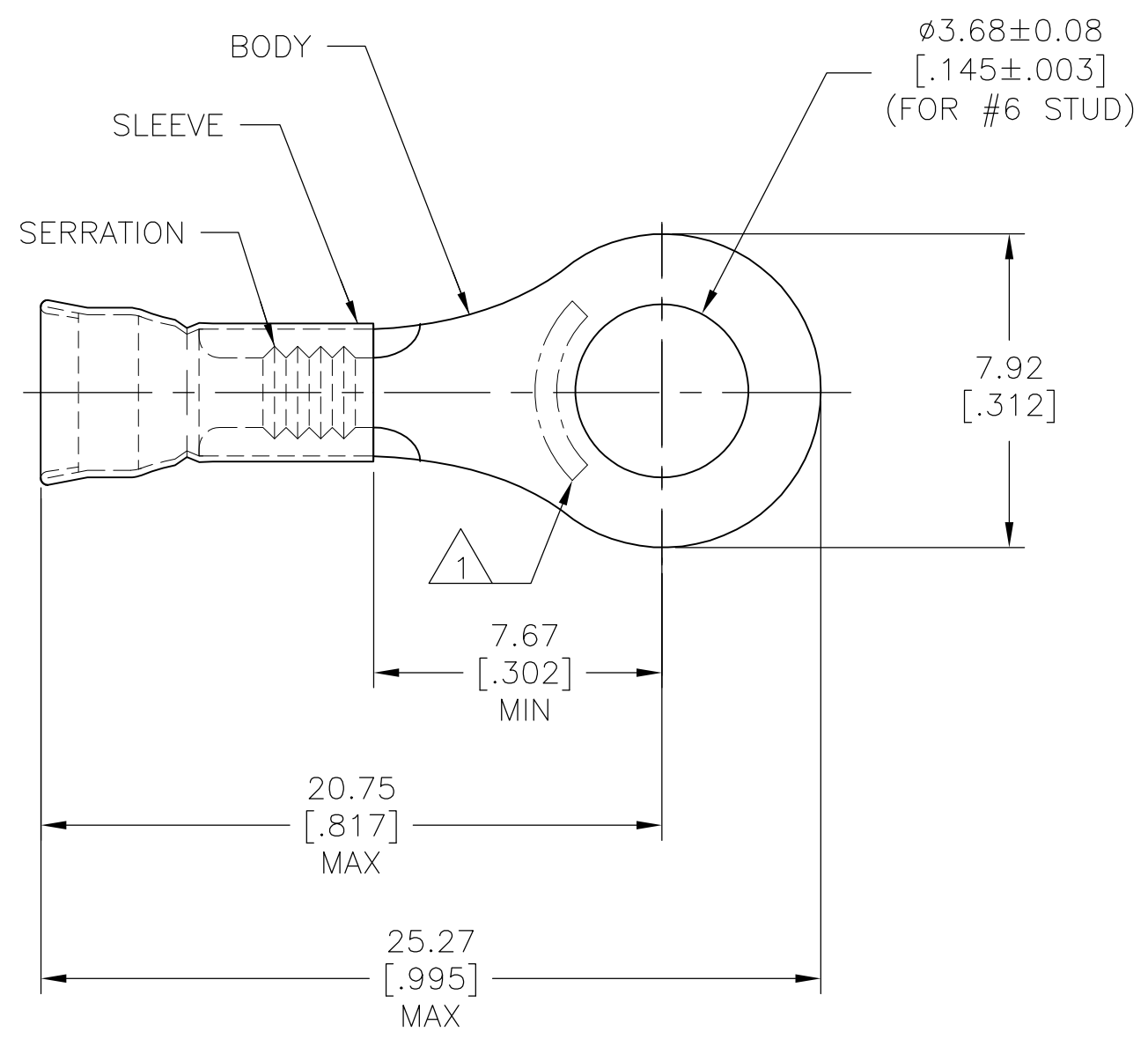

AMP WIRE RANGE	E13288	LR7189 Certified
12-10 AWG SOLID OR STRANDED	12-10 AWG SOLID OR STRANDED	12-10 AWG SOLID OR STRANDED

- 1 STAMP AMP 12-10* LOCATE APPROX AS SHOWN.
- 2 WIRE INSUL DIA 3.81-5.84[.150-.230].
- 3 TONGUE MATL THK. 1.02±0.05[.040±.002].

2500	ON TAPE & REEL	2-326889-1
500	LOOSE PIECE	326889
QTY	PACKAGE TYPE	PART NO

AMP INCORPORATED CUSTOMER SERVICE SYSTEMS		MAX RECOMMENDED OPERATING TEMPERATURE: 170°C[338°F]	THIS DRAWING IS A CONTROLLED DOCUMENT.		DWN L OLMEDA 23JAN95	TE Connectivity	
FOR ADDITIONAL PRODUCT INFORMATION OR COPIES OF DRAWINGS AND TECHNICAL DOCUMENTS	PRODUCT INFORMATION CENTER 1-800-522-6752	VOLTAGE RATING: -	DIMENSIONS: mm [INCHES]	TOLERANCES UNLESS OTHERWISE SPECIFIED: 0 PLC ± - 1 PLC ± - 2 PLC ± 0.20[.008] 3 PLC ± - 4 PLC ± - ANGLES ± -	CHK M ELLIS 23JAN95		NAME TERMINAL, RING, DIAMOND GRIP, WIRE SIZE, 12-10 AWG
FOR APPLICATION TOOLING INFORMATION	TOOLING ASSISTANCE CENTER 1-800-722-1111	CIRCULAR MIL AREA: 2.62mm ² -6.64mm ² [5180-13100]		FINISH TIN PLATE PER MIL-T-10727	APVD S BORTNER 23JAN95		
FOR ORDER ENTRY	1-800-526-5142	MATERIAL BODY, CU, SLV, CU PER ASTM B152	MATERIAL		PRODUCT SPEC UL486A		CAGE CODE 00779
			MATERIAL		APPLICATION SPEC -	DRAWING NO C-326889	
			MATERIAL		WEIGHT -	RESTRICTED TO -	
			MATERIAL		SCALE 6:1		
			MATERIAL		SHEET 1 OF 1		
			MATERIAL		REV F3		
			MATERIAL		CUSTOMER DRAWING		