

REVISIONS								
LOC	DIST	P	F	ZONE	LTR	DESCRIPTION	DATE	APPD
G	14				A	REVISED PER 0720-0170-93	11/23/93	CHK

METRIC
 DIMENSIONS LISTED IN mm [INCHES]

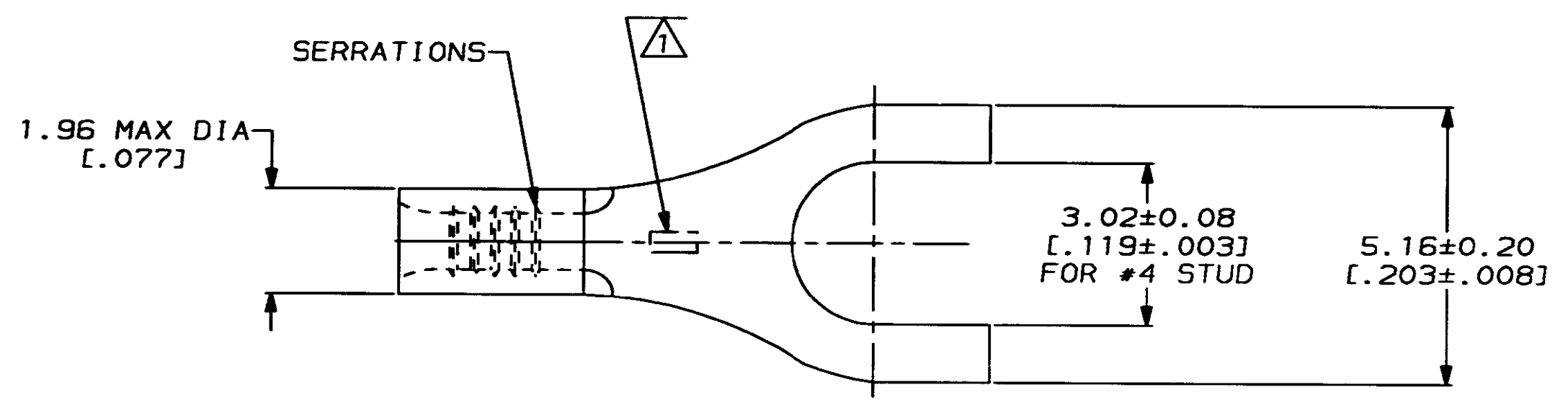

AMP WIRE RANGE	UL E13288 Listed
26-22 AWG STRANDED	NOT LISTED
LR7189 Certified	MILITARY P/N AND CLASS
NOT CERTIFIED	NOT APPLICABLE

1 STAMP AMP APPROX AS SHOWN

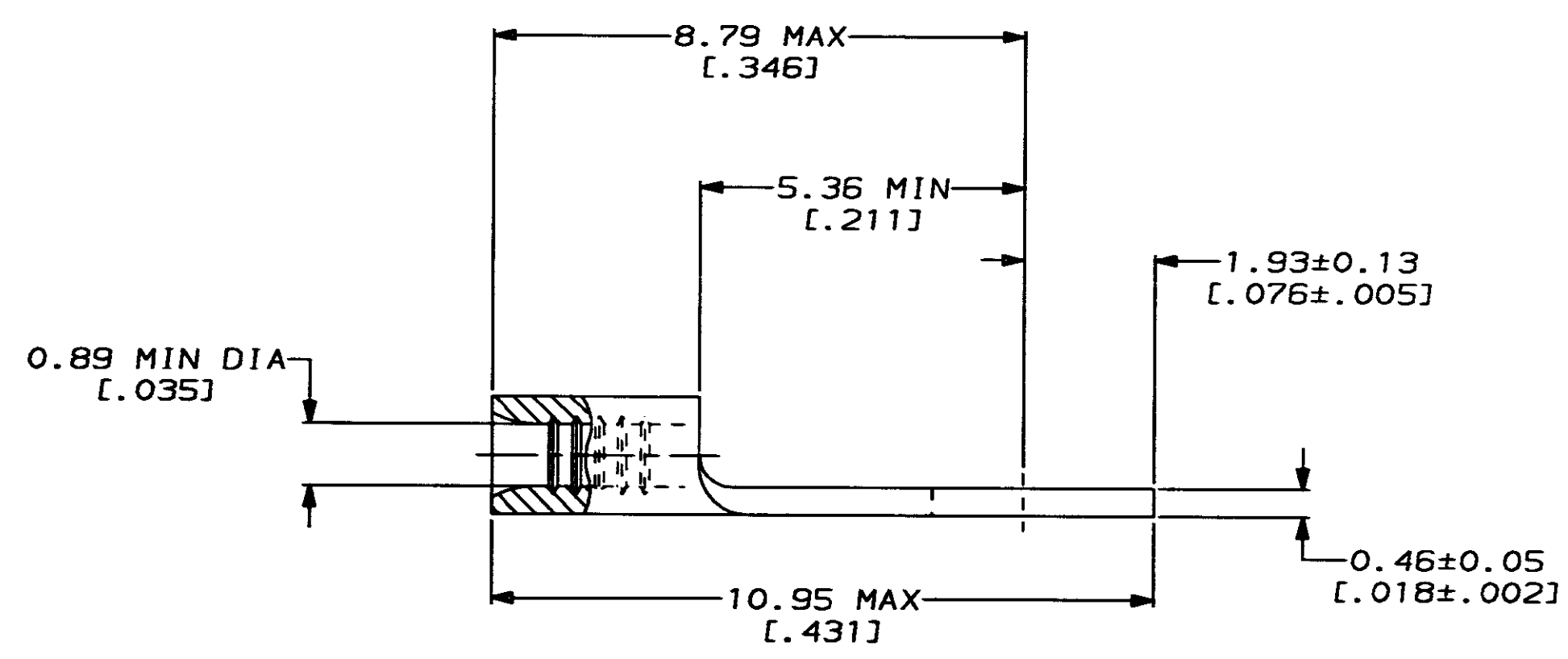

AMP INCORPORATED CUSTOMER SERVICE SYSTEMS		MAX RECOMMENDED OPERATING TEMPERATURE: 170°C MAX	DO NOT SCALE PRINT. UNLESS SPECIFIED DIMENSIONS IN mm [INCHES] TOLERANCES ON: 2 PLC DEC ± - 3 PLC DEC ± - ANGLES ± -	DR 2-16-93 TA BRINKMAN	AMP AMP Incorporated Harrisburg, PA 17105-3608	
FOR ADDITIONAL PRODUCT INFORMATION OR COPIES OF DRAWINGS AND TECHNICAL DOCUMENTS	PRODUCT INFORMATION CENTER 1-800-522-6752	VOLTAGE RATING: NCT APPLICABLE	MATERIAL COPPER PER ASTM B-152 ANNEALED	CHK 2-16-93 DA PATTERSON	NAME TERMINAL, SPADE TONGUE, BUDGET	
FOR APPLICATION TOOLING INFORMATION	TOOLING ASSISTANCE CENTER 1-800-722-1111	WIRE CROSS SECTIONAL AREA RANGE: 0.1-0.41mm ² [202-810] CIR MILS STRANDED	FINISH TIN PLATE 0.00254[.000100] MIN THK PER MIL-T-10727	APPD 2-16-93 DE MILLER		
FOR ORDER ENTRY	1-800-526-5142	THIS DRAWING IS A CONTROLLED DOCUMENT FOR AMP INCORPORATED. IT IS SUBJECT TO CHANGE AND THE CONTROLLING ENGINEERING ORGANIZATION SHOULD BE CONTACTED FOR THE LATEST REVISION.		APPD 2-16-93 JL MECKLEY	PRODUCT SPEC -	SIZE C 00779
				APPLICATION SPEC -		DRAWING NO C-34247
				WEIGHT -	SCALE 10:1	SHEET 1 OF 1