

THIS DRAWING IS UNPUBLISHED. RELEASED FOR PUBLICATION  
 © COPYRIGHT 19 BY AMP INCORPORATED. ALL INTERNATIONAL RIGHTS RESERVED.

LOC	DIST	P	F	ZONE	LTR	DESCRIPTION	DATE	APPD
G	14				G	REL PER 0G3A-0075-01	28JAN01	JR/MS

**METRIC**  
 DIMENSIONS LISTED IN mm [ INCHES ]

<b>AMP</b> WIRE RANGE	<b>UL</b> E13288 Listed
12-10 AWG SOLID OR STRANDED	12-10 AWG STRANDED PN 36270 ONLY
<b>CS</b> LR7189 Certified	<b>MILITARY P/N</b> AND CLASS
12-10 AWG SOLID OR STRANDED PN 36270 ONLY	NOT APPLICABLE

△ STAMP AMP 12-10\* APPROX AS SHOWN

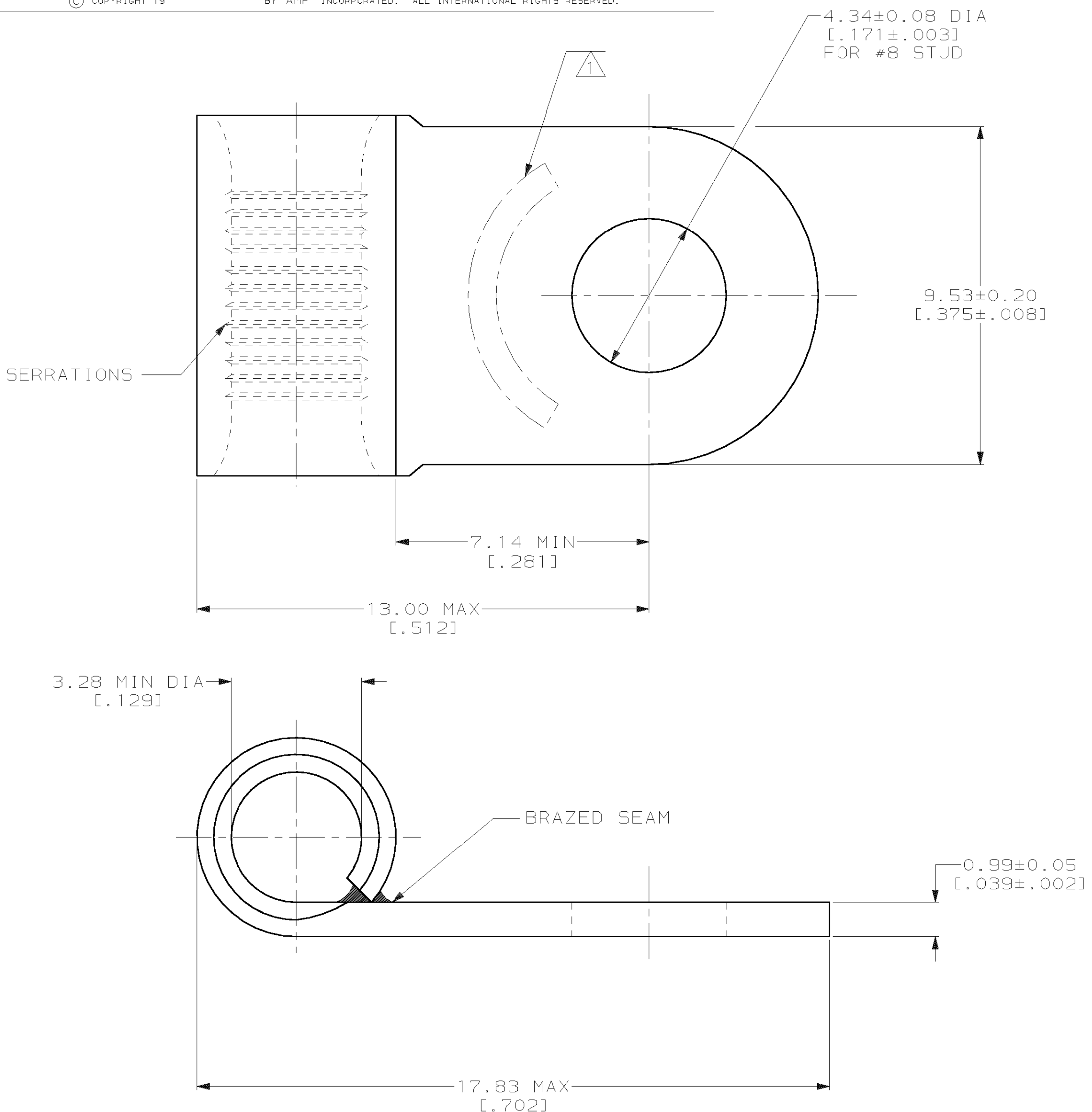

343°C	NICKEL PLATE 0.00762[.000300] MIN THK PER QQ-N-290	1-36270-1
170°C	TIN PLATE 0.00254[.000100] MIN THK PER ASTM B 545	36270
MAX OPERATING TEMPERATURE	FINISH	PART NO

**AMP INCORPORATED**  
**CUSTOMER SERVICE SYSTEMS**

FOR ADDITIONAL PRODUCT INFORMATION OR COPIES OF DRAWINGS AND TECHNICAL DOCUMENTS  
 PRODUCT INFORMATION CENTER  
 1-800-522-6752

FOR APPLICATION TOOLING INFORMATION  
 TOOLING ASSISTANCE CENTER  
 1-800-722-1111

FOR ORDER ENTRY  
 1-800-526-5142

MAX RECOMMENDED OPERATING TEMPERATURE:  
 SEE TABLE

VOLTAGE RATING:  
 NOT APPLICABLE

WIRE CROSS SECTIONAL AREA RANGE:  
 2.62-6.64mm<sup>2</sup> [5,180-13,100] CIR MILS  
 SOLID OR STRANDED

THIS DRAWING IS A CONTROLLED DOCUMENT FOR AMP INCORPORATED. IT IS SUBJECT TO CHANGE AND THE CONTROLLING ENGINEERING ORGANIZATION SHOULD BE CONTACTED FOR THE LATEST REVISION.

DO NOT SCALE PRINT. UNLESS SPECIFIED DIMENSIONS IN mm [INCHES]— TOLERANCES ON :  
 2 PLC DEC ± -  
 3 PLC DEC ± -  
 ANGLES ± -

MATERIAL  
 COPPER PER ASTM B-152 ANNEALED

FINISH  
 SEE TABLE

DR 4-5-93  
 TA BRINKMAN

CHK 4-5-93  
 DA PATTERSON

APPD 4-5-93  
 DE MILLER

APPD 4-5-93  
 JL MECKLEY

PRODUCT SPEC  
 -

APPLICATION SPEC  
 -

WEIGHT  
 -

**AMP** AMP Incorporated  
 Harrisburg, PA 17105-3608

NAME  
**TERMINAL, RING TONGUE, FLAG, SOLISTRAND™**

SIZE **C** CAGE CODE **00779** DRAWING NO **C-36270**

SCALE 10:1 SHEET 1 OF 1