

LOC	DIST	REVISIONS		
AJ	16	P	LTR	DESCRIPTION
				DATE
				DWN
				APVD
		E1	REVISED PER ECO-06-018711	30AUG2000
				MC
				JH

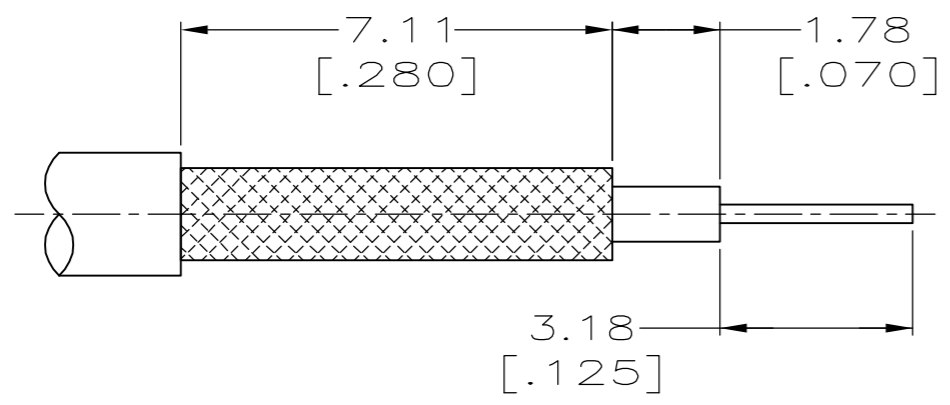

RECOMMENDED STRIP LENGTHS

1. PARTS PACKAGED UNASSEMBLED.
2. CONTACT CRIMP: CRIMP TOOL MIL-C-22520/5-01 WITH DANIELS POSITIONER K727; SET ON POSITION #2.
3. BRAID CRIMP: AMP HAND TOOL PART NUMBER 220190-1 WITH DIE SET PART NUMBER 58046-1, OR HAND TOOL MIL-C-22520/5-01 WITH DANIELS DIE SET NUMBER Y144.
4. BRAID CRIMP: AMP HAND TOOL PART NUMBER 220190-1 WITH DIE SET PART NUMBER 59969-2, OR HAND TOOL MIL-C-25520/5-01 WITH DANIELS DIE SET NUMBER Y196.

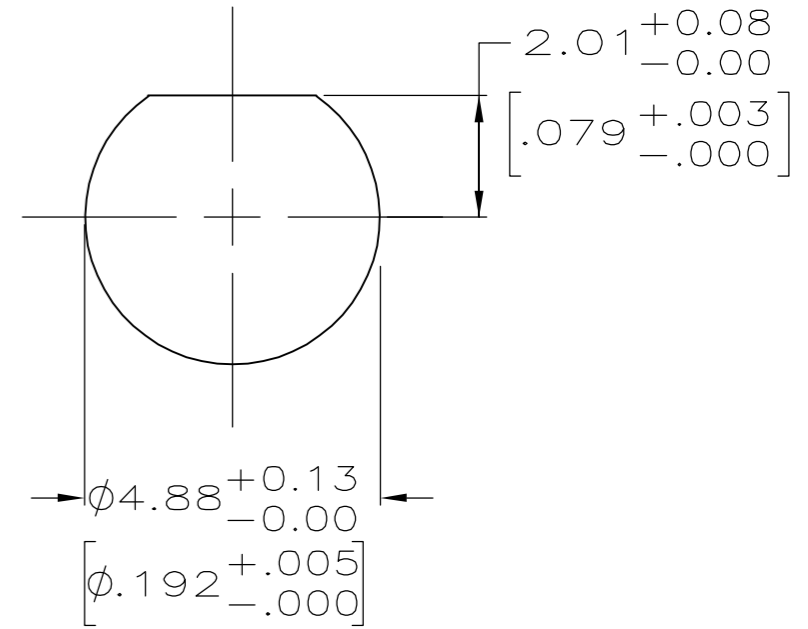
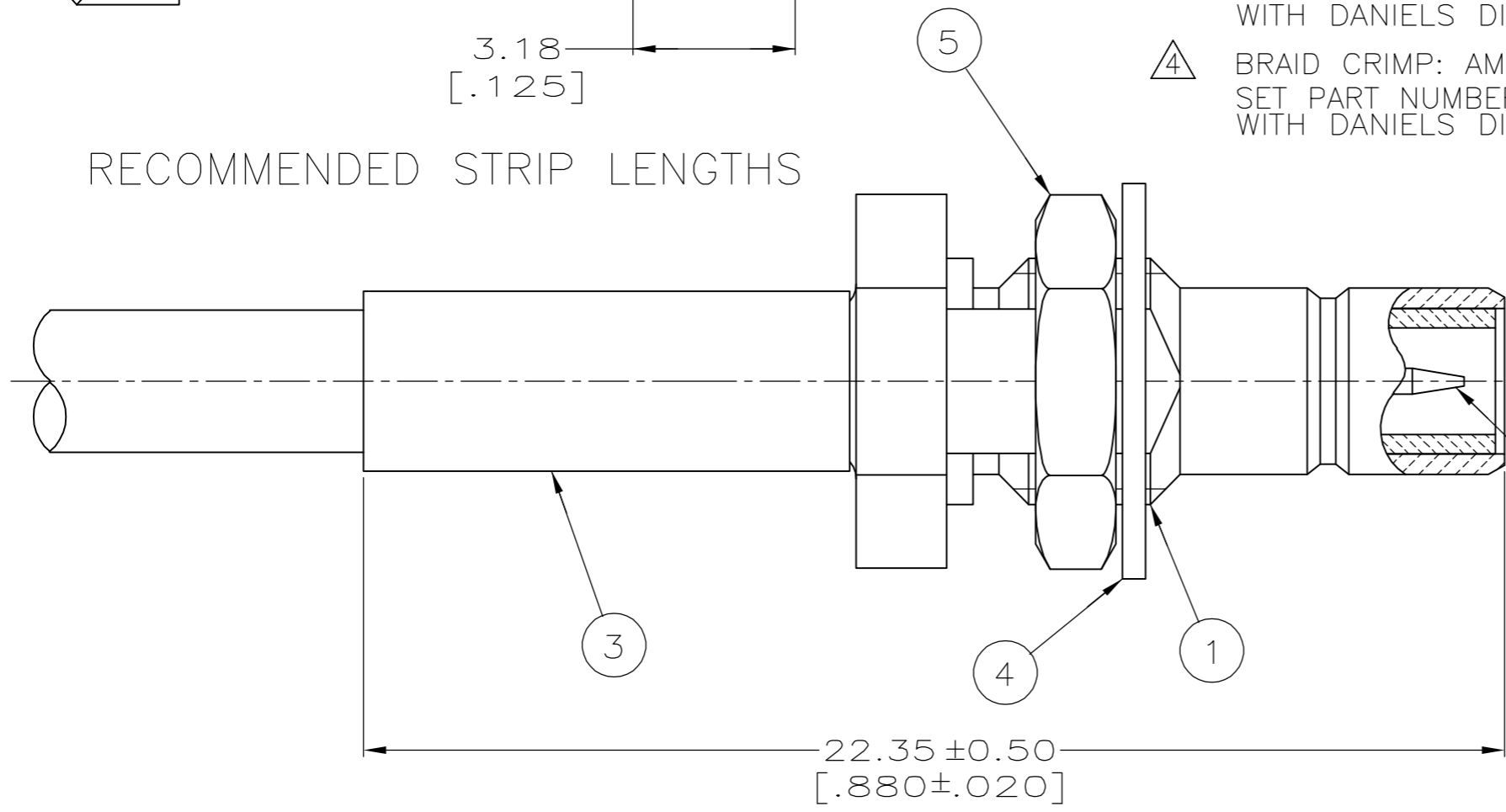

RECOMMENDED PANEL CUT-OUT

OBSOLETE	RG-178/U	2 3	414969-2	415001-2	1-413889-3	228570-2	415007-1	415006-3
OBSOLETE	RD-316	2 4	414969-2	415001-2	1-413889-4	228225-2	415007-1	415006-2
	RG-188/U & -316/U	2 3	414969-2	415001-2	1-413889-3	228225-2	415007-1	415006-1
	CABLE	CRIMP TOOLING	5 JAM NUT QTY=1	4 LOCKWASHER QTY=1	3 FERRULE QTY=1	2 CONTACT QTY=1	1 JACK ASSY QTY=1	PART NUMBER

THIS DRAWING IS A CONTROLLED DOCUMENT.

DWN B. MOYER 16SEP96
 CHK J. CABARLO 17SEP96
 APVD J. CABARLO 17SEP96

AMP AMP Incorporated
 Harrisburg, PA 17105-3608

DIMENSIONS: mm [INCHES] TOLERANCES UNLESS OTHERWISE SPECIFIED:
 0 PLC ±-
 1 PLC ±-
 2 PLC ±0.25 [.010]
 3 PLC ±-
 4 PLC ±-
 ANGLES ±-
 MATERIAL - FINISH -

PRODUCT SPEC -
 APPLICATION SPEC -
 WEIGHT -

BULKHEAD JACK, SMB

SIZE A3 CAGE CODE 00779 DRAWING NO C-415006
 CUSTOMER DRAWING SCALE 8:1 SHEET 1 OF 1 REV E1