

THIS DRAWING IS UNPUBLISHED. RELEASED FOR PUBLICATION 20
 © COPYRIGHT 20 BY - ALL RIGHTS RESERVED.

REVISIONS					
P	LTR	DESCRIPTION	DATE	DWN	APVD
J1		REVISED PER ECR-16-011494	23JUN2017	NK	CX
J2		ECO-19-006502	30APR2019	AP	WS

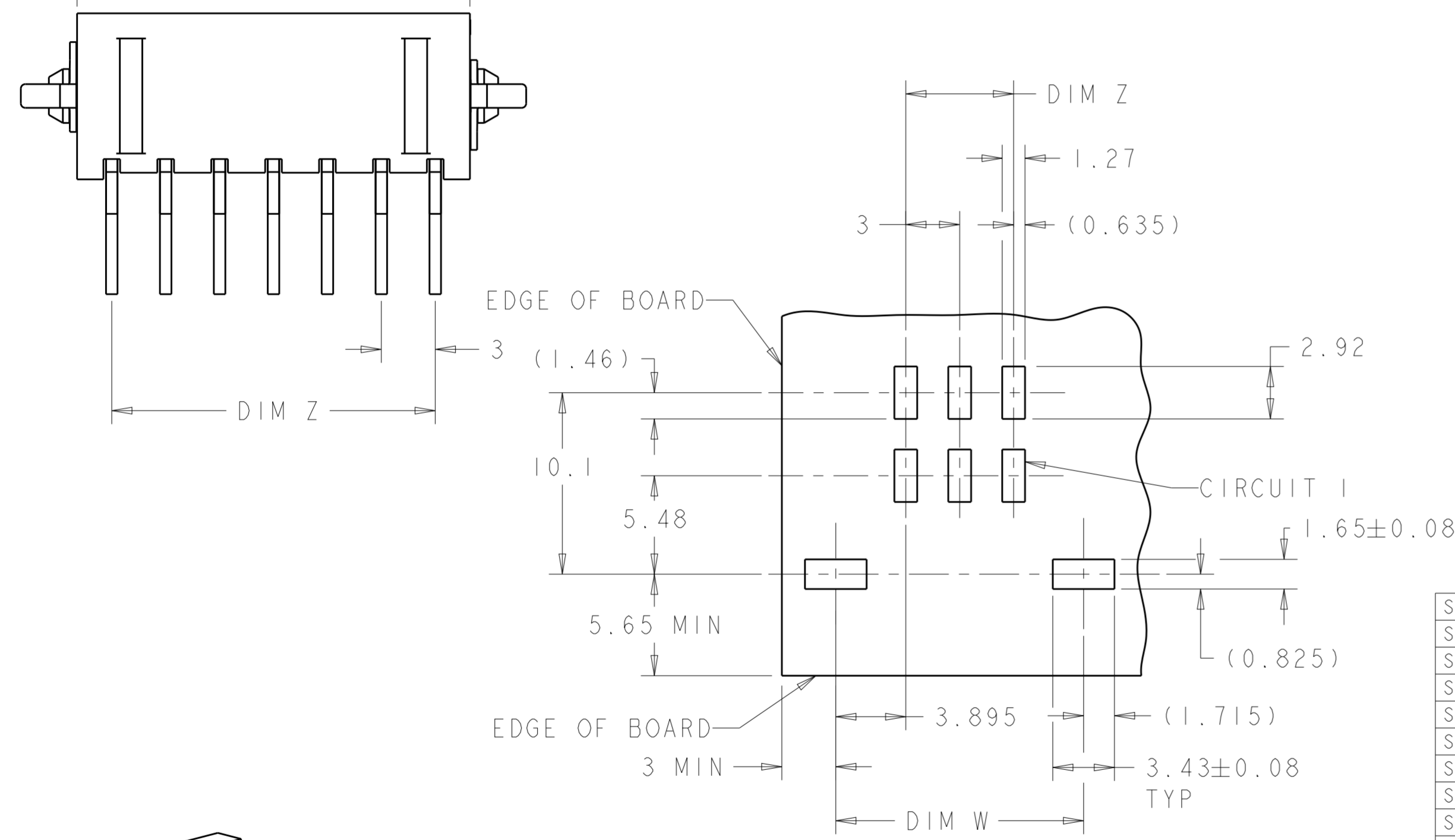
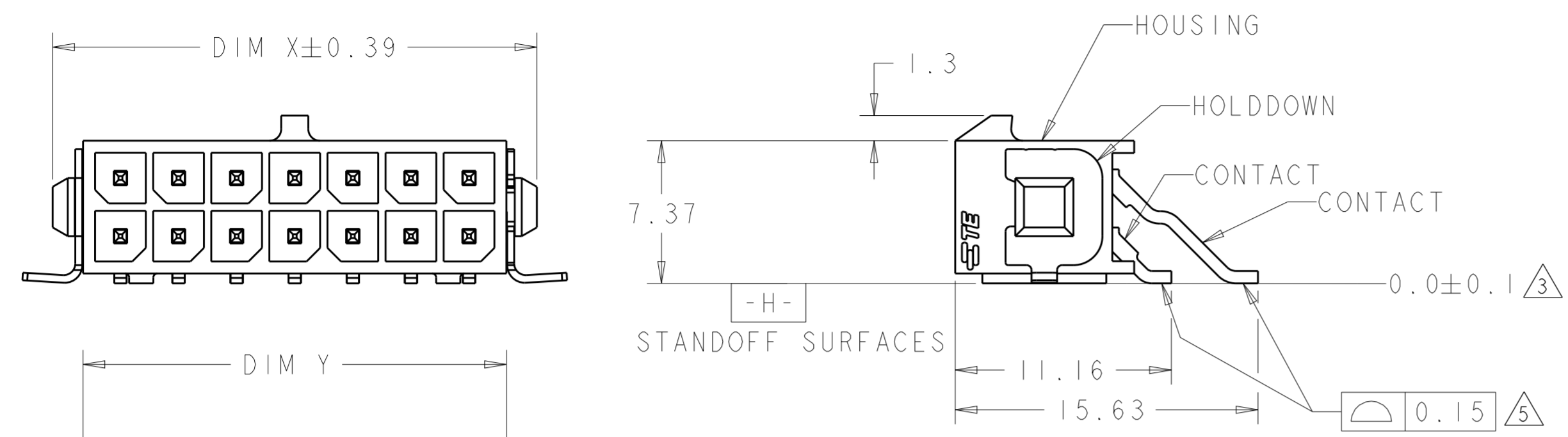

- ① MATERIAL;
 CONTACTS - BRASS.
 HOUSING - UL 94V-0 RATED HIGH TEMP NYLON,
 COLOR; BLACK.
 HOLD DOWNS - PHOSPHOR BRONZE.
- ② FINISH;
 CONTACTS - 2.54µm MINIMUM TIN-LEAD OVER 1.27µm
 MINIMUM NICKEL.
 HOLD DOWNS - 2.54µm TIN-LEAD.
- ③ DIMENSION APPLIES TO SOLDER TAIL SURFACES
 AND STANDOFF SURFACES.
- ④ RECOMMENDED PC BOARD THICKNESS OF 1.57.
- ⑤ ALL SOLDER TAILS AND HOLD DOWNS.
- ⑥ FINISH;
 CONTACTS - 2.54µm MINIMUM MATTE TIN OVER 1.27µm
 MINIMUM NICKEL.
 HOLD DOWNS - 2.54µm MINIMUM MATTE TIN.

⑥	36.86	40.79	33.00	40.00	24	5-794627-4
⑥	33.86	37.79	30.00	37.00	22	5-794627-2
⑥	30.86	34.79	27.00	34.00	20	5-794627-0
⑥	27.86	31.79	24.00	31.00	18	4-794627-8
⑥	24.86	28.79	21.00	28.00	16	4-794627-6
⑥	21.86	25.79	18.00	25.00	14	4-794627-4
⑥	18.86	22.79	15.00	22.00	12	4-794627-2
⑥	15.86	19.79	12.00	19.00	10	4-794627-0
⑥	12.86	16.79	9.00	16.00	8	3-794627-8
⑥	9.86	13.79	6.00	13.00	6	3-794627-6
⑥	6.86	10.79	3.00	10.00	4	3-794627-4
⑥	3.86	7.79	-	7.00	2	3-794627-2
②	36.86	40.79	33.00	40.00	24	2-794627-4
②	33.86	37.79	30.00	37.00	22	2-794627-2
②	30.86	34.79	27.00	34.00	20	2-794627-0
②	27.86	31.79	24.00	31.00	18	1-794627-8
②	24.86	28.79	21.00	28.00	16	1-794627-6
②	21.86	25.79	18.00	25.00	14	1-794627-4
②	18.86	22.79	15.00	22.00	12	1-794627-2
②	15.86	19.79	12.00	19.00	10	1-794627-0
②	12.86	16.79	9.00	16.00	8	794627-8
②	9.86	13.79	6.00	13.00	6	794627-6
②	6.86	10.79	3.00	10.00	4	794627-4
②	3.86	7.79	-	7.00	2	794627-2

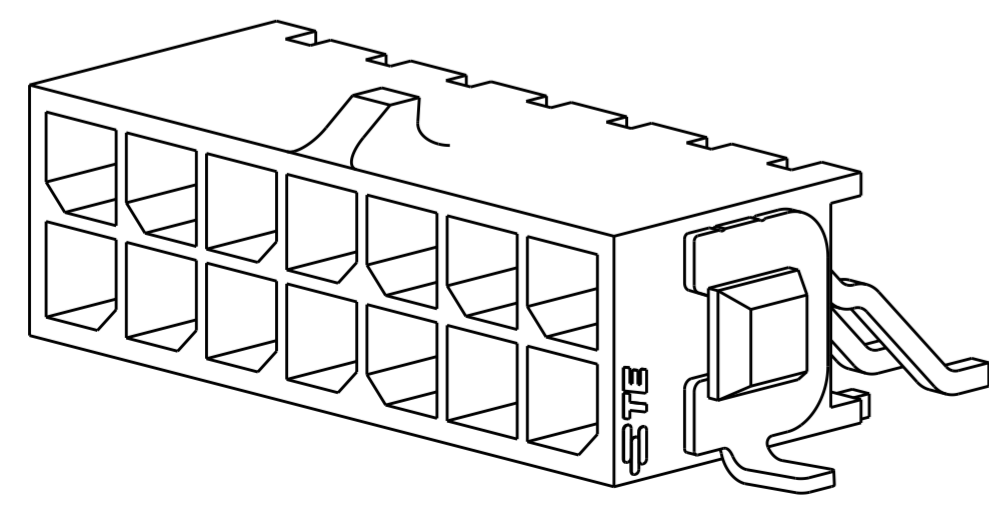

SCALE 5:1

RECOMMENDED PCB LAYOUT ④
 (COMPONENT SIDE)

THIS DRAWING IS A CONTROLLED DOCUMENT. DWN S. HOOVER 23-MAR-2005
 CHK C. JONES 23-MAR-2005
 APVD C. JONES 23-MAR-2005

STC TE Connectivity

NAME SURFACE MOUNT, RIGHT ANGLE, SURFACE MOUNT HOLD DOWN, ASSEMBLY, TIN HEADER, DUAL ROW, MICRO MATE-N-LOK (TM)

PRODUCT SPEC 108-1836
 APPLICATION SPEC 114-13000

SIZE A2 CAGE CODE 00779 DRAWING NO. C-794627
 WEIGHT -

CUSTOMER DRAWING SCALE 4:1 SHEET 1 OF 1 REV J2