

THIS DRAWING IS UNPUBLISHED. RELEASED FOR PUBLICATION  
 © COPYRIGHT - By - ALL RIGHTS RESERVED.

| LOC | DIST | REVISIONS   |                           |           |       |
|-----|------|-------------|---------------------------|-----------|-------|
| P   | LTR  | DESCRIPTION | DATE                      | DWN       | APVD  |
| G   | 14   | F           | REVISED PER ECO-15-001511 | 10FEB2015 | NK DR |

**AMP**  
WIRE RANGE

---

26 AWG  
STRANDED

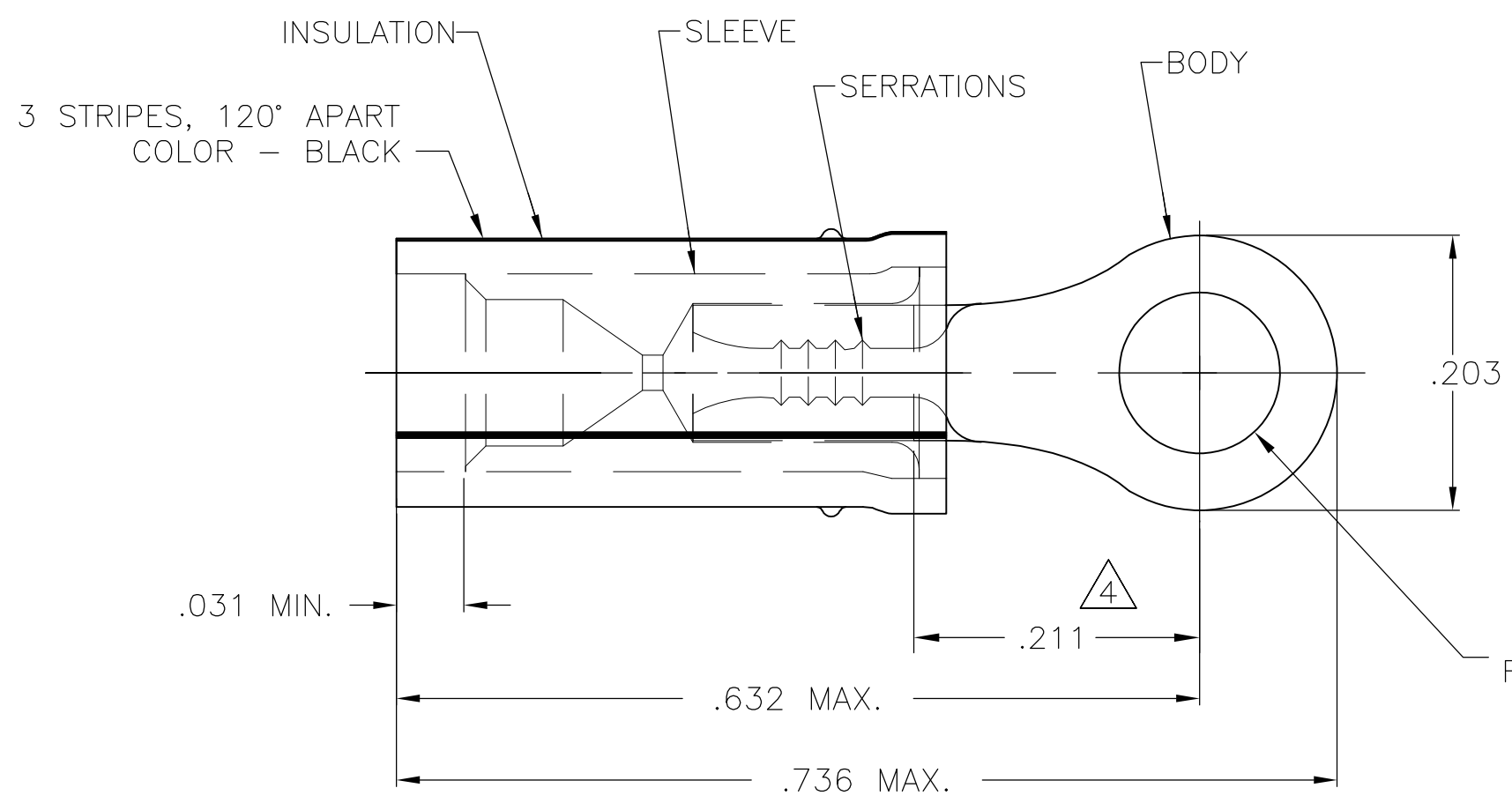

- 1 TONGUE MATERIAL THK: .027±.001.
- 2 FOR .026 TO .055 WIRE INS. OD.
- 3 MUST BE CRIMPED WITH 22-18 OR 22-16 PIDG (RED) TOOL.
- △4 APPLIED FROM EDGE OF METAL WIRE BARREL TO CENTER OF STUD HOLE.
- △5 BODY & SLEEVE: CU PER ASTM B152 INSULATION: NYLON, COLOR - YELLOW.
- △6 BODY: TIN PLATE PER ASTM B545 SLEEVE: NI PLATE PER QQ-N-290.

|                        |     |               |         |
|------------------------|-----|---------------|---------|
| M7928/1-2 CLASS 1 & 2  | 1   | WIRE TERMINAL | 53049   |
| MILITARY P/N AND CLASS | QTY | PACKAGE TYPE  | PART NO |

|  |  |   |  |  |                                    |                            |       |           |            |                         |
|--|--|---|--|--|------------------------------------|----------------------------|-------|-----------|------------|-------------------------|
| <b>AMP INCORPORATED<br/>CUSTOMER SERVICE SYSTEMS</b>                             |  | MAX RECOMMENDED OPERATING TEMPERATURE:<br>105°C [221°F]   | THIS DRAWING IS A CONTROLLED DOCUMENT. |  | DWN<br>JR RUTH<br>28OCT08          | <b>STE</b> TE Connectivity |       |           |            |                         |
| FOR ADDITIONAL PRODUCT INFORMATION OR COPIES OF DRAWINGS AND TECHNICAL DOCUMENTS | PRODUCT INFORMATION CENTER<br>1-800-522-6752 | VOLTAGE RATING:<br>300V MAX   | DIMENSIONS:<br>INCHES                  | TOLERANCES UNLESS OTHERWISE SPECIFIED:   | CHK<br>TOM MICHIELUTTI<br>28OCT08  |                            |       |           |            | NAME<br>TOM MICHIELUTTI |
| FOR APPLICATION TOOLING INFORMATION  | TOOLING ASSISTANCE CENTER<br>1-800-722-1111  | CIRCULAR MIL AREA:<br>0.12-0.15mm² [238-304] STRANDED   |  | 0 PLC ± -<br>1 PLC ± -<br>2 PLC ± .008<br>3 PLC ± -<br>4 PLC ± -<br>ANGLES ± - | APVD<br>TOM MICHIELUTTI<br>28OCT08 | PRODUCT SPEC               |       |           |            |                         |
| FOR ORDER ENTRY  | 1-800-526-5142                               | THIS DRAWING IS A CONTROLLED DOCUMENT FOR AMP INCORPORATED. IT IS SUBJECT TO CHANGE AND THE CONTROLLING ENGINEERING ORGANIZATION SHOULD BE CONTACTED FOR THE LATEST REVISION. | MATERIAL                               | FINISH   | PRODUCT SPEC                       | APPLICATION SPEC           | SIZE  | CAGE CODE | DRAWING NO | RESTRICTED TO           |
|  |  |   | △5                                     | △6   | —                                  | —                          | A3    | 00779     | C-53049    | —                       |
|  |  |   |  |  | CUSTOMER DRAWING                   |                            | SCALE | SHEET     | REV        |                         |
|  |  |   |  |  |                                    |                            | 8:1   | 1 OF 1    | F          |                         |