

THIS DRAWING IS UNPUBLISHED. RELEASED FOR PUBLICATION
 © COPYRIGHT 19 BY AMP INCORPORATED. ALL RIGHTS RESERVED.

LOC		DIST		REVISIONS			
P	LTR	DESCRIPTION		DATE	DWN	APVD	
	A	REV & REDRAW ON CAD PER EC 0320-70-97		11 MAR 97	-	-	
	B	REV PER EC 061C-95-98		14 JUL 98	CO	MC	

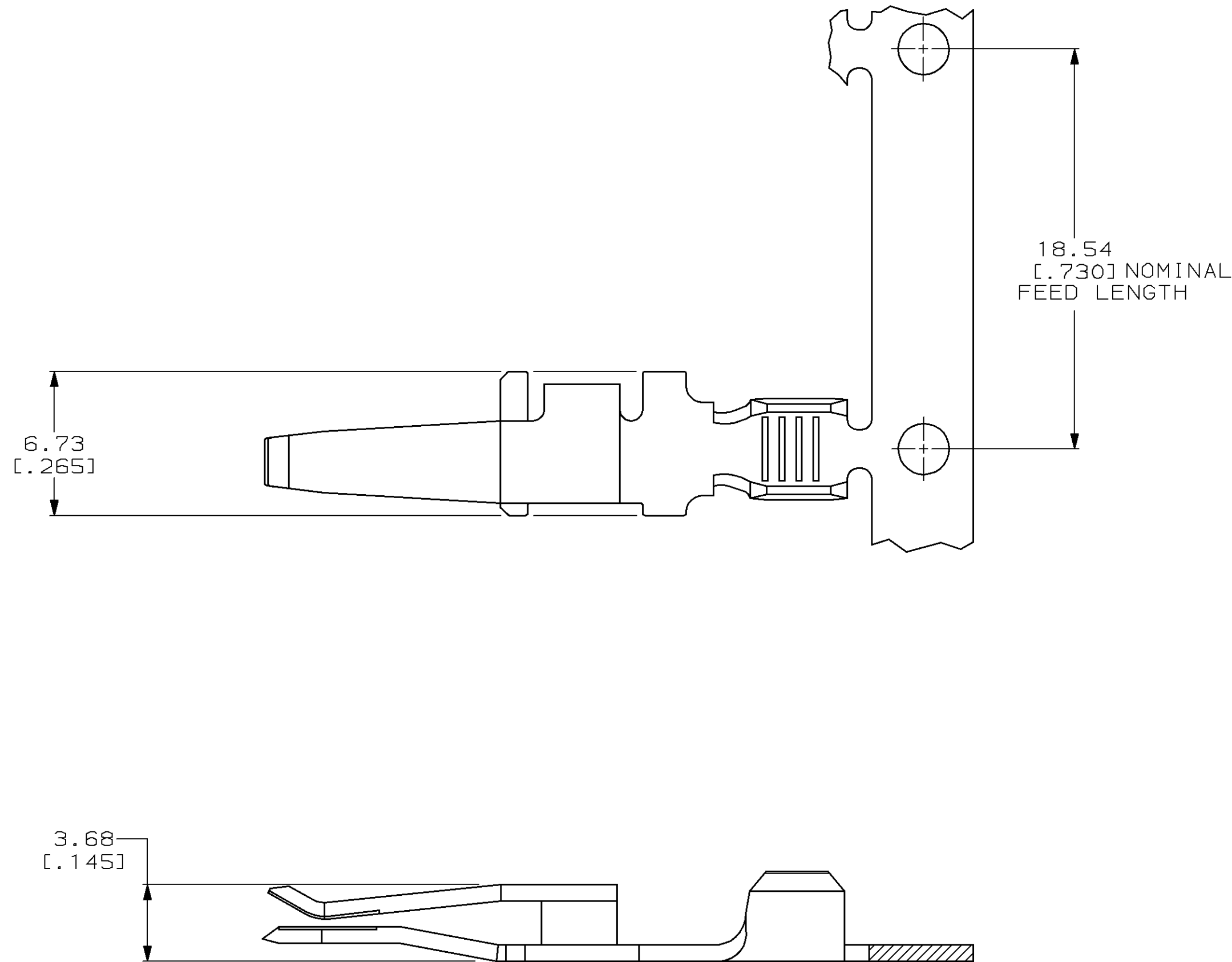

- ① ALL DIMENSIONS ARE MAXIMUM UNLESS OTHERWISE SPECIFIED.
- ② COPPER ALLOY.
- ③ 2.54µm [.000100] MIN TIN.
- 4. WIRE BARREL WILL ACCEPT ONE 18, 16 OR 14 AWG CU WIRE OR COMBINATIONS OF 18 AND 16 AWG CU WIRE.
- 5. THIS TERMINAL IS USED WITH HOUSING 556137 AND MOUNTING ADAPTER 557313-1.
- 6. APPLICATOR REEL: 567403-1 FOR "T" TERMINATOR, 567403-2 FOR AMP-O-ELECTRIC™ MODEL "K" MACHINE 565435-5.
- 7. HAND TOOL-LOOSE PIECE.

LOOSE PIECE	556135-2
ON STRIP	556135-1
DESCRIPTION	PART NUMBER

THIS DRAWING IS A CONTROLLED DOCUMENT.		DWN	M. BINNER	11 MAR 97
DIMENSIONS:		CHK	R. STONE	14 MAR 97
mm [INCHES]	TOLERANCES UNLESS OTHERWISE SPECIFIED:	APVD	M. McALONIS	17 MAR 97
0 PLC ±-	①	NAME	M. McALONIS	
1 PLC ±-	②	PRODUCT SPEC	108-1373	
2 PLC ±-	③	APPLICATION SPEC	114-6051	
3 PLC ±-	④	WEIGHT	-	
4 PLC ±-	⑤	CUSTOMER DRAWING	A2	
MATERIAL ②	FINISH ③	SIZE	CAGE CODE	DRAWING NO
		A2	00779	④-556135
		SCALE	SHEET	REV
		5:1	1 OF 1	B

AMP AMP Incorporated
Harrisburg, PA 17105-3608

TERMINAL, 18-16-14 AWG, FOLDED CRIMP, WTW, AMPINERGY™

556135

00

A