



Signal Double Lock (2.5 SDL) Connector System

1. SCOPE

1.1. Content

This specification defines performance, tests, and quality requirements for the Signal Double Lock (2.5 SDL) connector system.

1.2. Qualification

When tests are performed on the subject product line, procedures specified in Figure 1 shall be used. All inspections shall be performed using the applicable inspection plan and product drawing.

2. APPLICABLE DOCUMENTS

The following documents form a part of this specification to the extent specified herein. Unless otherwise specified, the latest edition of the document applies. In the event of conflict between the requirements of this specification and the product drawing, the product drawing shall take precedence. In the event of conflict between the requirements of this specification and the referenced documents, this specification shall take precedence.

2.1. TE Connectivity (TE) Documents

108-5459-8	Restricted Product Specification – Signal Double Lock (2.5 SDL) Connector System
108-5459-10	Restricted Product Specification – Signal Double Lock (2.5 SDL) Connector System
108-5459-11	Restricted Product Specification – Signal Double Lock (2.5 SDL) Connector System
114-5203	Application Specification – Signal Double Lock (2.5 SDL) Connector System
501-5223	Qualification Test Report – Signal Double Lock (2.5 SDL) Connector Hi-Pro Header
501-5224	Qualification Test Report – Signal Double Lock (2.5 SDL) Connector Standard Header
501-5230	Qualification Test Report – Signal Double Lock (2.5 SDL) Connector Wire to Wire Application
502-106179	Engineering Report – Signal Double Lock (2.5 SDL) Connector Withstanding Voltage Test

2.2. Industry Documents

EIA-364	Electrical Connector Test Procedures Including Environmental Classifications
IEC 60068	International Standard – Environmental Testing Procedures
IEC 60335	International Standard – Safety of Household and Similar Appliance
IEC 60512	International Standard – Connectors for Electronic Equipment – Tests and Measurements
IEC 61984	International Standard – Safety Requirements and Tests

2.3. Reference Documents

- 109-1 General Requirements for Testing
- 109-35 Contact Engaging and Separating Force Test Procedure
- TEC-109-11 Solderability Dip Test Procedure

3. REQUIREMENTS

3.1. Design and Construction

Product shall be of the design, construction, and physical dimensions specified on the applicable product drawing.

3.2. Materials

Materials used in the construction of this product shall be as specified on the applicable product drawing.

- A. Receptacle Contact and Tab Contact (Crimp): Pre-Tin Phosphor Bronze (Tin plating thickness: 0.8 μ m minimum)
- B. Plug and Cap Housing:
 - 1. 6/6 Nylon (UL 94V-0). Tracking Index: 600 V (minimum)
 - 2. 6/6 Nylon (Glass Filled 20%, UL 94V-0). Tracking Index: 250 – 399 V
- C. Double Lock Plate: 6/6 Nylon (Glass Filled 20%, UL 94V-0). Tracking Index: 250 – 399 V
- D. Header Assembly, Header Housing: 6/6 Nylon (Glass Filled 20%, UL 94V-0). Tracking Index: 250 – 399 V
- E. Header Assembly, Post Contact: Tin Plated Brass (Tin plating thickness: 0.8 μ m minimum)

3.3. Ratings

- A. Voltage: 250 VAC
- B. Current: 3 A (refer to Figure 1 for maximum allowable current to be applied)

Wire Size [AWG]	Maximum Current [A]	
	2.5 mm Pitch	5.0 mm Pitch
20	3	5
22	2.5	2.5
24	2.2	2.2
26	2	2

Figure 1

- C. Temperature: -30°C to 105°C (include temperature rise due to energized current)
- D. Minimum Rating: 1mV, 1 μ A (minimum)
- E. PCB Requirements
 - 1. Thickness: 1.6 mm
 - 2. Diameter of Thru Hole, for Tine: 0.9 \pm 0.05 mm (punched hole), 1.1 \pm 0.05 mm (drilled hole)
 - 3. Diameter of Thru Hole, for Boss: 1.7 \pm 0.05 mm (punched & drilled hole)

3.4. Performance and Test Description

Product is designed to meet the electrical, mechanical, and environmental performance requirements specified in Figure 2Figure 1. Unless otherwise specified, all tests shall be performed at ambient environmental conditions.

3.5. Test Requirements and Procedures Summary

Test Description	Requirement	Procedure		
Examination of Product	Meets requirements of product drawing and TE Specification 114-5203.	EIA-364-18 Visual inspection. No physical damage.		
Electrical				
Low Level Contact Resistance	Initial: 10 mΩ (maximum) Final: 20 mΩ (maximum)	EIA-364-23 Measure between contact and at wire 75 mm from end of contact. Protect wire from corrosion during testing. Test on mated connectors. Subtract bulk wire resistance from measurement. See Figure 3 and Figure 4. Test Current: 10 mA (maximum) Voltage: 20 mV (maximum)		
Dielectric Withstanding Voltage	No creeping discharge or flashover shall occur. Leakage Current: 5 mA (maximum)	EIA-364-20, Method B Apply 1100 VAC (for 2.5 mm pitch) or 1500 VAC (for 5 mm pitch) to adjacent circuits and hold at specified voltage for 1 minute. Test on mated connector.		
Insulation Resistance	Initial: 500 MΩ (minimum) Final: 500 MΩ (minimum)	EIA-364-21 Apply 500 VDC between adjacent contacts. Test on mated connector.		
Temperature Rise vs. Current	30°C maximum temperature rise	EIA-364-70, Method 2 Measure temperature rise caused by energized current. See Figure 3 and Figure 4.		
Mechanical				
Crimp Tensile Strength	Wire Size		EIA-364-8 Operation Speed: 100 mm/min Apply an axial pull-off load to a wire crimped onto contact secured in the testing machine.	
	mm²	AWG		Crimp Tensile (minimum) [N (kgf)]
	0.14	26		19.6 (2.0)
	0.22	24		29.4 (3.0)
	0.31	22		49.0 (5.0)
	0.51	20	58.8 (6.0)	
Post Retention Force	Mating Side: 14.7 N [1.5 kgf] (minimum) Tine Side: 9.8 N [1.0 kgf] (minimum)	EIA-364-29 Operation Speed: 100 mm/min Measure post retention force.		

Figure 2 (continued)

Contact Retention Force in Plastic Housing	6/6 Nylon (UL 94V-0) Housing Material: 14.7 N [1.5 kgf] (minimum) 6/6 Nylon (Glass Filled 20%, UL 94V-0) Housing Material: 19.6 N [2.0 kgf] (minimum)		EIA-364-05 Operation Speed: 100 mm /min Apply an axial pull-off load to crimped wire.																																										
Contact Insertion Force into Plastic Housing	6/6 Nylon (UL 94V-0) Housing Material: 5.88 N [0.6 kgf] (minimum) 6/6 Nylon (Glass Filled 20%, UL 94V-0) Housing Material: 7.84 N [0.8 kgf] (minimum)		EIA-364-05 Measure the force required to insert contact into the housing.																																										
Connector Mating Force	Initial and final limits are the same.		EIA-364-13 Operation Speed: 100 mm/min Measure the force required to mate connectors initially and after 30 cycles.																																										
	<table border="1"> <thead> <tr> <th>Position</th> <th>Force [N (kgf)] (maximum)</th> </tr> </thead> <tbody> <tr><td>2P</td><td>11.76 [1.2]</td></tr> <tr><td>3P</td><td>17.64 [1.8]</td></tr> <tr><td>4P</td><td>23.52 [2.4]</td></tr> <tr><td>5P</td><td>29.40 [3.0]</td></tr> <tr><td>6P</td><td>35.28 [3.6]</td></tr> <tr><td>7P</td><td>41.16 [4.2]</td></tr> <tr><td>8P</td><td>47.04 N [4.8]</td></tr> <tr><td>9P</td><td>52.92 [5.4]</td></tr> <tr><td>10P</td><td>58.80 [6.0]</td></tr> <tr><td>11P</td><td>64.68 N [6.6]</td></tr> <tr><td>12P</td><td>70.56 [7.2]</td></tr> <tr><td>13P</td><td>76.44 N [7.8]</td></tr> <tr><td>15P</td><td>88.20 [9.0]</td></tr> </tbody> </table>	Position		Force [N (kgf)] (maximum)	2P	11.76 [1.2]	3P	17.64 [1.8]	4P	23.52 [2.4]	5P	29.40 [3.0]	6P	35.28 [3.6]	7P	41.16 [4.2]	8P	47.04 N [4.8]	9P	52.92 [5.4]	10P	58.80 [6.0]	11P	64.68 N [6.6]	12P	70.56 [7.2]	13P	76.44 N [7.8]	15P	88.20 [9.0]															
	Position	Force [N (kgf)] (maximum)																																											
	2P	11.76 [1.2]																																											
	3P	17.64 [1.8]																																											
	4P	23.52 [2.4]																																											
	5P	29.40 [3.0]																																											
	6P	35.28 [3.6]																																											
	7P	41.16 [4.2]																																											
	8P	47.04 N [4.8]																																											
	9P	52.92 [5.4]																																											
	10P	58.80 [6.0]																																											
	11P	64.68 N [6.6]																																											
12P	70.56 [7.2]																																												
13P	76.44 N [7.8]																																												
15P	88.20 [9.0]																																												
2P	11.76 [1.2]																																												
3P	17.64 [1.8]																																												
4P	23.52 [2.4]																																												
5P	29.40 [3.0]																																												
6P	35.28 [3.6]																																												
7P	41.16 [4.2]																																												
8P	47.04 N [4.8]																																												
9P	52.92 [5.4]																																												
10P	58.80 [6.0]																																												
11P	64.68 N [6.6]																																												
12P	70.56 [7.2]																																												
13P	76.44 N [7.8]																																												
15P	88.20 [9.0]																																												
Connector Unmating Force	<table border="1"> <thead> <tr> <th>Position</th> <th>Initial: Force [N (kgf)] (maximum)</th> <th>Final: Force [N (kgf)] (maximum)</th> </tr> </thead> <tbody> <tr><td>2P</td><td>1.18 [0.12]</td><td>0.58 [0.06]</td></tr> <tr><td>3P</td><td>1.77 [0.18]</td><td>0.87 [0.09]</td></tr> <tr><td>4P</td><td>2.36 [0.24]</td><td>1.16 [0.12]</td></tr> <tr><td>5P</td><td>2.95 [0.30]</td><td>1.45 [0.15]</td></tr> <tr><td>6P</td><td>3.54 [0.36]</td><td>1.74 [0.18]</td></tr> <tr><td>7P</td><td>4.13 [0.42]</td><td>2.03 [0.21]</td></tr> <tr><td>8P</td><td>4.72 [0.48]</td><td>2.32 [0.24]</td></tr> <tr><td>9P</td><td>5.31 [0.54]</td><td>2.61 [0.27]</td></tr> <tr><td>10P</td><td>5.90 [0.60]</td><td>2.94 [0.30]</td></tr> <tr><td>11P</td><td>6.49 [0.66]</td><td>3.19 [0.33]</td></tr> <tr><td>12P</td><td>7.08 [0.72]</td><td>3.48 [0.36]</td></tr> <tr><td>13P</td><td>7.67 [0.78]</td><td>3.77 [0.39]</td></tr> <tr><td>15P</td><td>8.82 [0.90]</td><td>4.41 [0.45]</td></tr> </tbody> </table>	Position	Initial: Force [N (kgf)] (maximum)	Final: Force [N (kgf)] (maximum)	2P	1.18 [0.12]	0.58 [0.06]	3P	1.77 [0.18]	0.87 [0.09]	4P	2.36 [0.24]	1.16 [0.12]	5P	2.95 [0.30]	1.45 [0.15]	6P	3.54 [0.36]	1.74 [0.18]	7P	4.13 [0.42]	2.03 [0.21]	8P	4.72 [0.48]	2.32 [0.24]	9P	5.31 [0.54]	2.61 [0.27]	10P	5.90 [0.60]	2.94 [0.30]	11P	6.49 [0.66]	3.19 [0.33]	12P	7.08 [0.72]	3.48 [0.36]	13P	7.67 [0.78]	3.77 [0.39]	15P	8.82 [0.90]	4.41 [0.45]		EIA-364-13 Operation Speed: 100 mm/min Measure the force required to unmate connectors initially and after 30 cycles.
	Position	Initial: Force [N (kgf)] (maximum)	Final: Force [N (kgf)] (maximum)																																										
	2P	1.18 [0.12]	0.58 [0.06]																																										
	3P	1.77 [0.18]	0.87 [0.09]																																										
	4P	2.36 [0.24]	1.16 [0.12]																																										
	5P	2.95 [0.30]	1.45 [0.15]																																										
	6P	3.54 [0.36]	1.74 [0.18]																																										
	7P	4.13 [0.42]	2.03 [0.21]																																										
	8P	4.72 [0.48]	2.32 [0.24]																																										
	9P	5.31 [0.54]	2.61 [0.27]																																										
	10P	5.90 [0.60]	2.94 [0.30]																																										
	11P	6.49 [0.66]	3.19 [0.33]																																										
	12P	7.08 [0.72]	3.48 [0.36]																																										
13P	7.67 [0.78]	3.77 [0.39]																																											
15P	8.82 [0.90]	4.41 [0.45]																																											
2P	1.18 [0.12]	0.58 [0.06]																																											
3P	1.77 [0.18]	0.87 [0.09]																																											
4P	2.36 [0.24]	1.16 [0.12]																																											
5P	2.95 [0.30]	1.45 [0.15]																																											
6P	3.54 [0.36]	1.74 [0.18]																																											
7P	4.13 [0.42]	2.03 [0.21]																																											
8P	4.72 [0.48]	2.32 [0.24]																																											
9P	5.31 [0.54]	2.61 [0.27]																																											
10P	5.90 [0.60]	2.94 [0.30]																																											
11P	6.49 [0.66]	3.19 [0.33]																																											
12P	7.08 [0.72]	3.48 [0.36]																																											
13P	7.67 [0.78]	3.77 [0.39]																																											
15P	8.82 [0.90]	4.41 [0.45]																																											

Figure 2 (continued)

Durability (Repeated Mating/Unmating)	No evidence of physical damage or abnormalities.	EIA-364-9 Number of cycles: 30
Sinusoidal Vibration	No electrical discontinuity greater than 1 μ s shall occur.	EIA-364-28, Test Condition I Subject mated connectors to 10-55-10 Hz traversed in 1 minute at 1.52 mm amplitude for 2 hours each in 3 mutually perpendicular planes. Apply 100 mA. See Figure 5.
Physical Shock	No electrical discontinuity greater than 1 μ s shall occur. No evidence of physical damage or abnormalities.	EIA-364-27, Test Condition A Acceleration: 490 m/s ² (50 G) Waveform: Half sine curve Velocity Change: 3.4 m/s Number of Drops: 3 drops each in normal and reserved directions for X, Y, and Z axes for a total of 18 drops Mounting: See Figure 5.
Connector Locking Strength	24.5 N [2.5 kgf] (minimum)	EIA-364-98 Operation Speed: 100 mm/min Measure connector locking strength.
Double Lock Plate Locking Force (Secondary Lock)	14.7 N [1.5 kgf] (minimum)	Operation Speed: 100 mm/min Measure double lock plate locking force.
Contact Mating Force	5.88 N [0.6 kgf] (maximum)	109-35 Operation Speed: 100 mm/min Measure by gauge tab. See Figure 7. Take initial measurement only.
Contact Unmating Force	Initial: 0.2 N [20 gf] (minimum) Final (after 30 cycles): 0.1 N [10 gf] (minimum)	109-35 109-5206 (Based on JIS C 540206.4) Operation Speed: 100 mm/min Measure by gauge tab. See Figure 7. Take initial measurement and measurement after 30 cycles.
Hammering Shocks	No evidence of physical damage or abnormalities.	Subject mated connectors to less than 10,000 cycles of repeated hammering shocks. See Figure 6. Hammering Height: 80 mm Hammering Weight: 50 g Hammering Speed: 1 cycle/second Apply 10 VDC and 1 mA.
Environmental		
Solderability	Wet Solder Coverage: 95% (minimum)	TEC-109-11 Solder Temperature: 230 \pm 5°C Flux: Alpha 100 Immersion Duration: 3 \pm 0.5 seconds

Figure 2 (continued)

Cold	No evidence of physical damage or abnormalities.	IEC 60068-2-1 Subject mated connected to $-30 \pm 3^{\circ}\text{C}$ for 96 hours.
Thermal Shock	No evidence of physical damage or abnormalities.	EIA-364-32 Subject mated connector to 25 cycles of thermal shock. Each cycle is 1 hour with 30 minutes held at -55°C and 30 minutes held at 85°C .
Humidity-Temperature Cycling	No evidence of physical damage or abnormalities.	EIA-364-31 Subject mated connector to 10 cycles between a temperature of 25°C and 65°C and 90-95% RH. Perform cold shock at -10°C .
Salt Spray	No evidence of physical damage or abnormalities.	EIA-364-26 Subject mated connectors to 5% salt spray concentration for 48 hours.
Resistance to Soldering Heat	No evidence of physical damage or abnormalities.	EIA-364-56 Test connector on PCB. Solder Temperature: $265 \pm 5^{\circ}\text{C}$ Immersion Duration: 5 ± 1 second In case of manual soldering iron, apply it as $360 \pm 10^{\circ}\text{C}$ for 3 ± 0.5 seconds without forcing pressure to affect the time of the contact.
Industrial Gas (SO ₂)	No evidence of physical damage or abnormalities.	Subject mated connectors to SO ₂ gas (3 ± 1 ppm, 95% RH) at $40 \pm 2^{\circ}\text{C}$ for 96 hours.
Temperature Life (Heat Age)	No evidence of physical damage or abnormalities.	EIA-364-17 Subject mated connector to 105°C for 4 days.
Resistance to Ammonia	No evidence of physical damage or abnormalities.	Subject mated connector to 3% ammonia solution (25 mL/L) in desiccator for 7 hours.

NOTE

Shall meet visual requirements, show no physical damage, and meet requirements of additional tests as specified in the product qualification and re-qualification test sequence given in Figure 8.

Figure 2 (end)

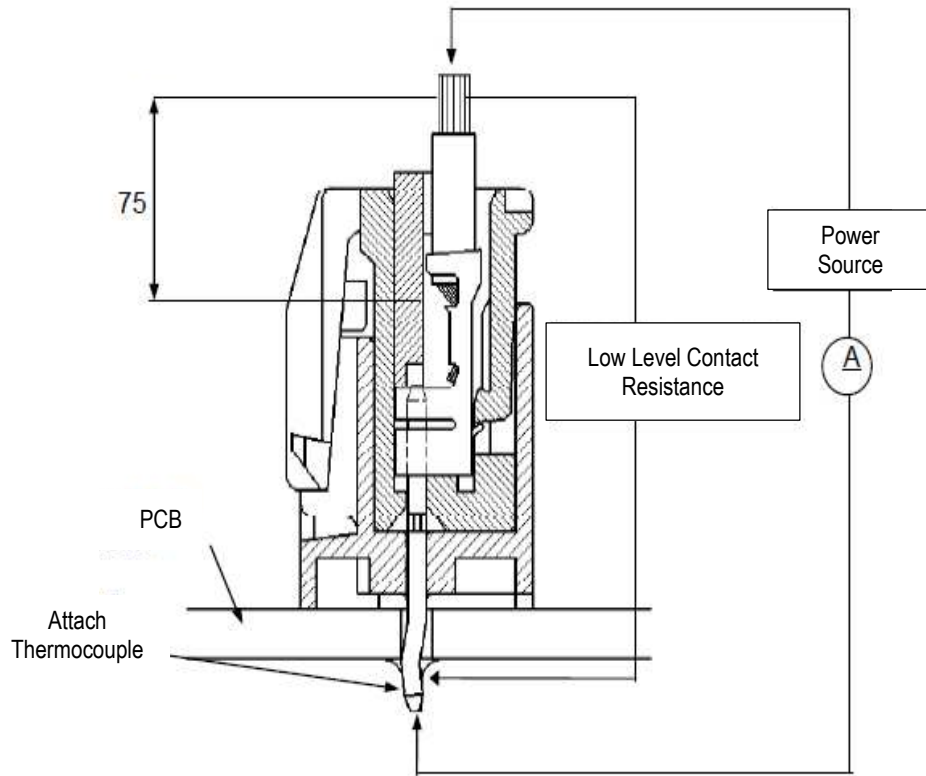

Figure 3: Wire to Board Connector Set-up for Low Level Contact Resistance and Temperature Rise vs. Current Testing

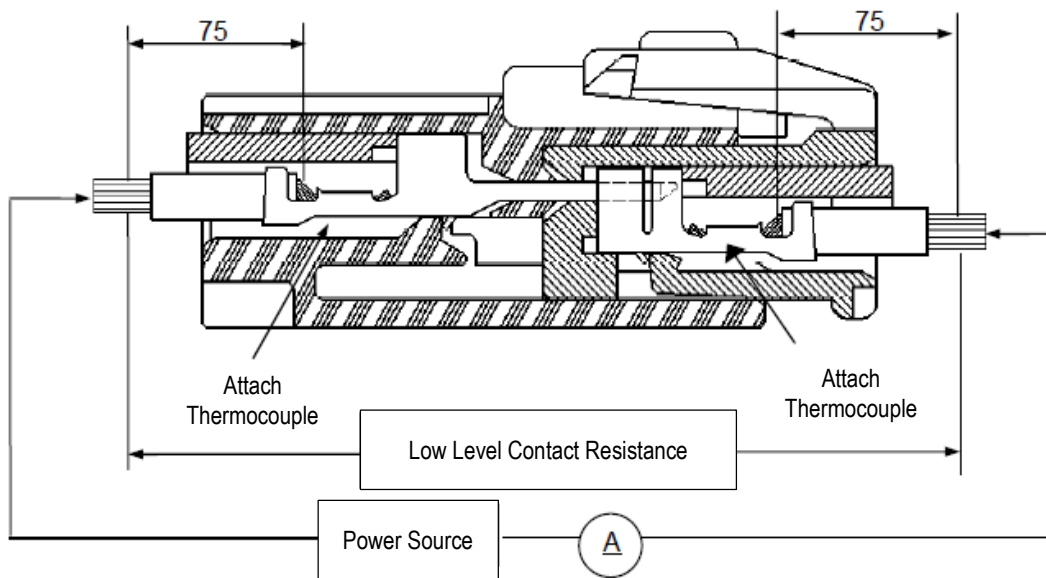

Figure 4: Wire to Wire Connector Set-up for Low Level Contact Resistance and Temperature Rise vs. Current Testing

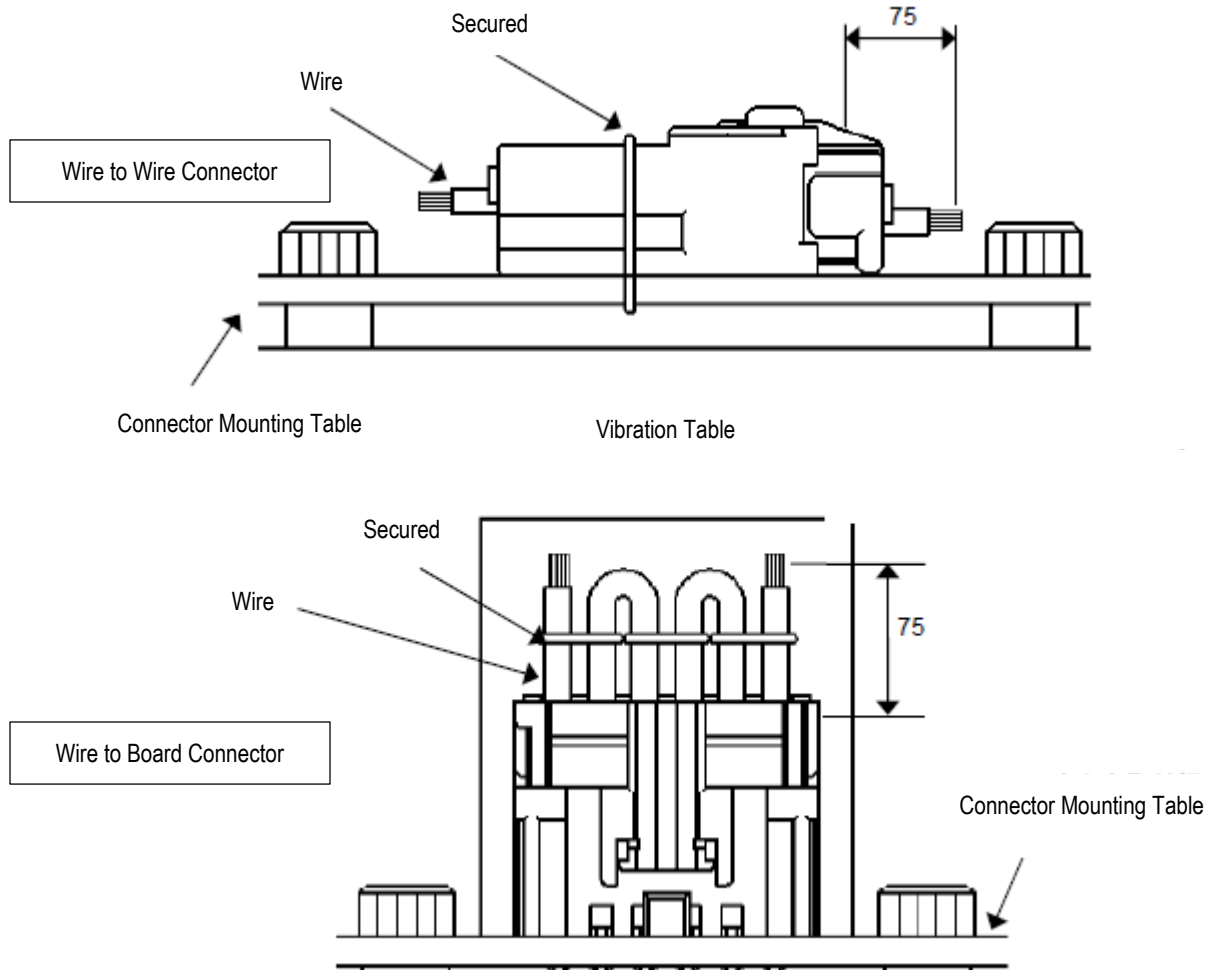

Figure 5: Connector Mounting Method for Sinusoidal Vibration and Physical Shock Tests

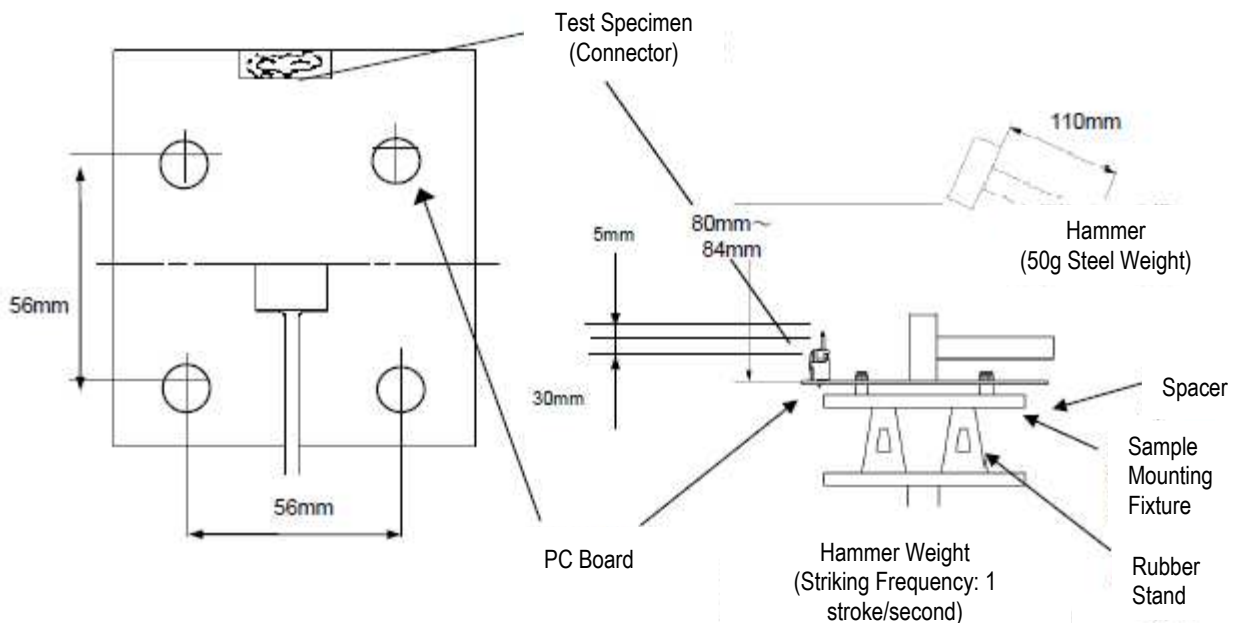

Figure 6

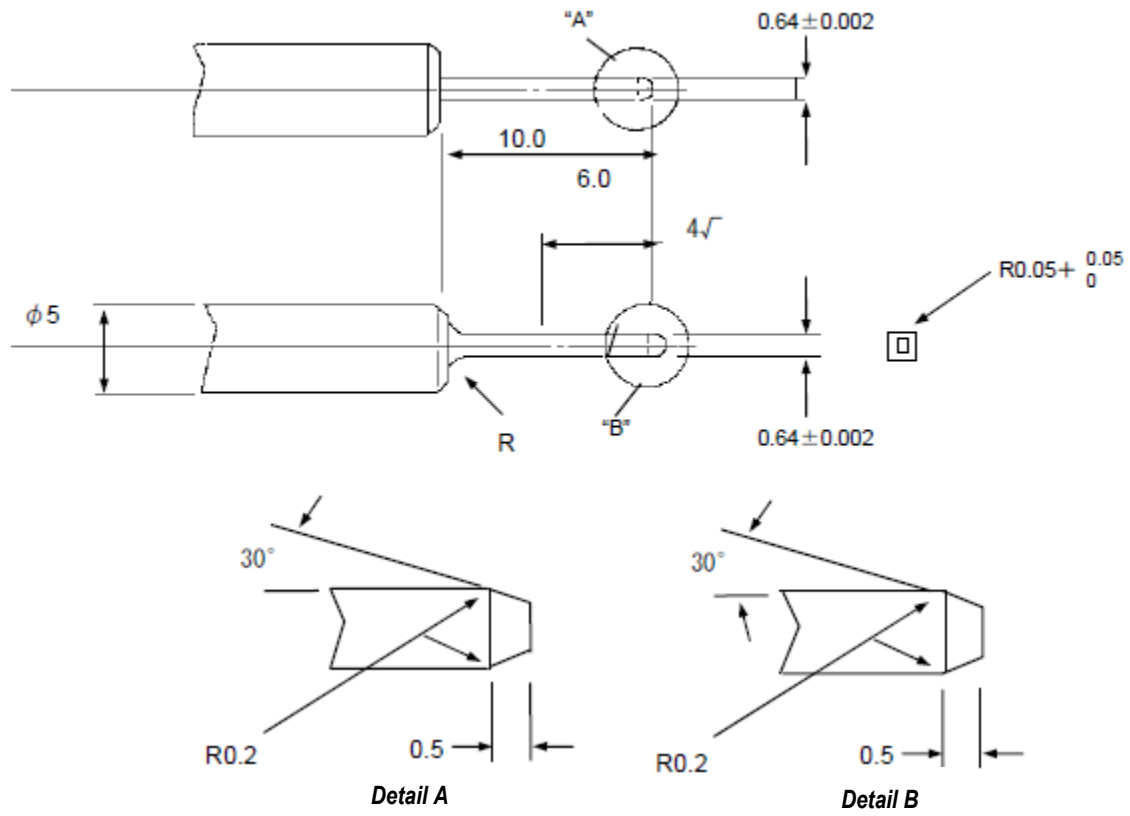

Figure 7: Gage Design for Contact Mating/Unmating Force Test

3.6. Product Qualification and Re-Qualification Test Sequence

TEST OR EXAMINATION	TEST GROUP (a)										
	1	2	3	4	5	6	7	8	9	10	11
	TEST SEQUENCE (b)										
Examination of Product	1, 3	1, 4	1, 3	1	1, 3	1, 4	1, 7	1, 7	1, 5	1, 4	1, 4
Low Level Contact Resistance							2, 4, 6	2, 6	2, 4	2, 5	2, 5
Dielectric Withstanding Voltage						3					
Insulation Resistance						2					
Temperature Rise vs. Current					2						
Crimp Tensile Strength	2										
Post Retention Force											
Contact Retention Force						5					
Contact Insertion Force				2							
Connector Mating Force								3			
Connector Unmating Force								4			
Durability (Repeated Mating/Unmating)								5			
Sinusoidal Vibration							5				
Physical Shock							3				
Connector Locking Strength			2								
Double Lock Plate Locking Force (Secondary Lock)											
Contact Mating Force		2									
Contact Unmating Force		3									
Hammering Shocks											
Solderability											
Cold											
Thermal Shock									3		
Humidity-Temperature Cycling											
Salt Spray										3	
Resistance to Soldering Heat											
Industrial Gas (SO ₂)											
Temperature Life (Heat Age)											3
Resistance to Ammonia											

Figure 8 (continued)

TEST OR EXAMINATION	TEST GROUP (a)									
	12	13	14	15	16	17	18	19	20	21
	TEST SEQUENCE (b)									
Examination of Product	1, 4	1, 4	1, 5	1, 3	1, 3	1, 3	1, 5	1, 4	1, 3	1, 4
Low Level Contact Resistance	2, 5	2, 5	2, 4				2, 4	2, 5		2, 5
Dielectric Withstanding Voltage								7		
Insulation Resistance								6		
Temperature Rise vs. Current										
Crimp Tensile Strength										
Post Retention Force					2					
Contact Retention Force										
Contact Insertion Force										
Connector Mating Force										
Connector Unmating Force										
Durability (Repeated Mating/Unmating)										
Sinusoidal Vibration										
Physical Shock										
Connector Locking Strength										
Double Lock Plate Locking Force (Secondary Lock)									2	
Contact Mating Force										
Contact Unmating Force										
Hammering Shocks							3			
Solderability				2						
Cold	3									
Thermal Shock										
Humidity-Temperature Cycling								3		
Salt Spray										
Resistance to Soldering Heat						2				
Industrial Gas (SO ₂)		3								
Temperature Life (Heat Age)										
Resistance to Ammonia			3							

NOTE

(a) See paragraph 4.1.A.

(b) Numbers indicate sequence in which tests are performed.

Figure 8 (end)

4. QUALITY ASSURANCE PROVISIONS

4.1. Qualification Testing

A. Specimen Selection

Specimens shall be prepared in accordance with applicable instruction sheets and shall be selected at random from current production. The wires crimped to the contacts must meet the requirements in Figure 9.

Cross Sectional Area [mm ²]	Wire Size [AWG]	Diameter of a Single Conductor [mm]	Number of Conductors	Insulation Outer Diameter [mm]
0.14	26	0.16	7	1.3
0.22	24	0.16	11	1.4
0.34	22	0.16	17	1.5
0.53	20	0.16	21	1.8

Figure 9

B. Test Sequence

Qualification inspection shall be verified by testing specimens as specified in Figure 8.

4.2. Re-Qualification Testing

If changes that significantly affecting form, fit, or function are made to the product or manufacturing process, product assurance shall coordinate re-qualification testing consisting of all or part of the original testing sequence as determined by development/product, quality, and reliability engineering.

4.3. Acceptance

Acceptance is based on verification that the product meets the requirements of Figure 2. Failures attributed to equipment, test setup, or operator deficiencies shall not disqualify the product. If product failure occurs, corrective action shall be taken and specimens re-submitted for qualification. Testing to confirm corrective action is required before re-submittal.

4.4. Quality Conformance Inspection

The applicable quality inspection plan shall specify the sampling acceptable quality level to be used. Dimensional and functional requirements shall be in accordance with the applicable product drawing and this specification.

APPENDIX

The applicable product descriptions and base numbers are shown in Figure 10.

917683	Receptacle Contact
917684	Receptacle Contact
917764	Tab Contact
917765	Tab Contact
917686	2P Plug Housing
917687	3P Plug Housing
917688	4P Plug Housing
917689	5P Plug Housing
917690	6P Plug Housing
917691	7P Plug Housing
917692	8P Plug Housing
917693	9P Plug Housing
917694	10P Plug Housing
917695	11P Plug Housing
917696	12P Plug Housing
917697	13P Plug Housing
353557	15P Plug Housing
1318989	2P Plug Housing (Glass Filled)
1318990	3P Plug Housing (Glass Filled)
1318991	4P Plug Housing (Glass Filled)
1318992	5P Plug Housing (Glass Filled)
1318993	6P Plug Housing (Glass Filled)
1318994	7P Plug Housing (Glass Filled)
1318995	8P Plug Housing (Glass Filled)
1318996	9P Plug Housing (Glass Filled)
1318997	10P Plug Housing (Glass Filled)
1318998	11P Plug Housing (Glass Filled)
1318999	12P Plug Housing (Glass Filled)
1376000	13P Plug Housing (Glass Filled)
1376001	15P Plug Housing (Glass Filled)
316086	2P Cap Housing
316087	3P Cap Housing
316088	4P Cap Housing
316089	5P Cap Housing
316090	6P Cap Housing
316091	7P Cap Housing

316092	8P Cap Housing
316094	10P Cap Housing
1565019	2P Cap Housing (Glass Filled)
1612304	3P Cap Housing (Glass Filled)
1612305	4P Cap Housing (Glass Filled)
1565020	5P Cap Housing (Glass Filled)
1376662	7P Cap Housing (Glass Filled)
1376663	8P Cap Housing (Glass Filled)
1376664	10P Cap Housing (Glass Filled)
917698	2P Double Lock Plate
917699	3P Double Lock Plate
917700	4P Double Lock Plate
917701	5P Double Lock Plate
917702	6P Double Lock Plate
917703	7P Double Lock Plate
917704	8P Double Lock Plate
917705	9P Double Lock Plate
917706	10P Double Lock Plate
917707	11P Double Lock Plate
917708	12P Double Lock Plate
917709	13P Double Lock Plate
353560	15P Double Lock Plate
917722	2P Hi-Pro Header Assembly
917723	3P Hi-Pro Header Assembly
917724	4P Hi-Pro Header Assembly
917725	5P Hi-Pro Header Assembly
917726	6P Hi-Pro Header Assembly
917727	7P Hi-Pro Header Assembly
917728	8P Hi-Pro Header Assembly
917729	9P Hi-Pro Header Assembly
917730	10P Hi-Pro Header Assembly
917731	11P Hi-Pro Header Assembly
917732	12P Hi-Pro Header Assembly
917733	13P Hi-Pro Header Assembly
917780	2P Standard Header Assembly
917781	3P Standard Header Assembly
917782	4P Standard Header Assembly
917783	5P Standard Header Assembly

917784	6P Standard Header Assembly
917785	7P Standard Header Assembly
917786	8P Standard Header Assembly
917787	9P Standard Header Assembly
917788	10P Standard Header Assembly
917789	11P Standard Header Assembly
917790	12P Standard Header Assembly
917791	13P Standard Header Assembly
353559	15P Standard Header Assembly
917894	2P Standard Radial Header Assembly
917895	3P Standard Radial Header Assembly
917896	4P Standard Radial Header Assembly
917897	5P Standard Radial Header Assembly
917898	6P Standard Radial Header Assembly
917899	7P Standard Radial Header Assembly
917900	8P Standard Radial Header Assembly
316531	2P Standard Tube Header Assembly
316532	3P Standard Tube Header Assembly
316533	4P Standard Tube Header Assembly
316534	5P Standard Tube Header Assembly
316535	6P Standard Tube Header Assembly
316536	7P Standard Tube Header Assembly
316732	2P 5mm Pitch STD Header Assembly
353350	3P 5mm Pitch STD Header Assembly
353351	4P 5mm Pitch STD Header Assembly
353352	5P 5mm Pitch STD Header Assembly
353353	6P 5mm Pitch STD Header Assembly
1565098	8P 5mm Pitch STD Header Assembly
353355	4P 7.5 Pitch STD Header Assembly
316879	2P 5mm Pitch Radial Header Assembly
316880	3P 5mm Pitch Radial Header Assembly
316881	4P 5mm Pitch Radial Header Assembly
1376274	2/4P Standard Option Header Assembly
353586	3/4P Standard Option Header Assembly
353230	4/5P Standard Option Header Assembly
1123551	4/6P Standard Option Header Assembly
1123276	4/8P Standard Option Header Assembly
353355	4/10P Standard Option Header Assembly

353556	5/8P Standard Option Header Assembly
1376272	6/9P Standard Option Header Assembly
353634	6/9P Standard Option Header Assembly
353635	6/10P Standard Option Header Assembly
1318364	6/10P Standard Option Header Assembly
353353	6/11P Standard Option Header Assembly
1318312	8/12P Standard Option Header Assembly
1123275	8/13P Standard Option Header Assembly
1123863	10/15P Standard Option Header Assembly
1123552	11/15P Standard Option Header Assembly
353562	3/4P Standard Radial Option Header Assembly
1123550	4/5P Standard Radial Option Header Assembly
353555	4/6P Standard Radial Option Header Assembly
1376273	2/4P Standard Tube Header Assembly
316221	2P Hi-Pro Radial Header Assembly
316222	3P Hi-Pro Radial Header Assembly
316223	4P Hi-Pro Radial Header Assembly
316224	5P Hi-Pro Radial Header Assembly
316225	6P Hi-Pro Radial Header Assembly
316226	7P Hi-Pro Radial Header Assembly
316227	8P Hi-Pro Radial Header Assembly
353205	2P 5mm Pitch Hi-Pro Header Assembly
353489	3P 5mm Pitch Hi-Pro Header Assembly
1318366	4P 5mm Pitch Hi-Pro Header Assembly
1318913	5P 5mm Pitch Hi-Pro Header Assembly
1123037	2P 5mm Pitch Hi-Pro Tube Header Assembly
1376672	5/8P Hi-Pro Option Header Assembly
316587	6/8P Hi-Pro Option Header Assembly

Figure 10