

THIS DRAWING IS UNPUBLISHED. RELEASED FOR PUBLICATION  
 © COPYRIGHT - By - ALL RIGHTS RESERVED.

LOC	DIST	REVISIONS					
AF	50	P	LTR	DESCRIPTION	DATE	DWN	APVD
			G	REVISED PER ECR-18-009392	01APR2019	BDA	SV

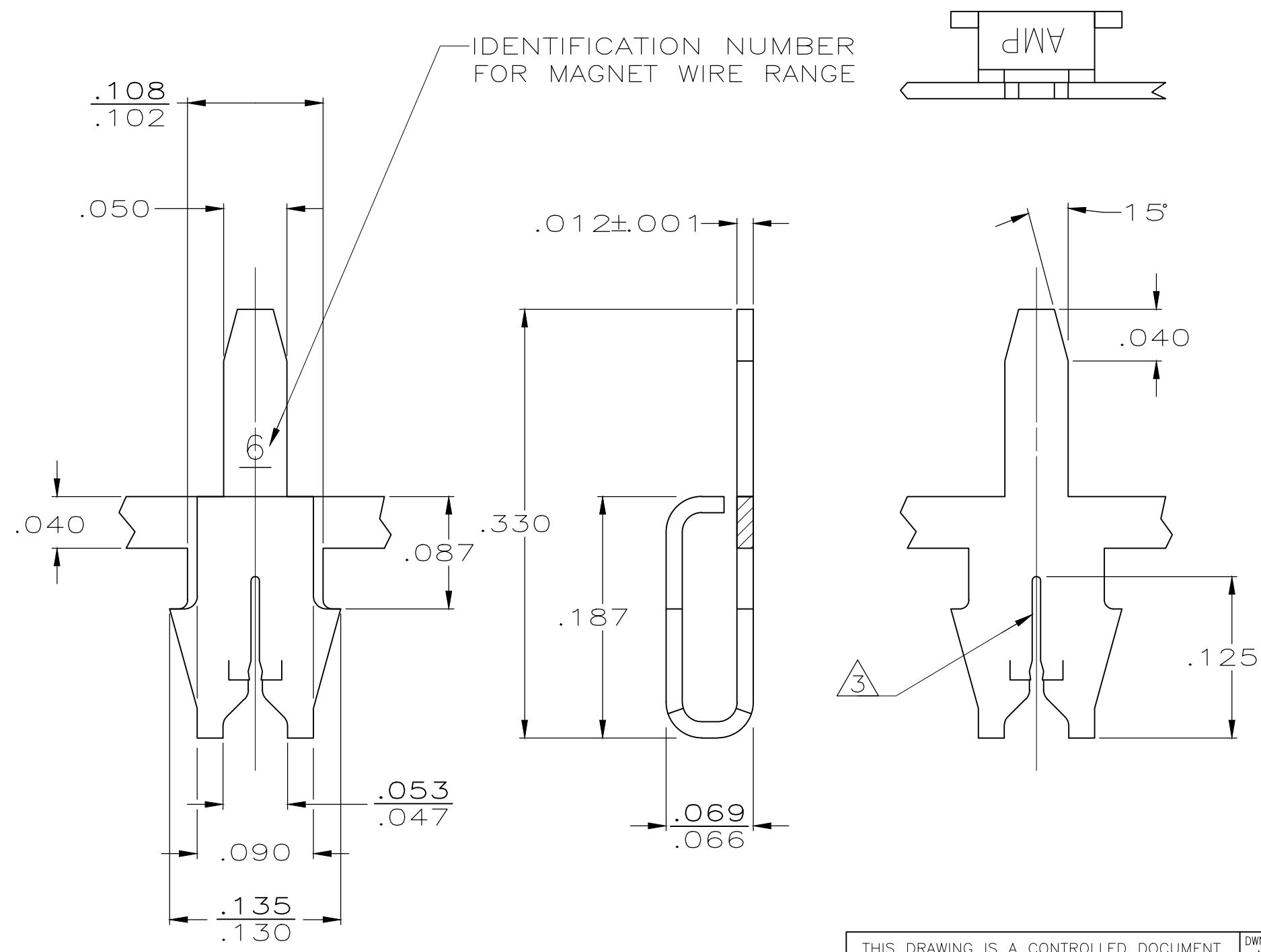

- ① MAG-MATE CAVITY SPECIFICATION.
- ② CONTINUOUS STRIP ON REELS WITH TERMINALS LOCATED ON .200 CENTERS.
- ③ SLOT ACCEPTS #30-#28 AWG COPPER MAGNET WIRE.
- ④ REELED FOR APPLICATION THROUGH MAG-MATE INSERTION MACHINE
- ⑤ REELED FOR INSERTION INTO PRINTED CIRCUIT BOARD
- ⑥ TIN PER MIL-T-10727

OBSOLETE	⑤	62430-2
	④	62430-1
	REELING	PART NO.

THIS DRAWING IS A CONTROLLED DOCUMENT.		DWN	M.S. FEHER	11/21/88	<b>STE</b> TE Connectivity		
DIMENSIONS: INCHES		CHK	JR RUTH	11/27/88			
TOLERANCES UNLESS OTHERWISE SPECIFIED:		APVD	-	11/28/88	NAME TERMINAL, POSTED, MAG-MATE™		
0 PLC ± -		PRODUCT SPEC	-	11/28/88			
1 PLC ± -		APPLICATION SPEC	-	11/28/88	SIZE A3		
2 PLC ± -		WEIGHT	-	C.G. ATHERTON			
3 PLC ± .010		114-2069 ①		RESTRICTED TO	CAGE CODE 00779		
4 PLC ± -		①		DRAWING NO G-62430			
ANGLES ± -		CUSTOMER DRAWING		SCALE	10:1		
FINISH ⑥		SCALE		SHEET 1 OF 1			
MATERIAL BRASS		SCALE					REV G
		SHEET		1 OF 1			