

DRAWING MADE IN THIRD ANGLE PROJECTION

THIS DRAWING IS UNPUBLISHED. RELEASED FOR PUBLICATION .19
 © COPYRIGHT 19 BY AMP INCORPORATED. ALL INTERNATIONAL RIGHTS RESERVED.

LOC	DIST	P	F	ZONE	LTR	DESCRIPTION	DATE	APPD
G	86				C	Add tin plating reference	12JUN2017	MV

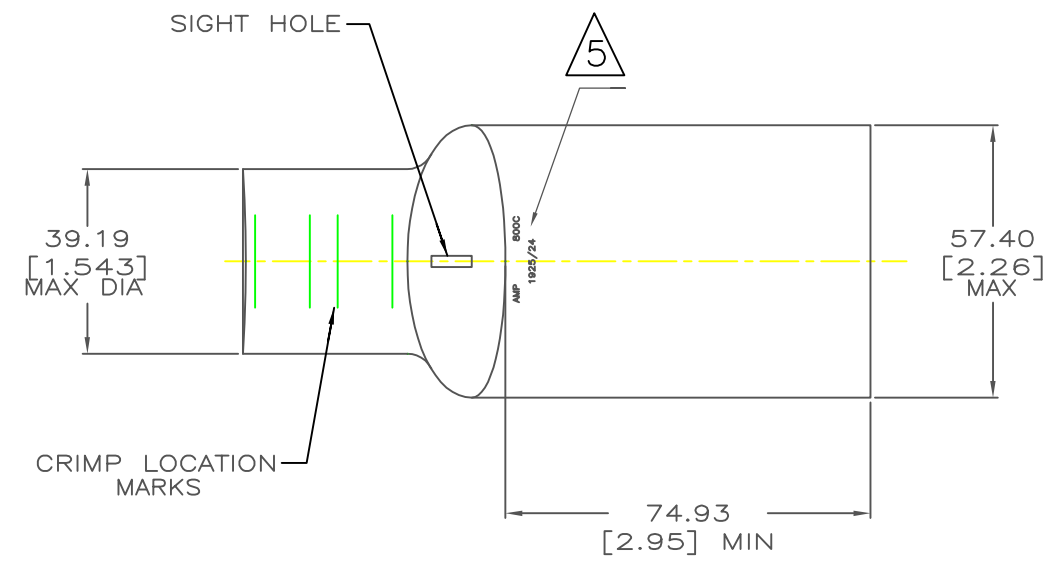

- 1 CIRCULAR MIL RANGE: 750-850 MCM
- 2 CLEANED, UNPLATED
- 4 TIN PL 0.00381[.000150]
MIN THK PER ASTM B 545
- 5 STAMPED AMP 800C 1925/24

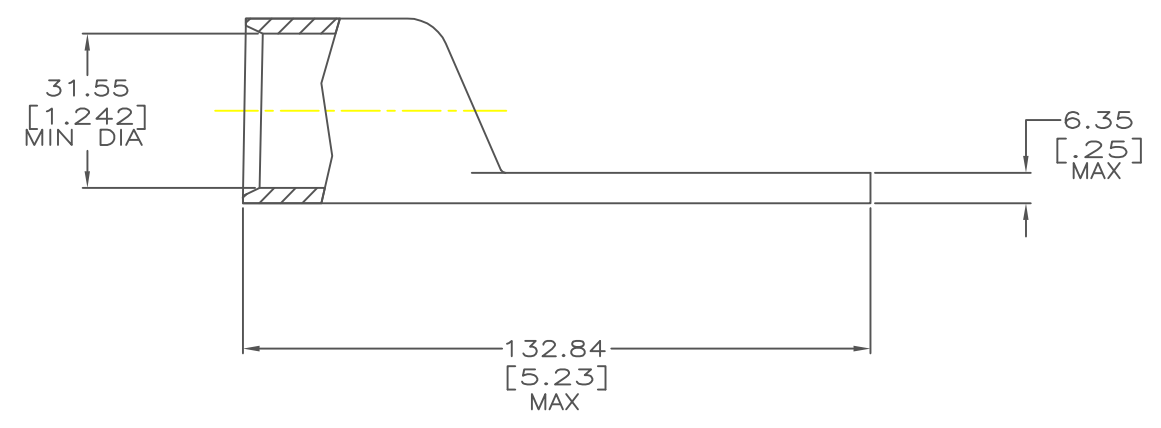

696279

DO NOT SCALE PRINT. UNLESS SPECIFIED		DR 24JAN01 JR RUTH		FINISH		696279-2	
DIMENSIONS IN mm [INCHES]		CHK 24JAN01 MS FEHER		AMP INCORPORATED		696279-1	
TOLERANCES ON :		APPD 24JAN01 M SPICER		Harrisburg, Pa. 17105		PART NO	
2 PLC DEC ± 0.51[.020]		APPD 24JAN01 M SPICER		NAME TERMINAL, AMPPOWER™ WIRE SIZE: 800 MCM			
3 PLC DEC ± -		APPD 24JAN01 M SPICER					
ANGLES ± -		PRODUCT SPEC		SIZE			
MATERIAL		108-30200		C		CAGE CODE	
ANNEALED COPPER		APPLICATION SPEC		00779		DRAWING NO	
ASTM B-75		-		1:1		696279	
FINISH		WEIGHT .821 LB		SCALE		SHEET	
SEE NOTES				1:1		10F 1	

