

THIS DRAWING IS UNPUBLISHED. RELEASED FOR PUBLICATION 20
 © COPYRIGHT 20 y ALL RIGHTS RESERVED.

LOC	DIST	REVISIONS					
IR	-	P	LTR	DESCRIPTION	DATE	DWN	APVD
		AV5		REVISED PER ECR-16-016851	28NOV2016	HG	TD
		AV6		REVISED PER ECR-19-012306	24MAR2020	SS	DL

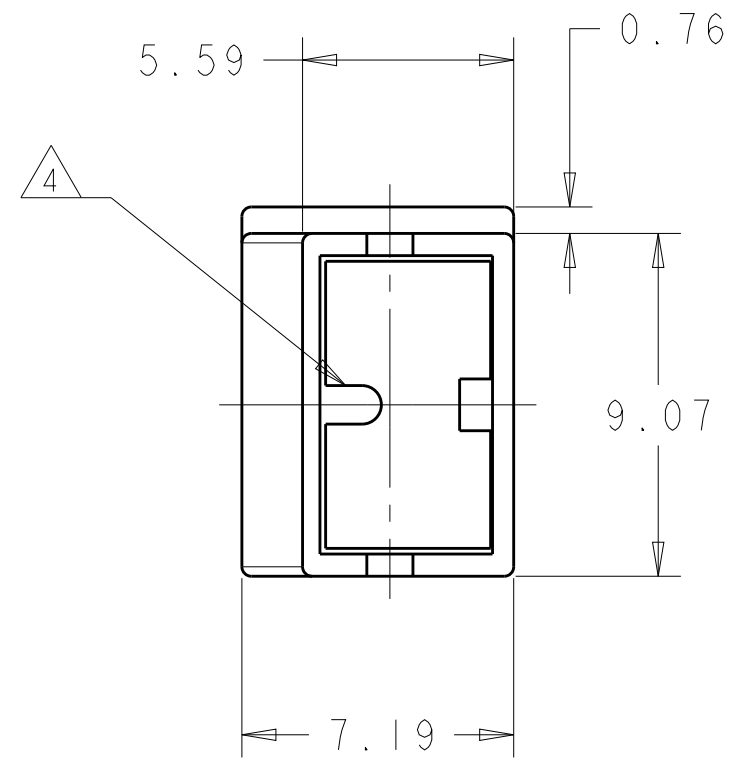
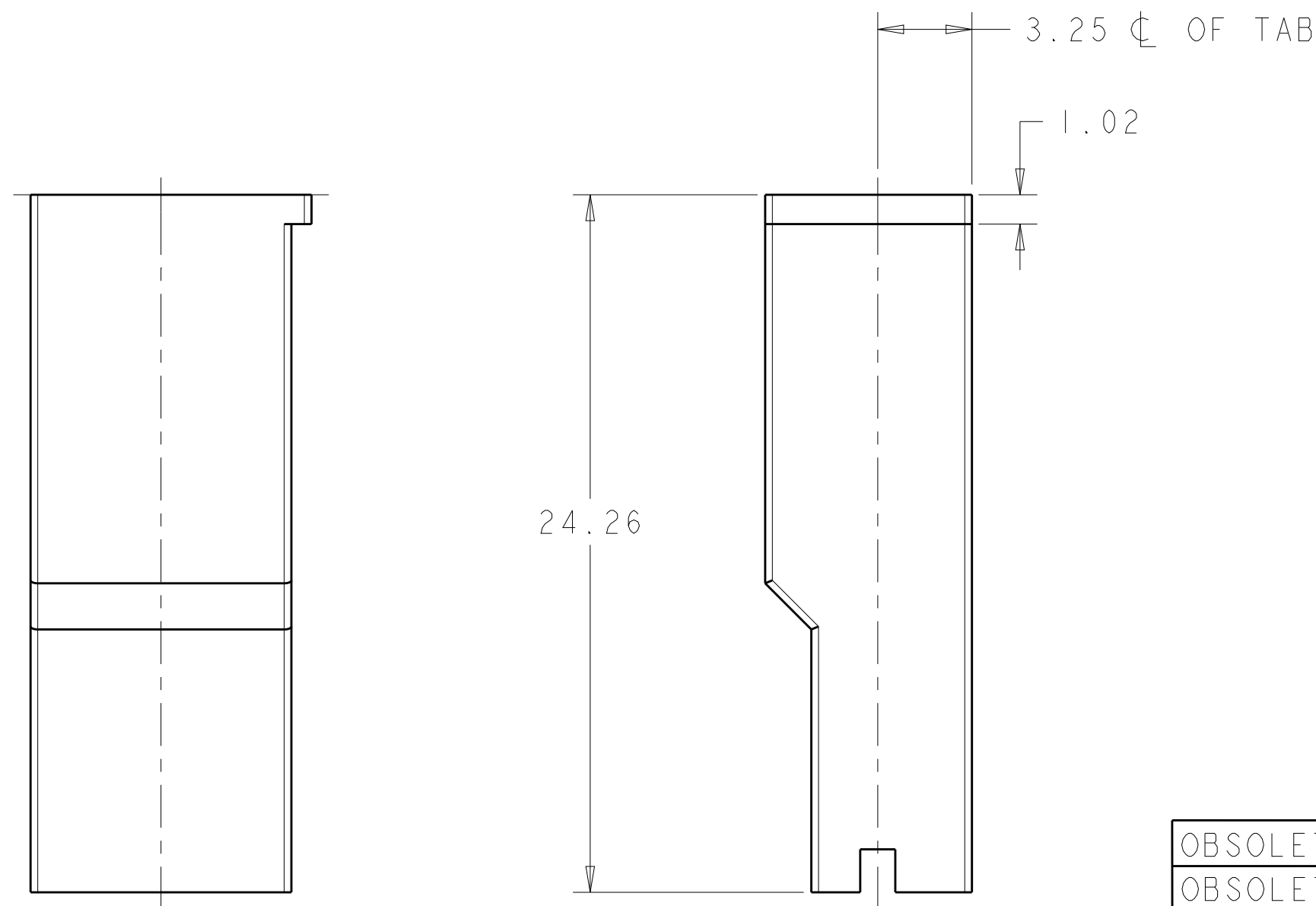

- NOTES:
- ① PA66 NATURAL MATERIAL ACC TO SPEC IEC 60335-1 GWT 750° WITHOUT FLAME
 - ② MOISTURISED PRODUCT FOR SMALL WIRE APPLICATIONS
 - ③ ONLY FOR USE WITH POST PLATED OR WASHED CONTACTS
 - ④ RIB IS EXTEND TO FRONT OF HOUSING FOR BRAZIL PRODUCTION
 - ⑤ USING EQUIVALENT ALTERNATE MATERIAL
 - ⑥ OBSOLETE PART

OBSOLETE	②	8-154719-6	As Drg	UL 94 V0	PA 66	Orange
OBSOLETE	② ⑥	8-154719-5	As Drg	UL 94 V2	PA 6/6 or Equivalent	Natural
OBSOLETE	①	8-154719-4	As Drg	UL 94 V0	PA 66	Natural
		8-154719-3	As Drg.	UL 94 V0	PA 66/6	Terracotta
OBSOLETE	②	8-154719-1	As Drg.	UL 94 V2	PA 6/6 or Equivalent	Black
		8-154719-0	As drg.	UL 94 V0	PA 6/6 or Equivalent	Clear
		7-154719-0	AE	UL 94 V0	PA 66	Orange (Ral 2000)
		6-154719-6	AB	UL 94 V2	PBT	Black
		5-154719-0	AB	UL 94 V0	PPE+PS	Orange
		4-154719-0	AA	UL 94 V0	PA 66	(Bk-59 Black)
	③	2-154719-0	AA	UL 94 V0	PPE+PS	Red
	⑤	1-154719-1	As Drg.	UL 94 V0	PA 6/6 or Equivalent	Natural
		1-154719-0	AE	UL 94 V0	PA 6/6 or Equivalent	Natural
		154719-9	As Drg.	UL 94 V2	PA 6/6 or Equivalent	Brown
		154719-6	As Drg.	UL 94 V2	PA 6/6 or Equivalent	Blue
		154719-5	As Drg.	UL 94 V2	PA 6/6 or Equivalent	Green
		154719-4	As Drg.	UL 94 V2	PA 6/6 or Equivalent	Yellow
		154719-2	As Drg.	UL 94 V2	PA 6/6 or Equivalent	Red
		154719-1	As Drg.	UL 94 V2	PA 6/6 or Equivalent	Natural
		154719	As. Drg.	UL 94 V2	PA 6/6 or Equivalent	Black
Notes	Part Number	Part Revision	Flammability Rating	Material	Colour	

THIS DRAWING IS A CONTROLLED DOCUMENT.

DWN: A. J. BEKEN 09MAY2002
 CHK: S. CLAPPISON 09MAY2002
 APVD: S. CLAPPISON 09MAY2002

STE TE Connectivity

NAME: POSITIVE LOCK RECEPTACLE INSULATOR

PRODUCT SPEC: 108-3252
 APPLICATION SPEC: 114-2153

SIZE: A2 CAGE CODE: 00779 DRAWING NO: C-154719
 WEIGHT: 0.5g

Customer Drawing SCALE: 5:1 SHEET 1 OF 1 REV: AV6