

THIS DRAWING IS UNPUBLISHED.

RELEASED FOR PUBLICATION

20

© COPYRIGHT 20 BY -

ALL RIGHTS RESERVED.

REVISIONS

P	LTR	DESCRIPTION	DATE	DWN	APVD
	A	INITIAL RELEASE	16APR2015	DL	CW

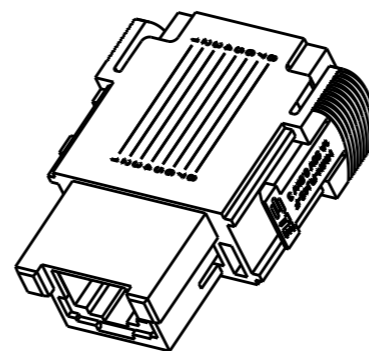
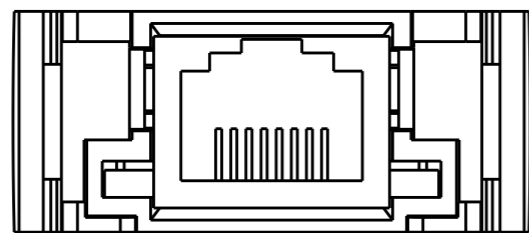

SCALE 1:1

NOTES:

- TECHNICAL CHARACTERISTICS:
 INSULATION MATERIAL: PC
 RATED VOLTAGE: 50V
 RATED CURRENT: 1A
 INSULATION RESISTANCE: $\geq 400M\Omega$
 RATED IMPULSE VOLTAGE: 0.8KV
 POLLUTION DEGREE: 3
 FLAMMABILITY: UL94V-0
 MATING CYCLES: 750
 OPERATION TEMPERATURE: $-40^{\circ}C \sim +70^{\circ}C$

注释:

- 技术参数:
 绝缘材料: PC
 额定电压: 50V
 额定电流: 1A
 绝缘电阻: $\geq 400M\Omega$
 脉冲电压: 0.8KV
 污染等级: 3
 阻燃等级: UL94V-0
 插拔次数: 750
 工作温度: $-40^{\circ}C \sim +70^{\circ}C$

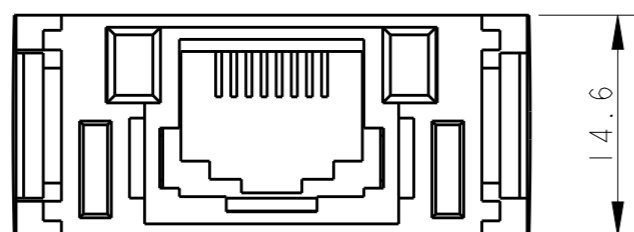
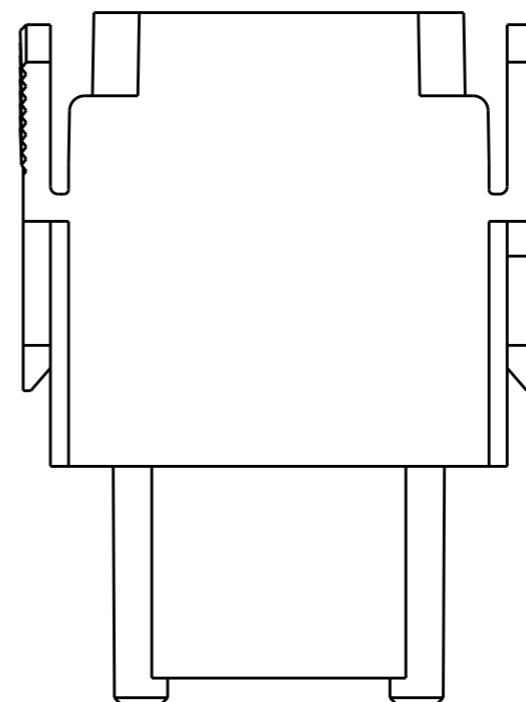
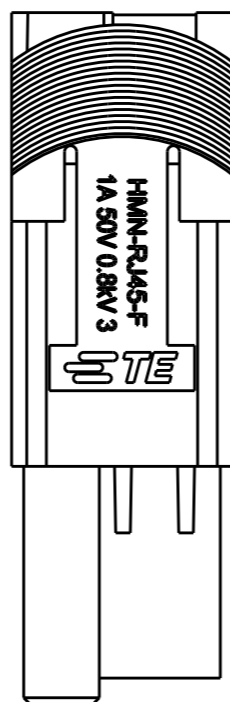
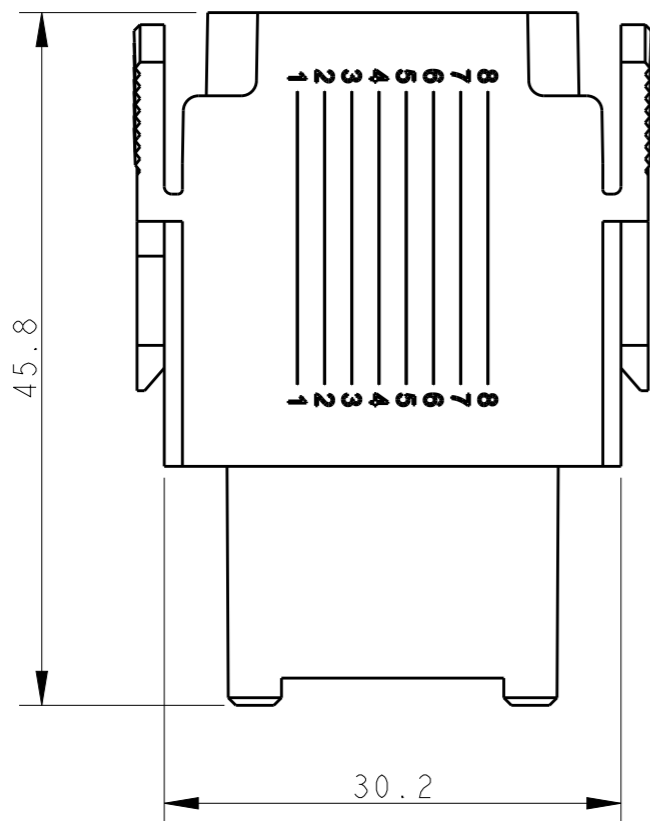
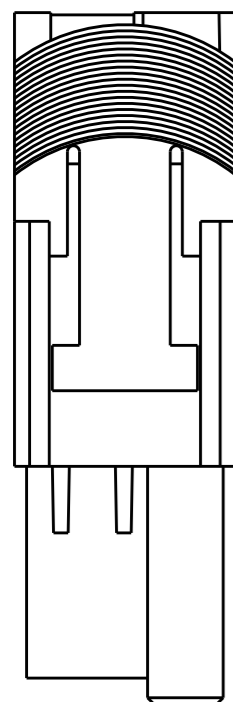

HMN-RJ45-F	T2113000201-000
DESCRIPTION	PART NUMBER

THIS DRAWING IS A CONTROLLED DOCUMENT.

DIMENSIONS:	TOLERANCES UNLESS OTHERWISE SPECIFIED:
mm	
	0 PLC \pm
	1 PLC \pm
	2 PLC \pm
	3 PLC \pm
	4 PLC \pm
	ANGLES \pm
MATERIAL	FINISH
-	-
-	-

DWN	DAVID LI	16APR2015
CHK	CHRIS WANG	16APR2015
APVD	XU XIANG	16APR2015
PRODUCT SPEC	108-137065	
APPLICATION SPEC	114-137065	
WEIGHT	-	
CUSTOMER DRAWING		

		TE Connectivity	
		NAME	
HMN-RJ45-F		RESTRICTED TO	
SIZE	CAGE CODE	DRAWING NO	RESTRICTED TO
A3	-	©-T2113000201000	-
SCALE		SHEET	REV
2:1		1 OF 1	A