

THIS DRAWING IS UNPUBLISHED.

RELEASED FOR PUBLICATION

20

© COPYRIGHT 20 BY -

ALL RIGHTS RESERVED.

REVISIONS

P	LTR	DESCRIPTION	DATE	DWN	APVD
	A	INITIAL RELEASE	16APR2015	DL	CW

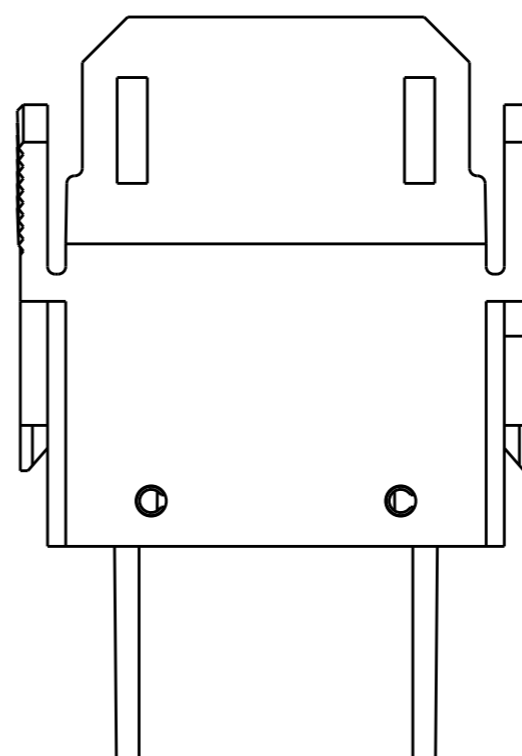
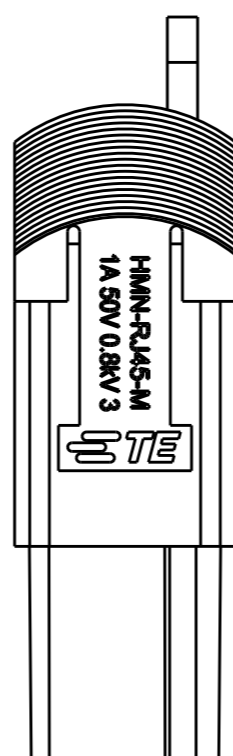
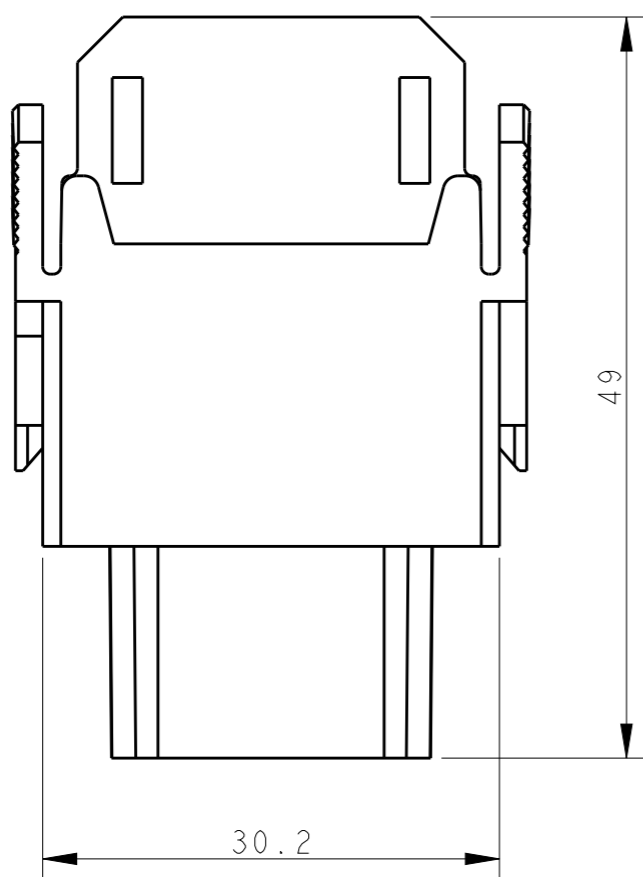
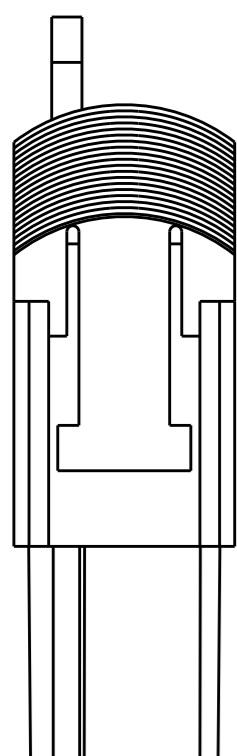
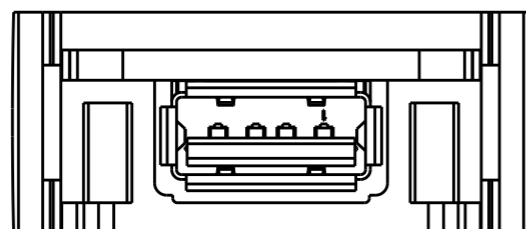

NOTES:

- TECHNICAL CHARACTERISTICS:
 INSULATION MATERIAL: PC
 RATED VOLTAGE: 50V
 RATED CURRENT: 1A
 INSULATION RESISTANCE: $\geq 400M\Omega$
 RATED IMPULSE VOLTAGE: 0.8KV
 POLLUTION DEGREE: 3
 FLAMMABILITY: UL94V-0
 MATING CYCLES: 1500
 OPERATION TEMPERATURE: $-40^{\circ}C \sim +70^{\circ}C$

注释:

- 技术参数:
 绝缘材料: PC
 额定电压: 50V
 额定电流: 1A
 绝缘电阻: $\geq 400M\Omega$
 脉冲电压: 0.8KV
 污染等级: 3
 阻燃等级: UL94V-0
 插拔次数: 1500
 工作温度: $-40^{\circ}C \sim +70^{\circ}C$

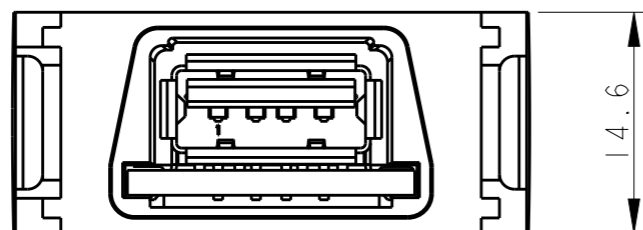

THIS DRAWING IS A CONTROLLED DOCUMENT.

DIMENSIONS:

mm

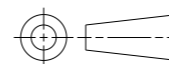

TOLERANCES UNLESS OTHERWISE SPECIFIED:

0 PLC	±-
1 PLC	±-
2 PLC	±-
3 PLC	±-
4 PLC	±-
ANGLES	±-

MATERIAL

-

FINISH

-

DWN 16APR2015

DAVID LI

CHK 16APR2015

CHRIS WANG

APVD 16APR2015

XU XIANG

PRODUCT SPEC

108-137066

APPLICATION SPEC

114-137066

WEIGHT

-

CUSTOMER DRAWING

HMN-USB-F	T2114000201-000
DESCRIPTION	PART NUMBER



NAME HMN-USB-F

SIZE A3 CAGE CODE - DRAWING NO. T2114000201000 RESTRICTED TO -

SCALE 2:1 SHEET 1 OF 1 REV A