

Non EMC DIN-Based VectorPak™ Subracks



ELECTRONICS & TECHNOLOGY, INC.
A FINE TECHNOLOGY GROUP

Front Panels

Screw-mounted front panel kits include handle and identification panel. Available in 3U, 6U and 9U heights and in two widths: 4HP (0.788") and 8HP (1.588"). All mounting hardware, including board mounting support bracket and hardware also included. Brushed aluminum panel with clear irridite plating matches standard finish for Vector packaging products. FPE04-6U panel will have extra center mounting holes for optional 'L' brackets. For no center holes order FPE04-6UB.

| Part # Ejector | Part # Fixed | Ht. | HP | A | B |
|----------------|--------------|-----|-----|----------------|---------------|
| FPE04-3U | FP04-3U | 3U | 4HP | 5.06" (129mm) | 0.788" (20mm) |
| FPE08-3U | FP08-3U | 3U | 8HP | 5.06" (129mm) | 1.588" (40mm) |
| FPE03-6U | FP03-6U | 6U | 3HP | 10.31" (262mm) | 0.580" (14mm) |
| FPE04-6U | FP04-6U | 6U | 4HP | 10.31" (262mm) | 0.788" (20mm) |
| FPE08-6U | FP08-6U | 6U | 8HP | 10.31" (262mm) | 1.588" (40mm) |

6U FRONT PANEL ASSEMBLY (WITH FIXED HANDLES)

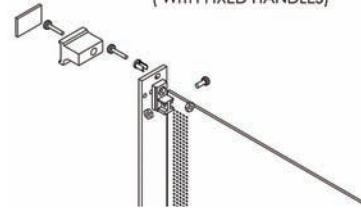

Type V 6U

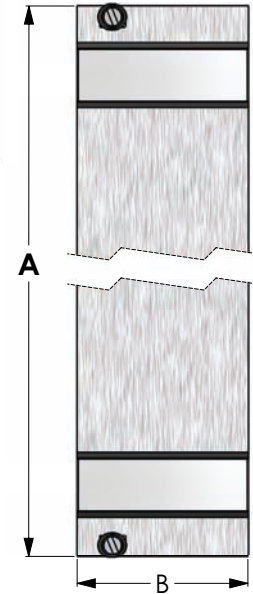

Type I, II Ejector Style

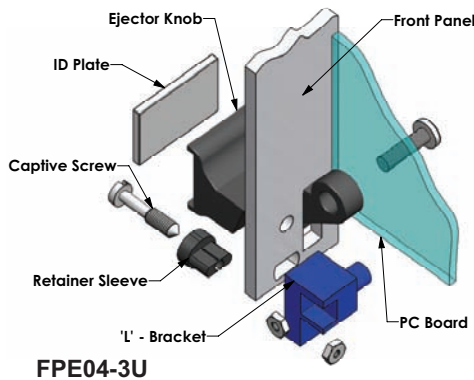

Type V, 3U Fixed Handle Style

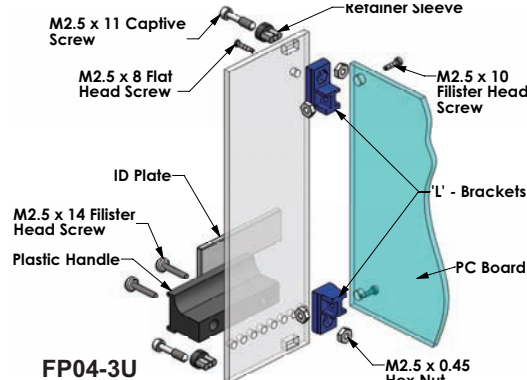

Standard Filler Panels

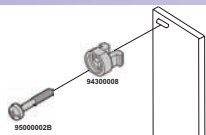

Captive sleeves/screws are included with all VectorPak™ filler panels and also sold separately in a hardware kit:

P/N HD99

| Includes | Qty |
|---|-----|
| Black plastic sleeve | 48 |
| M2.5 x 11 mm, nickel plated steel screw | 48 |

Filler Panels/Blank-off Plates Features

- Covers unused slots
- Improves air flow
- Mounting hardware included

Typical slot width is 0.800" (4HP)
Material: 6063T5, extruded brushed Aluminum with clear Iridite finish.

Each Filler Panel Kit Includes
4,8 or 12HP panel (0.8", 1.6" or 2.4")
M2.5 Nickel plated mounting screws with 'captive' sleeves

| U | Part Number 4HP | Part Number 8HP | Part Number 12HP |
|---|-----------------|-----------------|------------------|
| 3 | 5231304-07 | 5231308-07 | 5231312-07 |
| 6 | 5261304-07 | 5261308-07 | 5261312-07 |
| 9 | 5291304-07 | 5291308-07 | 5291312-07 |

3U FILLER PANELS

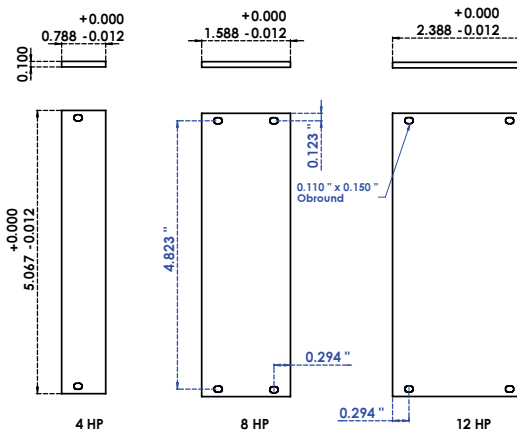

6U FILLER PANELS

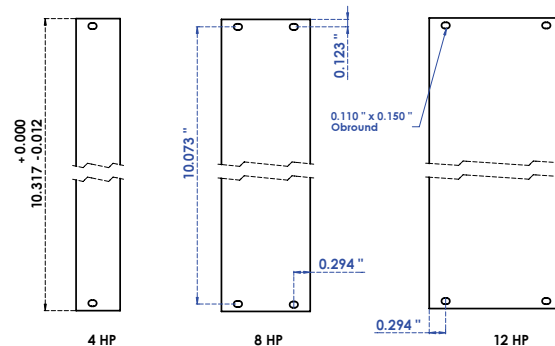

Non EMC
Subracks

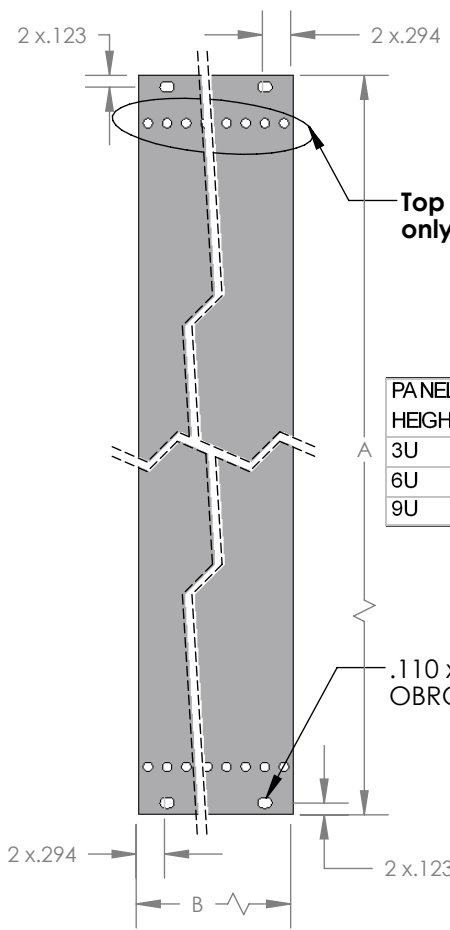

Top Handle
only for 6U & 9U

| PANEL HEIGHT | A |
|--------------|--------|
| 3U | 5.067 |
| 6U | 10.317 |
| 9U | 15.567 |

.110 x .150
OBROUND

| PANEL WIDTH | B |
|-------------|-------|
| 4 HP | 0.788 |
| 8 HP | 1.588 |
| 12 HP | 2.388 |

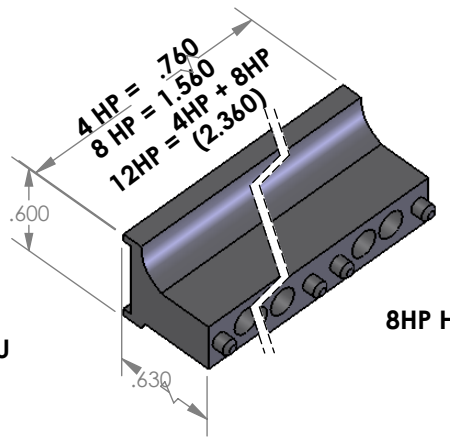

8HP Handle

4HP Handle

12HP ID Plate

Shown 12HP
Bottom Handle
Configuration

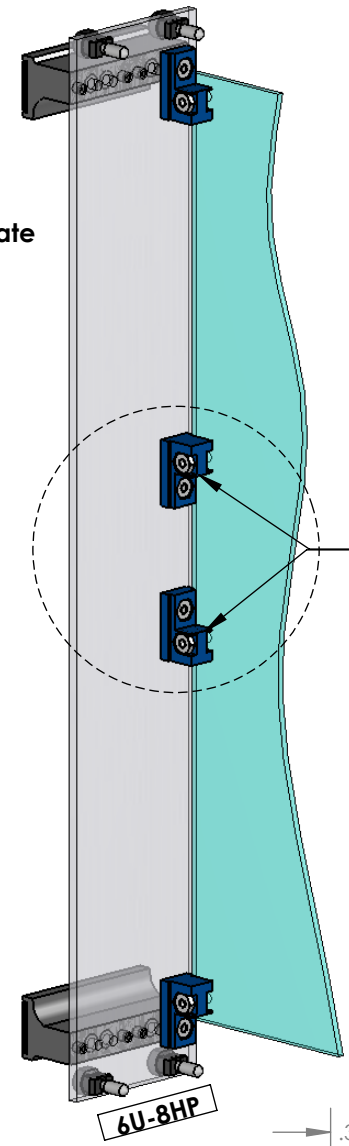

Optional
for 6U & 9U
High Panel
VECTOR P/N# HD102

M2.5 x 8 Flat
Head Screw

M2.5 x 10
Filister Head Screw

Retainer Sleeve

'L' Brackets

ID Plate

PC Board

M2.5 x 14
Filister Head Screw

Washer

Plastic Handle

M2.5 x 11
Captive Screw

M2.5 x 0.45
Hex Nut

3U-8HP

6U-8HP

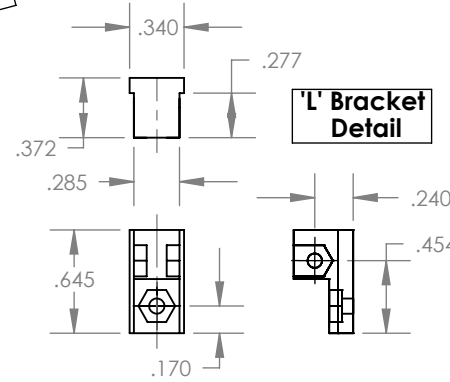

'L' Bracket
Detail