

Aluminum Capacitors + 85 °C, Snap-In

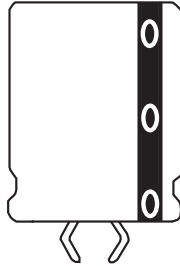

Fig.1 Component Outlines

FEATURES

- General purpose
- Polarized aluminum electrolytic capacitors, non-solid electrolyte
- High ripple capability
- Compliant to RoHS Directive 2002/95/EC



RoHS
COMPLIANT

QUICK REFERENCE DATA	
DESCRIPTION	VALUE
Nominal case size Ø D x L in inches (mm)	1.38 x 3.15 (35.0 x 80.0)
Operating temperature	- 40 °C to + 85 °C
Rated capacitance range, C _R	82 µF to 56 000 µF
Tolerance on C _R	- 10 %, + 30 %
Rated voltage range, U _R	6.3 WV _{DC} to 250 WV _{DC}
Termination	Snap mount
Life validation test 2000 h at 85 °C	ΔCAP ≤ 15 % from initial measurement. ΔESR ≤ 1.5 x initial specified limit. ΔDCL ≤ initial specified limit
Shelf life 500 h at 85 °C	ΔCAP ≤ 15 % from initial measurement. ΔESR ≤ 1.3 x initial specified limit. ΔDCL ≤ 2 x initial specified limit
DC leakage current	$I = K\sqrt{CV}$ K = 4.0 at + 25 °C I in µA, C in µF, V in Volts

RIPPLE CURRENT MULTIPLIERS			
TEMPERATURE			
AMBIENT TEMPERATURE		MULTIPLIERS	
- 55 °C		2.0	
- 65 °C		1.7	
- 75 °C		1.4	
- 85 °C		1.0	
FREQUENCY (Hz)			
WV _{DC}	50 TO 60	300 TO 1000	1000 AND UP
0 to 49	0.85	1.10	1.15
50 to 199	0.83	1.15	1.20
200 to 250	0.80	1.30	1.40
ESL (TYPICAL VALUES AT 1 MHz TO 10 MHz)			
Nominal Diameter	0.984 (25.0)	1.18 (30.0)	1.38 (35.0)
Typical ESL (nH)	8.0	10.0	12.0

DIMENSIONS in inches (millimeters)									
CASE CODE	DIAMETER		LENGTH		CASE CODE	DIAMETER		LENGTH	
	D + 0.039 - 0 (+ 1.0 - 0)		L ± 0.079 (2.0)			D + 0.039 - 0 (+ 1.0 - 0)		L ± 0.079 (2.0)	
JA	1.00 (25.0)		1.00 (25.0)		KD	1.18 (30.0)		1.57 (40.0)	
JB	1.00 (25.0)		1.18 (30.0)		KE	1.18 (30.0)		2.00 (50.0)	
JC	1.00 (25.0)		1.38 (35.0)		MB	1.38 (35.0)		1.18 (30.0)	
JD	1.00 (25.0)		1.57 (40.0)		MC	1.38 (35.0)		1.38 (35.0)	
JE	1.00 (25.0)		2.00 (50.0)		MD	1.38 (35.0)		1.57 (40.0)	
KA	1.18 (30.0)		1.00 (25.0)		ME	1.38 (35.0)		2.00 (50.0)	
KB	1.18 (30.0)		1.18 (30.0)		MF	1.38 (35.0)		2.50 (63.0)	
KC	1.18 (30.0)		1.38 (35.0)		MG	1.38 (35.0)		3.18 (80.0)	

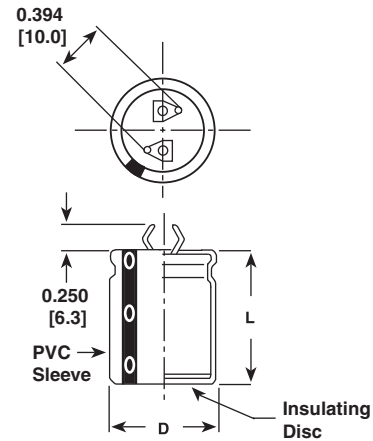
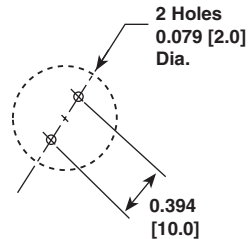
DIMENSIONAL AND AVAILABLE FORMS
STYLE D

ORDERING EXAMPLE

Electrolytic capacitor 80D series: 80D122P200ME2DE3

DESCRIPTION

CODE	EXPLANATION
80D	Product type
122	Capacitance value (1200 μ F)
P	Tolerance (P = - 10 %/+ 30 %)
200	Voltage rating at 85 °C (200 V)
ME	Can size (see dimensions table)
2	PVC insulating sleeve
D	Terminal style (D = 2 pin snap-in)
E3	RoHS compliant

ELECTRICAL DATA AND ORDERING INFORMATION

CAPACITANCE (μ F)	PART NUMBER	NOMINAL CASE SIZE D x L	MAX. ESR (Ω)		MAX. RIPPLE at + 85 °C (A)	
			120 Hz	10 kHz to 40 kHz	120 Hz	10 kHz to 40 kHz
16 WV_{DC} at + 85 °C, SURGE = 20 V						
8200.0	80D822P016JB2DE3	0.984 x 1.18 (25.0 x 30.0)	73.0	65.0	3.3	3.6
8200.0	80D822P016KA2DE3	1.18 x 0.984 (30.0 x 25.0)	91.0	84.0	2.8	3.0
10 000.0	80D103P016JC2DE3	0.984 x 1.38 (25.0 x 35.0)	59.0	53.0	3.9	4.2
15 000.0	80D153P016JE2DE3	0.984 x 1.97 (25.0 x 50.0)	37.0	33.0	5.6	6.0
22 000.0	80D223P016KE2DE3	1.18 x 1.97 (30.0 x 50.0)	35.0	32.0	5.8	6.1
33 000.0	80D333P016ME2DE3	1.38 x 1.97 (35.0 x 50.0)	19.0	17.0	9.4	10.0
25 WV_{DC} at + 85 °C, SURGE = 30 V						
4700.0	80D472P025JB2DE3	0.984 x 1.18 (25.0 x 30.0)	76.0	65.0	3.2	3.6
6800.0	80D682P025KB2DE3	1.18 x 1.18 (30.0 x 30.0)	71.0	63.0	3.4	3.6
10 000.0	80D103P025JE2DE3	0.984 x 1.97 (25.0 x 50.0)	39.0	33.0	5.4	6.0
10 000.0	80D103P025MB2DE3	1.38 x 1.18 (35.0 x 30.0)	38.0	33.0	5.5	6.2
15 000.0	80D153P025KE2DE3	1.18 x 1.97 (30.0 x 50.0)	36.0	32.0	5.7	6.1
22 000.0	80D223P025ME2DE3	1.38 x 1.97 (35.0 x 50.0)	19.0	17.0	9.1	10.0

ELECTRICAL DATA AND ORDERING INFORMATION						
CAPACITANCE (μF)	PART NUMBER	NOMINAL CASE SIZE D x L	MAX. ESR (Ω)		MAX. RIPPLE at + 85 °C (A)	
			120 Hz	10 kHz to 40 kHz	120 Hz	10 kHz to 40 kHz
35 WV_{DC} at + 85 °C, SURGE = 44 V						
6800.0	80D682P035KC2DE3	1.18 x 1.38 (30.0 x 35.0)	60.0	51.0	3.8	4.2
10 000.0	80D103P035MC2DE3	1.38 x 1.38 (35.0 x 35.0)	33.0	27.0	6.2	7.2
12 000.0	80D123P035KE2DE3	1.18 x 1.97 (30.0 x 50.0)	33.0	27.0	6.2	7.2
15 000.0	80D153P035ME2DE3	1.38 x 1.97 (35.0 x 50.0)	20.0	17.0	8.8	10.0
50 WV_{DC} at + 85 °C, SURGE = 63 V						
3300.0	80D332P050JD2DE3	0.984 x 1.57 (25.0 x 40.0)	57.0	42.0	3.9	4.9
3300.0	80D332P050KB2DE3	1.18 x 1.18 (30.0 x 30.0)	79.0	63.0	3.1	3.6
4700.0	80D472P050KD2DE3	1.18 x 1.57 (30.0 x 40.0)	51.0	41.0	4.3	4.9
6800.0	80D682P050KE2DE3	1.18 x 1.97 (30.0 x 50.0)	40.0	32.0	5.3	6.1
63 WV_{DC} at + 85 °C, SURGE = 79 V						
1500.0	80D152P063JB2DE3	0.984 x 1.18 (25.0 x 30.0)	82.0	55.0	2.8	3.8
2200.0	80D222P063KB2DE3	1.18 x 1.18 (30.0 x 30.0)	72.0	54.0	3.2	3.9
3300.0	80D332P063MB2DE3	1.38 x 1.18 (35.0 x 30.0)	40.0	28.0	5.0	6.6
4700.0	80D472P063KE2DE3	1.18 x 1.97 (30.0 x 50.0)	36.0	28.0	5.4	6.4
6800.0	80D682P063ME2DE3	1.38 x 1.97 (35.0 x 50.0)	21.0	15.0	8.3	10.0
100 WV_{DC} at + 85 °C, SURGE = 125 V						
680.0	80D681P100JB2DE3	0.984 x 1.18 (25.0 x 30.0)	139.0	85.0	2.2	3.5
1000.0	80D102P100KB2DE3	1.18 x 1.18 (30.0 x 30.0)	111.0	74.0	2.7	3.7
1500.0	80D152P100JE2DE3	0.984 x 1.97 (25.0 x 50.0)	68.0	42.0	3.9	5.9
2200.0	80D222P100KE2DE3	1.18 x 1.97 (30.0 x 50.0)	55.0	37.0	4.7	6.2
3300.0	80D332P100ME2DE3	1.38 x 1.97 (35.0 x 50.0)	50.0	37.0	5.2	6.2
200 WV_{DC} at + 85 °C, SURGE = 250 V						
150.0	80D151P200JA2DE3	0.984 x 0.984 (25.0 x 25.0)	660.0	375.0	1.3	3.2
220.0	80D221P200KA2DE3	1.18 x 0.984 (30.0 x 25.0)	460.0	272.0	1.7	3.6
330.0	80D331P200KC2DE3	1.18 x 1.38 (30.0 x 35.0)	278.0	165.0	2.4	4.9
470.0	80D471P200KD2DE3	1.18 x 1.57 (30.0 x 40.0)	220.0	131.0	2.8	5.7
680.0	80D681P200KD2DE3	1.18 x 1.57 (30.0 x 40.0)	248.0	127.0	2.1	4.7
820.0	80D821P200ME2DE3	1.38 x 1.97 (35.0 x 50.0)	130.0	82.0	4.3	7.4
1000.0	80D102P200ME2DE3	1.38 x 1.97 (35.0 x 50.0)	144.0	81.0	3.4	6.6
1200.0	80D122P200ME2DE3	1.38 x 1.97 (35.0 x 50.0)	141.0	75.0	3.4	6.6
250 WV_{DC} at + 85 °C, SURGE = 300 V						
100.0	80D101P250JA2DE3	0.984 x 0.984 (25.0 x 25.0)	720.0	377.0	1.1	3.2
150.0	80D151P250JB2DE3	0.984 x 1.18 (25.0 x 30.0)	541.0	284.0	1.4	3.8
220.0	80D221P250JD2DE3	0.984 x 1.57 (25.0 x 40.0)	343.0	182.0	2.0	5.2
330.0	80D331P250JE2DE3	0.984 x 1.97 (25.0 x 50.0)	263.0	140.0	2.5	6.3
470.0	80D471P250KE2DE3	1.18 x 1.97 (30.0 x 50.0)	185.0	101.0	3.2	7.0
680.0	80D681P250ME2DE3	1.38 x 1.97 (35.0 x 50.0)	191.0	81.0	4.0	7.4



Disclaimer

ALL PRODUCT, PRODUCT SPECIFICATIONS AND DATA ARE SUBJECT TO CHANGE WITHOUT NOTICE TO IMPROVE RELIABILITY, FUNCTION OR DESIGN OR OTHERWISE.

Vishay Intertechnology, Inc., its affiliates, agents, and employees, and all persons acting on its or their behalf (collectively, "Vishay"), disclaim any and all liability for any errors, inaccuracies or incompleteness contained in any datasheet or in any other disclosure relating to any product.

Vishay makes no warranty, representation or guarantee regarding the suitability of the products for any particular purpose or the continuing production of any product. To the maximum extent permitted by applicable law, Vishay disclaims (i) any and all liability arising out of the application or use of any product, (ii) any and all liability, including without limitation special, consequential or incidental damages, and (iii) any and all implied warranties, including warranties of fitness for particular purpose, non-infringement and merchantability.

Statements regarding the suitability of products for certain types of applications are based on Vishay's knowledge of typical requirements that are often placed on Vishay products in generic applications. Such statements are not binding statements about the suitability of products for a particular application. It is the customer's responsibility to validate that a particular product with the properties described in the product specification is suitable for use in a particular application. Parameters provided in datasheets and/or specifications may vary in different applications and performance may vary over time. All operating parameters, including typical parameters, must be validated for each customer application by the customer's technical experts. Product specifications do not expand or otherwise modify Vishay's terms and conditions of purchase, including but not limited to the warranty expressed therein.

Except as expressly indicated in writing, Vishay products are not designed for use in medical, life-saving, or life-sustaining applications or for any other application in which the failure of the Vishay product could result in personal injury or death. Customers using or selling Vishay products not expressly indicated for use in such applications do so at their own risk and agree to fully indemnify and hold Vishay and its distributors harmless from and against any and all claims, liabilities, expenses and damages arising or resulting in connection with such use or sale, including attorneys fees, even if such claim alleges that Vishay or its distributor was negligent regarding the design or manufacture of the part. Please contact authorized Vishay personnel to obtain written terms and conditions regarding products designed for such applications.

No license, express or implied, by estoppel or otherwise, to any intellectual property rights is granted by this document or by any conduct of Vishay. Product names and markings noted herein may be trademarks of their respective owners.