

Industrial Ethernet IE-PCB-RJ45-THR-C6-SLM2

Weidmüller Interface GmbH & Co. KG
 Klingenbergstraße 16
 D-32758 Detmold
 Germany
 Fon: +49 5231 1429-0
 Fax: +49 5231 14292083
 www.weidmueller.com



IE plug-in connectors, IP20, for copper and fibre optic cables

General ordering data

Type	IE-PCB-RJ45-THR-C6-SLM2
Order No.	1534760000
Version	RJ45 PCB socket, 180°, THT/THR solder connection, IP20
GTIN (EAN)	4050118338423
Qty.	60 pc(s).
Packaging	Tray; Rs = 10 ⁹ - 10 ¹² Ω

Data sheet

Industrial Ethernet IE-PCB-RJ45-THR-C6-SLM2

Weidmüller Interface GmbH & Co. KG
 Klingenbergstraße 16
 D-32758 Detmold
 Germany
 Fon: +49 5231 1429-0
 Fax: +49 5231 14292083
 www.weidmueller.com

Technical data

Dimensions and weights

Net weight 6.433 g

Temperatures

Operating temperature -40 °C...85 °C Storage temperature
 Installation temperature

Electrical properties

Contact resistance	≤ 20 mΩ	Dielectric strength, contact / contact	≥ 1000 V DC
Insulation resistance	> 500 MΩ	Rated current	1.5 A
Rated voltage	125 V AC		

Material data

Insulating material	PA 9T	Insulating material group	II
CTI	≥ 500	UL 94 flammability rating	V-0
Contact material	Phosphorus bronze	Contact surface	Selective gold 30 μ"
Shielding material	Copper alloy	Shield surface	nickel-plated
Moisture Level (MSL)	1		

Standards

Connector standard IEC 60603-7-5 1 Certificate No. (UL) E471884

System parameters

Wiring	10-wire	Outgoing elbow	180°
Number of solder pins per pole	1	Mounting onto the PCB	THT/THR solder connection
Solder eyelet hole diameter (D)	0.9 mm	Solder eyelet hole diameter tolerance (D)	± 0.1 mm
Solder pin length (l)	3.2 mm	Solder pin dimensions	0.40 x 0.30 mm, LED pins = 0.50 x 0.50 mm
Pitch in inches (P)	0.05 inch	Pitch in mm (P)	1.27 mm
Insulation resistance	> 500 MΩ	No. of poles	10
Packaging	Tray; Rs = 10 ⁹ - 10 ¹² Ω	Pin series quantity	1
Plugging cycles	750	Protection degree	IP20
Shielding	Yes		

Classifications

ETIM 6.0	EC001121	eClass 6.2	27-25-05-04
eClass 7.1	27-25-05-04	eClass 8.1	19-17-01-25
eClass 9.0	19-17-01-25	eClass 9.1	27-44-09-90

Approvals

Approvals



ROHS Conform

**Industrial Ethernet
IE-PCB-RJ45-THR-C6-SLM2**

Weidmüller Interface GmbH & Co. KG
 Klingenbergstraße 16
 D-32758 Detmold
 Germany
 Fon: +49 5231 1429-0
 Fax: +49 5231 14292083
 www.weidmueller.com

Drawings

Dimensioned drawing

Dimensioned drawing

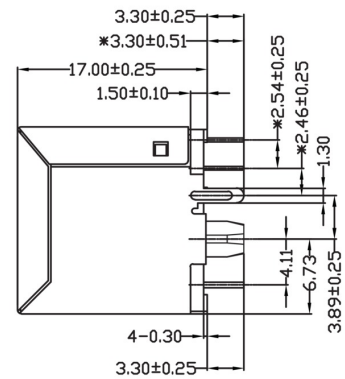

Dimensioned drawing

Dimensioned drawing

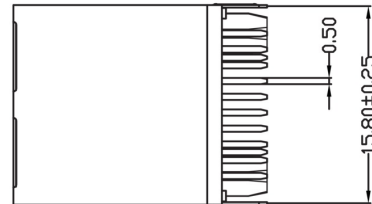
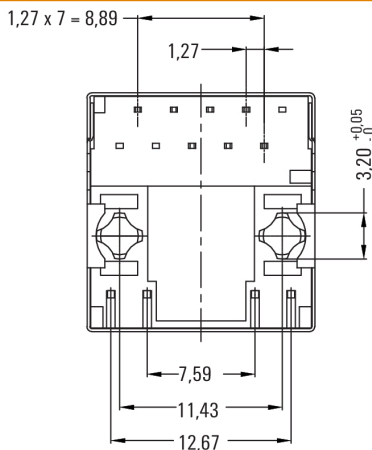

PCB design

Wiring diagram

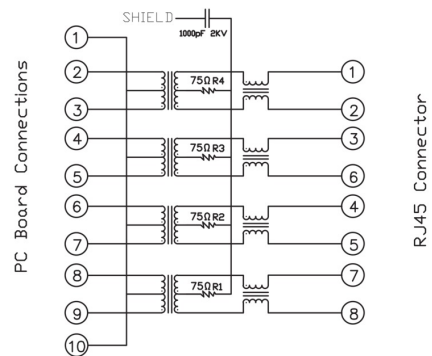
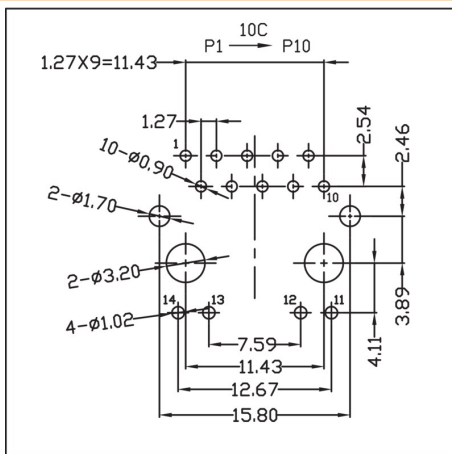

Recommended wave soldering profiles

Weidmüller Interface GmbH & Co. KG
 Klingenbergstraße 16
 D-32758 Detmold
 Germany
 Fon: +49 5231 14-0
 Fax: +49 5231 14-292083
 www.weidmueller.com

Single Wave:



Double Wave:

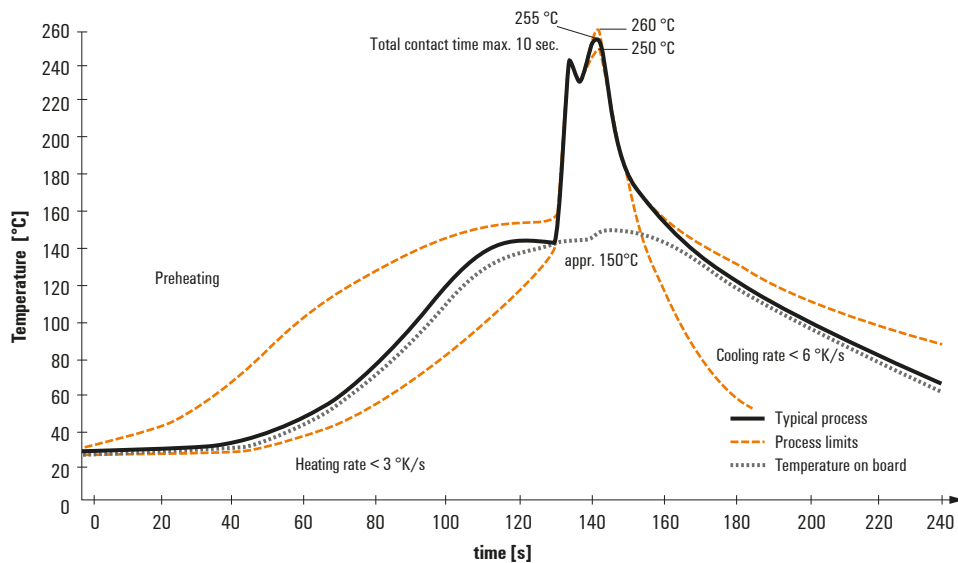

Wave soldering profiles

Wired connection elements should be processed in accordance with the DIN EN 61760-1 standard. We have included two recommendations for practical wave soldering profiles, with which Weidmüller PCB terminals and connectors are qualified.

When choosing a suitable profile for your application, the following factors also need to be considered:

- PCB thickness
- Proportion of Cu in the layers
- Single/double-sided assembly
- Product range
- Heating and cooling rates

The single and double wave profiles each indicate the recommended operating range, including the maximum soldering temperature of 260°C. In practice, the maximum soldering temperature is quite often well below the above maximum profile.

Recommended reflow soldering profile

Weidmüller Interface GmbH & Co. KG
 Klingenbergstraße 16
 D-32758 Detmold
 Germany
 Fon: +49 5231 14-0
 Fax: +49 5231 14-292083
 www.weidmueller.com



Reflow soldering profile

The perfect soldering profile for SMT Surface Mount Technology is one the most exiting question in SMT production. But there are more than one correct answer: The diagram of temperature-on-time is related to processing features of solder paste and to maximum load of components.

We have to consider the following parameters:

- Time for pre heating
- Maximum temperature
- Time above melting point
- Time for cooling
- Maximum heating rate
- Maximum cooling rate

We recommend a typical solder profile with associated process limits. With preheating components and board are prepared smoothly for the solder phase. Heating rate is typically $\leq +3\text{K/s}$. In parallel the solder paste is ‚activated‘. The time above melting point of 217°C the paste gets liquid and components and boards begin to connect. The maximum temperature of 245°C to 254°C should stay between 10 and 40 seconds. In the cooling phase at $\geq -6\text{K/s}$ solder is cured. Board and components cool down while avoiding cold cracks.