

RECOMMENDED PCB LAYOUT - COMPONENT VIEW

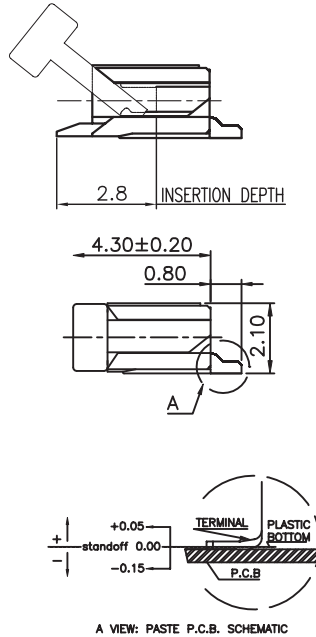

A VIEW: PASTE P.C.B. SCHEMATIC

MATERIAL:
 HOUSING MATERIAL: LCP
 COLOR: IVORY
 ACTUATOR MATERIAL: LCP
 COLOR: BLACK
 CONTACT MATERIAL: PHOSPOR BRONZE
 CONTACT PLATING: 100µ" TIN OVER 50µ" NI
 QUALITY CLASS: 25 MATING CYCLES*

ENVIRONMENTAL:
 OPERATING TEMPERATURE: -25°C UP TO 85°C
 FLAMABILITY RATING: UL94-V0
 COMPLIANCE: LEAD FREE AND ROHS

ELECTRICAL:
 CURRENT RATING: 0.5A
 WORKING VOLTAGE: 50V
 INSULATION RESISTANCE: >100MOHM
 DIELECTRIC WITHSTANDING VOLT.: 250VAC/MN
 CONTACT RESISTANCE: 20mOHM MAX

STANDARD
 CERTIFIED: E323964 / MODEL NUMBER 687
 FOLLOWED BY 1, FOLLOWED BY 04 THRU 50, FOLLOWED
 BY 140 OR 145, FOLLOWED BY NUMERIC DIGITS

SOLDERING:
 REFLOW PROCESS ONLY

DIMENSION:
 B = 0.5 x NB PINS + 6.4
 C = 0.5 x (NB PINS - 1)
 D = 0.5 x (NB PINS + 1) + 0.1
 E = 0.5 x (NB PINS + 1)

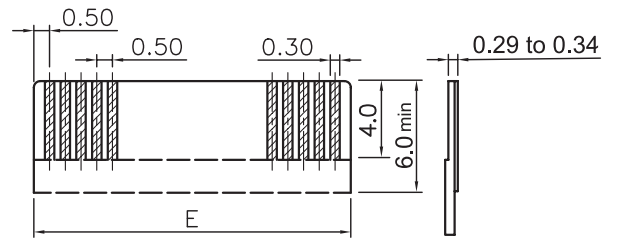

APPLICABLE FFC LAYOUT

RoHS Compliant		*NOTE: theoretical value related to the Tin plating; however, due to the sensitive actuator, we recommend not to make more than 1 or 2 cycles in order to maintain acceptable mechanical & electrical conditions			
				PROJECTION: 	GENERAL TOLERANCE .X = +/- 0.2 .XX = +/- 0.15
				APPROVAL: RJ	
I	13-DEC-13	TPK UPDATE	QL	UNIT: MM	DESCRIPTION: 0.5MM ZIF FPC HORIZONTAL BOTTOM CONTACT TYPE - TAPE & REEL PACKAGING
H	23-JAN-13	UNIT µ => µ"	QL	SCALE:	WERI PART NO: 6871 xx 14522
REV	DATE	FILE	BY	SHEET: 1/3	
				DRAW: PEARL	SIZE A4

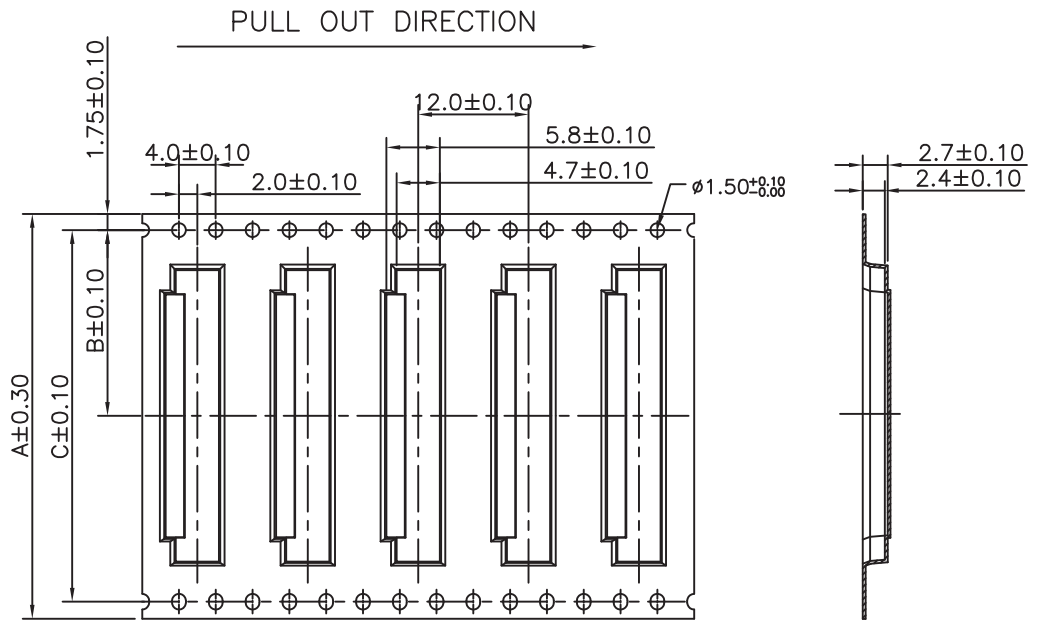
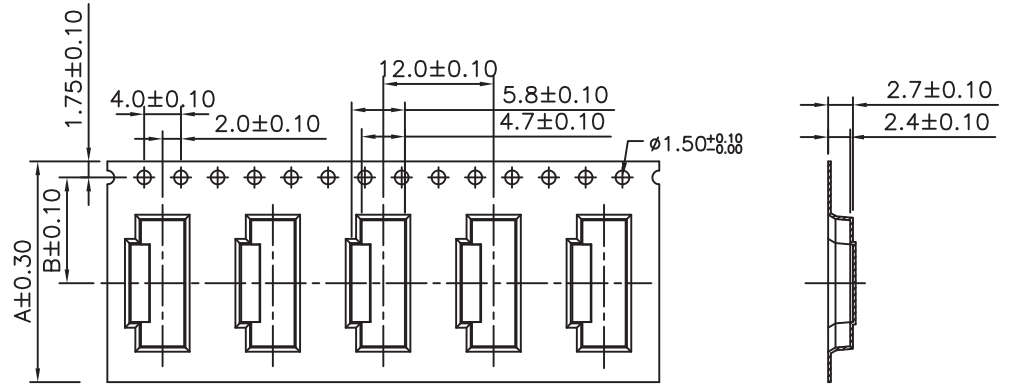
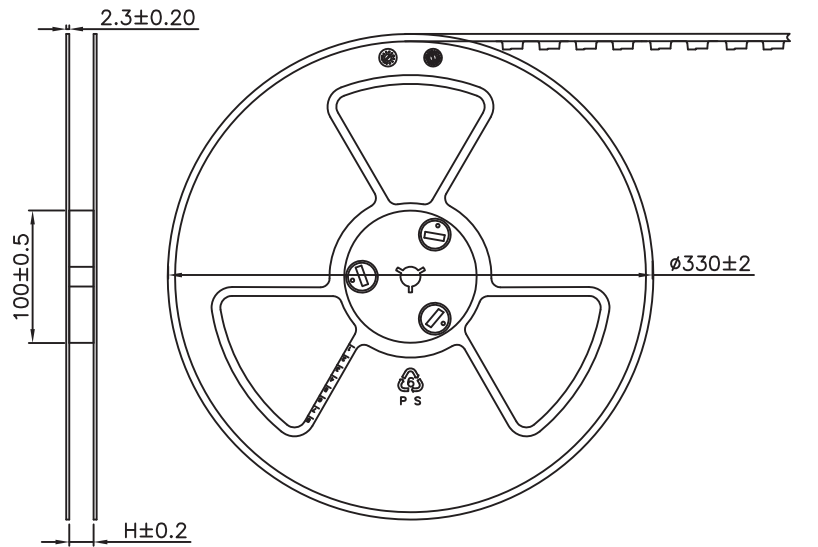

Dimension	4-6 PIN	8-20 PIN	22-30 PIN	32-50 PIN
A	16	24	32	44
B	7.5	11.5	14.2	20.2
C	/	/	28.4	40.4
H	16.5	24.5	32.5	44.5
REEL/CTN	9	7	5	4

RoHS Compliant				
G				
F				
E				
D				
C				
B				
A				
REV	DATE	FILE	BY	

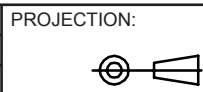

APPROVAL: RJ

GENERAL TOLERANCE
 .X = +/- 0.2
 .XX = +/- 0.15

UNIT: MM
 SCALE:
 SHEET: 2/3
 DRAW: PEARL



DESCRIPTION: 0.5MM ZIF FPC HORIZONTAL BOTTOM CONTACT TYPE - TAPE & REEL PACKAGING
 WERI PART NO: 6871 xx 14522

SIZE
A4

A

B

C

D

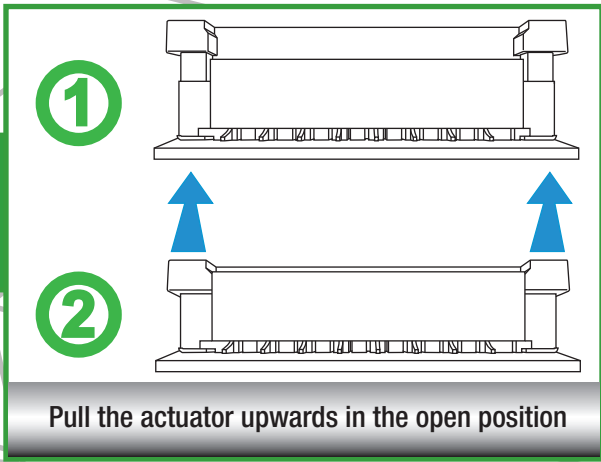

A

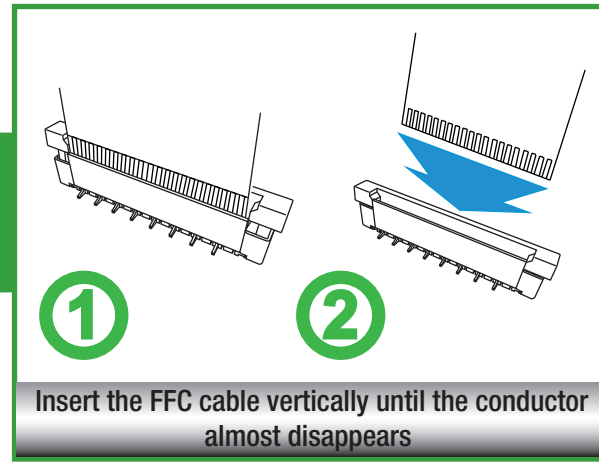

B

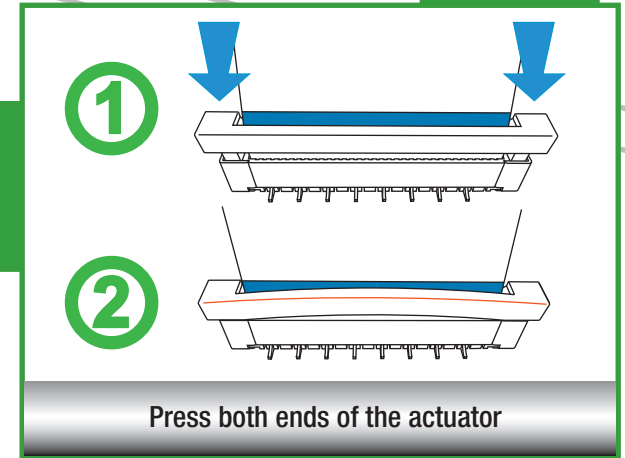
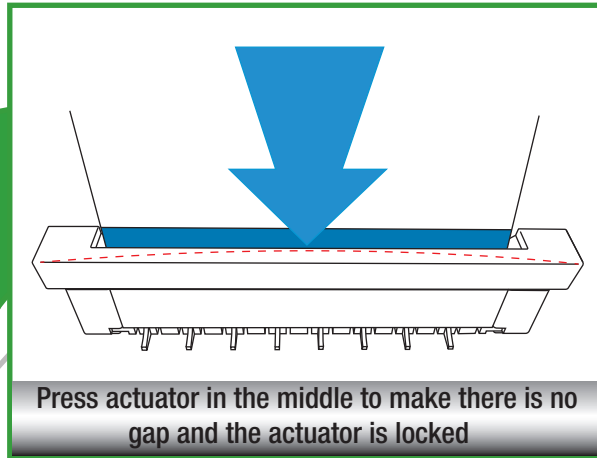

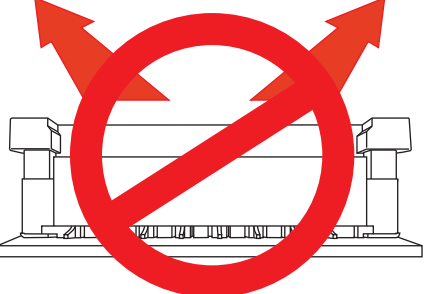

Pull the actuator as horizontally as possible by a proper force

A

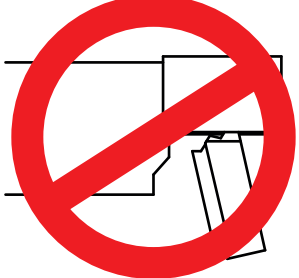

Do not pull the actuator too far otherwise the stop limit (hook on actuator) may be broken

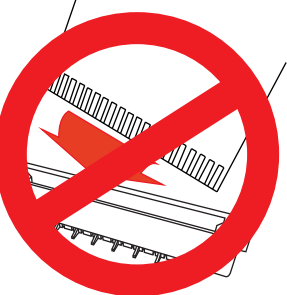

Do not keep FFC inclined when insertion

B

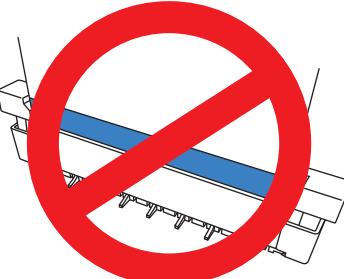

Don't keep conductor toward actuator