

DO NOT SCALE FROM THIS PRINT

DESIGNED AND DIMENSIONED IN MILLIMETERS [INCHES]
ALL DIMENSIONS REFERENCE EXCEPT AS SHOWN

ARF6-XX-X-RA-XR

NO OF PAIRS (TOTAL)
-08, -16, -24

PLATING SPECIFICATION
-S: 30μ" SELECTIVE GOLD IN CONTACT AREA, MATTE TIN ON TAIL
**-H: 30μ" SELECTIVE GOLD IN CONTACT AREA, FLASH AU ON TAIL

PACKAGING
-TR: TAPE & REEL (SEE NOTES 1 & 2)
-FR: FULL REEL QTY. TAPE & REEL (SEE NOTE 2)

ROW SPECIFICATION
-RA: RIGHT ANGLE

(** = NOT RELEASED)

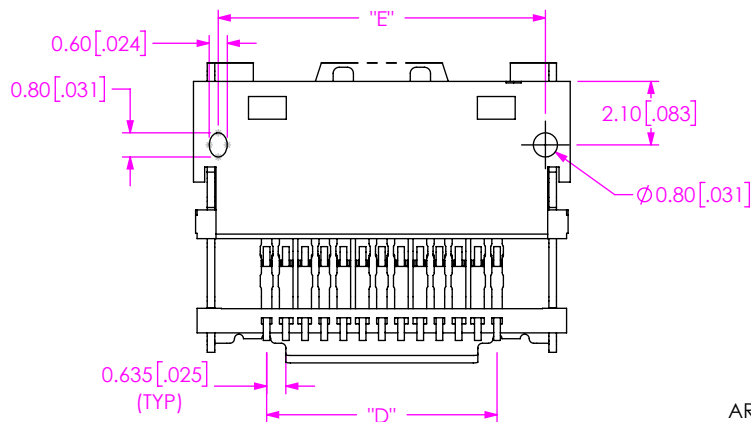
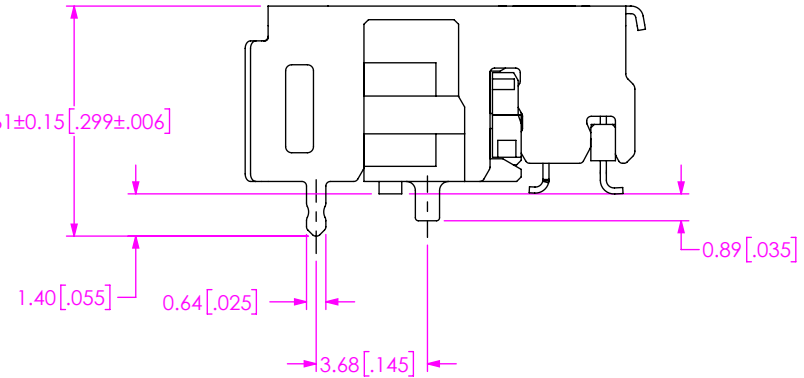
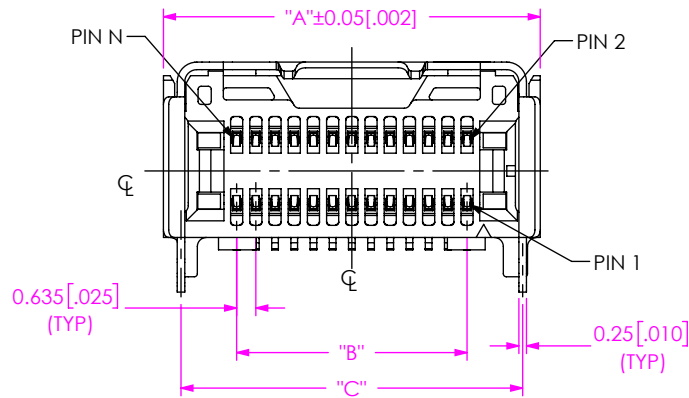
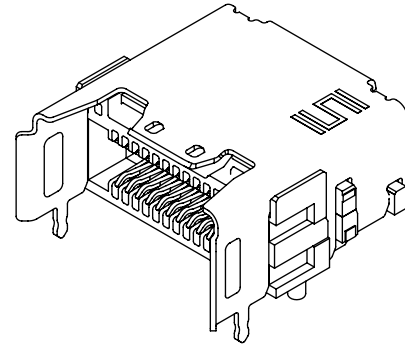
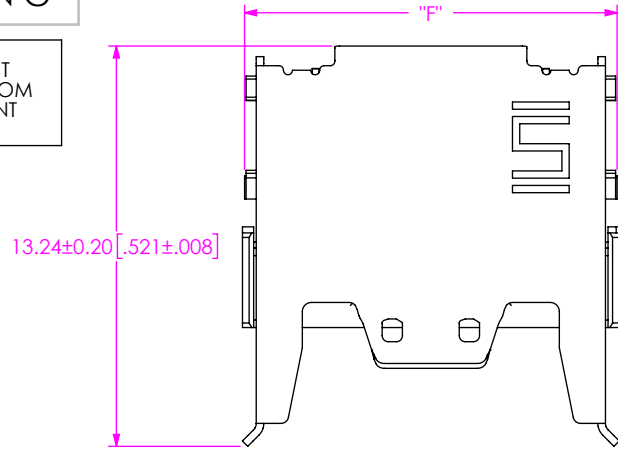

TABLE 2

No. OF PAIRS	N	N-1
-08	26	25
-16	50	49
-24	74	73

TABLE 1

NO OF PAIRS	"A"	"B"	"C"	"D"	"E"	"F"
-08	12.46 [0.491]	7.62 [0.300]	11.30 [0.445]	7.62 [0.300]	10.82 [0.426]	12.32 [0.485]
-16	20.08 [0.791]	15.24 [0.600]	18.92 [0.745]	15.24 [0.600]	18.44 [0.726]	19.94 [0.785]
-24	27.70 [1.091]	22.86 [0.900]	26.54 [1.045]	22.86 [0.900]	26.06 [1.026]	27.56 [1.085]

FIG 1
ARF6-08-X-RA SHOWN

NOTES:

- TAPE & REEL IS STANDARD PACKAGING.
- ORDERS WILL BE PACKAGED ACCORDING TO THE SAMTEC PACKAGING EFFICIENCY STANDARDS (SPES) FOUND ON WWW.SAMTEC.COM

PROPRIETARY NOTE
THIS DOCUMENT CONTAINS CONFIDENTIAL AND PROPRIETARY INFORMATION AND ALL DESIGN, MANUFACTURING, REPRODUCTION, USE, PATENT RIGHTS AND SALES RIGHTS ARE EXPRESSLY RESERVED BY SAMTEC, INC. THIS DOCUMENT SHALL NOT BE DISCLOSED, IN WHOLE OR PART, TO ANY UNAUTHORIZED PERSON OR ENTITY NOR REPRODUCED, TRANSFERRED OR INCORPORATED IN ANY OTHER PROJECT IN ANY MANNER WITHOUT THE EXPRESS WRITTEN CONSENT OF SAMTEC, INC.

DO NOT SCALE DRAWING
SHEET SCALE: 4:1

MATERIAL:
INSULATOR: LCP
CONTACT: COPPER ALLOY
SHIELD: PHOS BRONZE



520 PARK EAST BLVD. NEW ALBANY, IN 47150
PHONE: 812-944-6733 FAX: 812-948-5047
e-Mail info@SAMTEC.com code 55322

DESCRIPTION:
ACCELERATE-RA ASSEMBLY

DWG. NO.
ARF6-XX-X-RA-XR