

PATENT NUMBERS
5713755/5961339

BKT-1XX-XX-XX-V-XX-X-XX

PACKAGING
BLANK: TUBES (SEE NOTE 6)
-TR: TAPE & REEL PACKAGING
(SEE FIG 6 - SHEET 2)(SEE NOTE 7 & 8)
-FR: FULL REEL QTY. TAPE & REEL
(SEE FIG 6 - SHEET 2)(SEE NOTE 7 & 8)

No OF POSITIONS
-07 THRU -69
(UNSHROUDED)
-15 THRU -69
(SHROUDED)

BODY SPEC
SEE TABLE 1

PLATING SPECIFICATIONS
-L: 10µ" SELECTIVE GOLD IN CONTACT AREA, MATTE TIN ON TAIL
-F: 3µ" FLASH SELECTIVE GOLD IN CONTACT AREA, MATTE TIN ON TAIL
-H: 30µ" HEAVY GOLD IN CONTACT AREA 3µ" MIN ON TAIL
-LM: 10µ" LIGHT SELECTIVE GOLD IN CONTACT, MATTE TIN ON TAIL
-FM: 3µ" FLASH SELECTIVE GOLD IN CONTACT, MATTE TIN TAIL

PICK & PLACE PAD
-P: PICK & PLACE PAD
(SEE FIG 4, SHEET 2)
(AVAILABLE ON POSITIONS -13 THRU -69) (SEE NOTE 3)

OPTIONS
-S: END SHROUDS (SEE FIG 2)
(N/A BELOW 15 POSITIONS)
-A: ALIGNMENT PINS
(SEE FIG 3 - SHEET 2)
(MINIMUM 13 POSITIONS)

STYLE
-V: VERTICAL

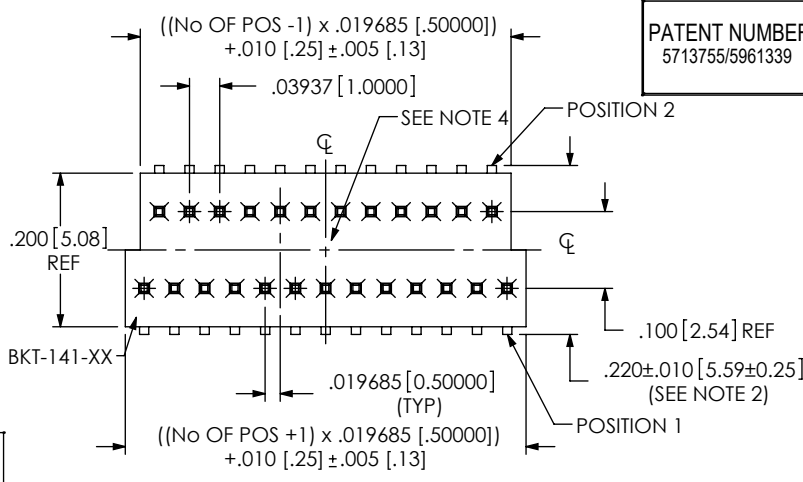

DO NOT SCALE FROM THIS PRINT

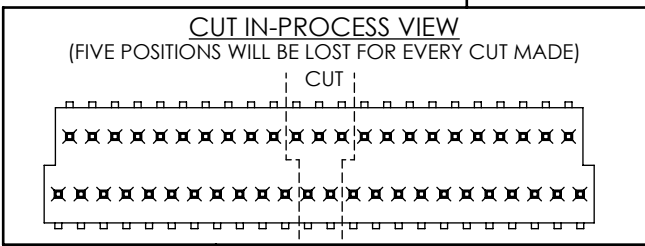
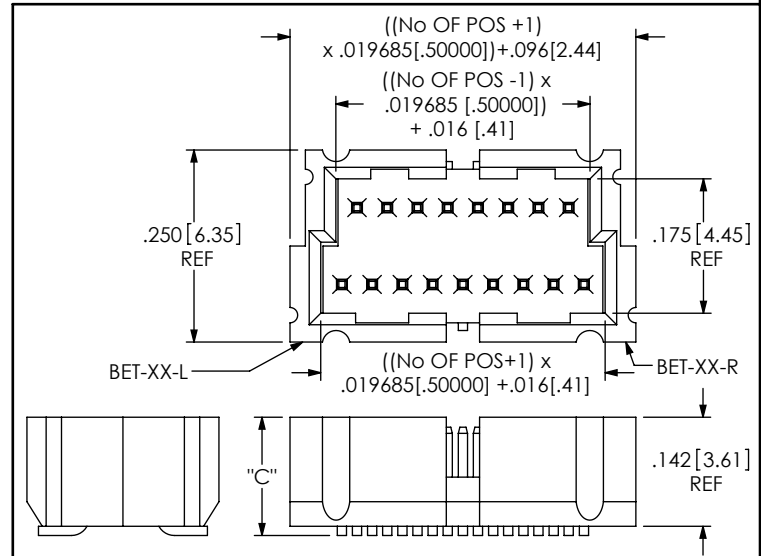
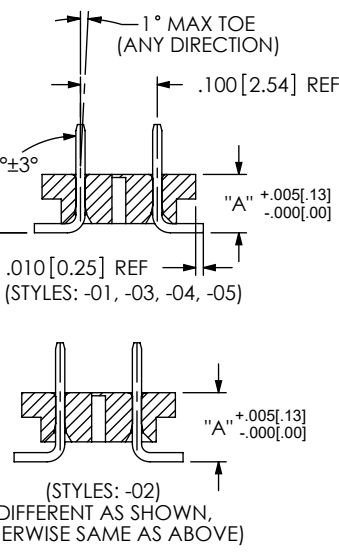
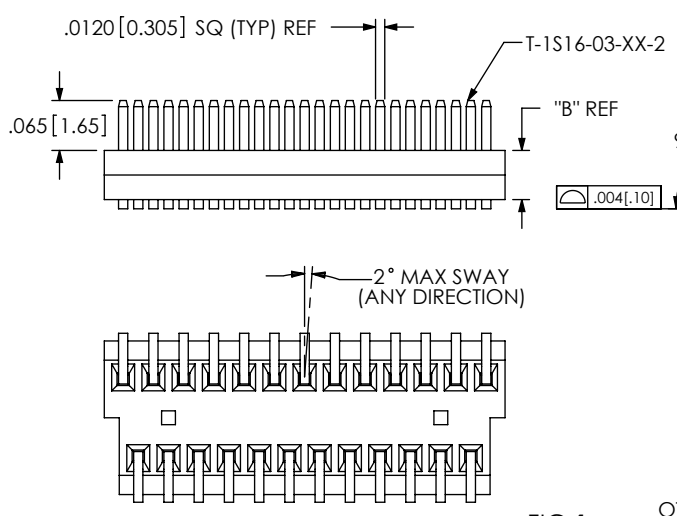

TABLE 1					
STYLE	"A"	"B" REF	"C"	BOARD SPACE MATED W / BKS	BODY USAGE
-01	.076 [1.93]	.064 [1.63]	.154 [3.91]	.163 [4.14]	BKT-141-01
-02	.090 [2.29]	.064 [1.63]	.168 [4.27]	.177 [4.50]	BKT-141-01
-03	.110 [2.79]	.098 [2.49]	.188 [4.78]	.197 [5.00]	BKT-141-03
-04	.149 [3.78]	.137 [3.48]	.227 [5.77]	.236 [5.99]	BKT-141-04
-05	.189 [4.80]	.177 [4.50]	.267 [6.78]	.276 [7.01]	BKT-141-05

- NOTES:**
- ⊕ REPRESENTS A CRITICAL DIMENSION.
 - SHEAR TAILS TO DIMENSION AS SHOWN.
 - USE LMP-01 FOR LEAD STYLES -01 & -02. USE LMP-06 FOR STYLES -03, -04 & -05. (SEE FIGURE 4).
 - CENTER TOP VOID CORING MAY OR MAY NOT BE PRESENT.
 - MIN RETENTION: 12 oz.
 - TUBES ARE STANDARD PACKAGING.
 - ORDERS WILL BE PACKAGED ACCORDING TO THE SAMTEC PACKAGING EFFICIENCY STANDARDS (SPES) FOUND ON WWW.SAMTEC.COM
 - ATTACH LABEL TO EACH REEL

UNLESS OTHERWISE SPECIFIED, DIMENSIONS ARE IN INCHES. TOLERANCES ARE:
DECIMALS ANGLES
.XX: ±.01 [.3] 3°
.XXX: ±.005 [.13]
.XXXX: ±.0020 [.051]

PROPRIETARY NOTE
THIS DOCUMENT CONTAINS INFORMATION CONFIDENTIAL AND PROPRIETARY TO SAMTEC, INC. AND SHALL NOT BE REPRODUCED OR TRANSFERRED TO OTHER DOCUMENTS OR DISCLOSED TO OTHERS OR USED FOR ANY PURPOSE OTHER THAN THAT WHICH IT WAS OBTAINED WITHOUT THE EXPRESSED WRITTEN CONSENT OF SAMTEC, INC.

samtec
520 PARK EAST BLVD, NEW ALBANY, IN 47150
PHONE: 812-944-6733 FAX: 812-948-5047
e-Mail: info@SAMTEC.com code 55322

DO NOT SCALE DRAWING SHEET SCALE: 4:1
MATERIAL:
INSULATOR: LCP, UL 94 VO, COLOR BLACK.
TERMINAL: PHOS BRONZE, SPRING TEMPER
F:\DWG\MISC\MKTG\BKT-1XX-XX-XX-V-XX-X-XX-MKT.SLDDRW

DESCRIPTION:
1MM C.L. STAGGERED SURFACE MOUNT TERMINAL STRIP ASSEMBLY
DWG. NO.
BKT-1XX-XX-XX-V-XX-X-XX
BY: BRATCHER 03/28/95 **SHEET 1 OF 2**

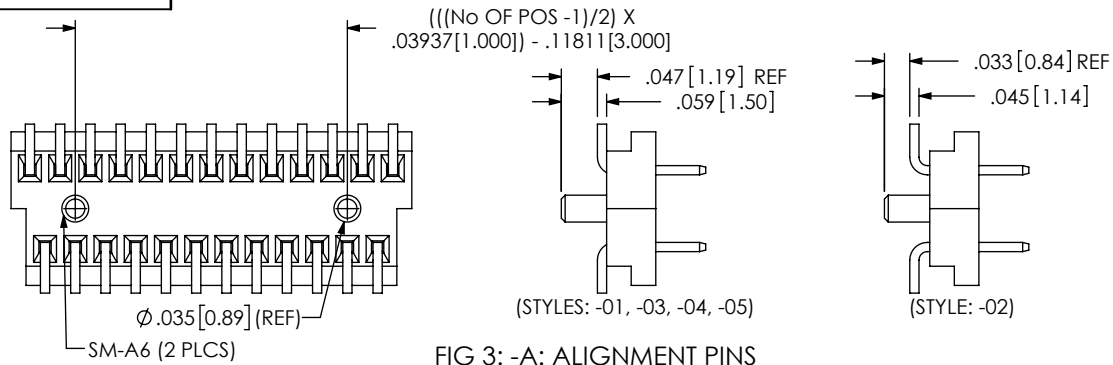
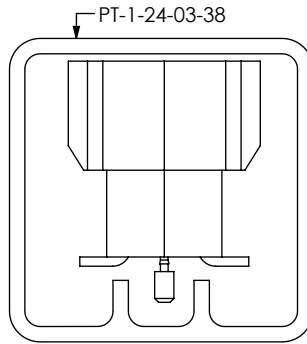
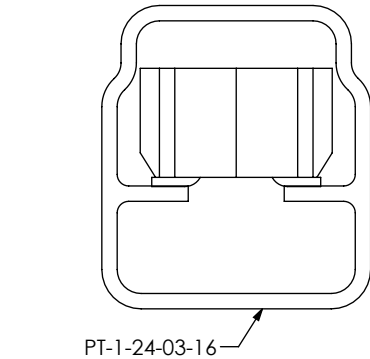
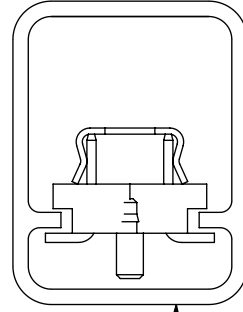
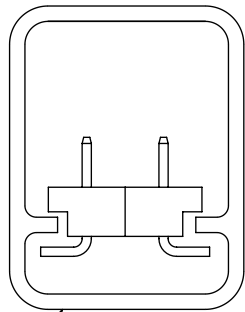
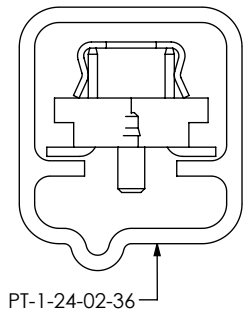

FIG 3: -A: ALIGNMENT PINS
DIFFERENT AS SHOWN,
OTHERWISE SAME AS FIG 1



TUBE VIEWS

PACKAGING TABLE			
STYLE	OPTIONS	PACKAGING TUBE	PLUGS
-01, -02	-A, -A-P, -P	PT-1-24-02-36	TP-24-02
-01, -02	NONE	PT-BKT001	TP-03
-01, -02	-S, -S-A, -S-P, -S-A-P	PT-1-24-03-16	TP-03
-03	NONE, -A, -S, -S-A, -S-P, -S-A-P,	PT-BKT001	TP-03
-04	NONE, -A, -A-P, -S, -S-A, -S-P, -S-A-P, -P	PT-BKT001	TP-03
-05	NONE, -A, -P, -A-P	PT-BKT001	TP-03
-05	-S, -S-A, -S-P, -S-A-P	PT-1-24-03-38	TP-03

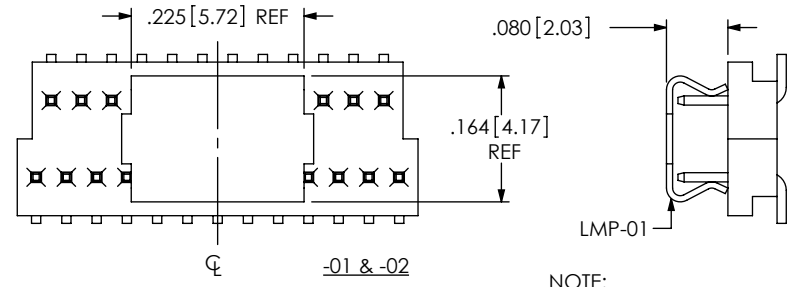
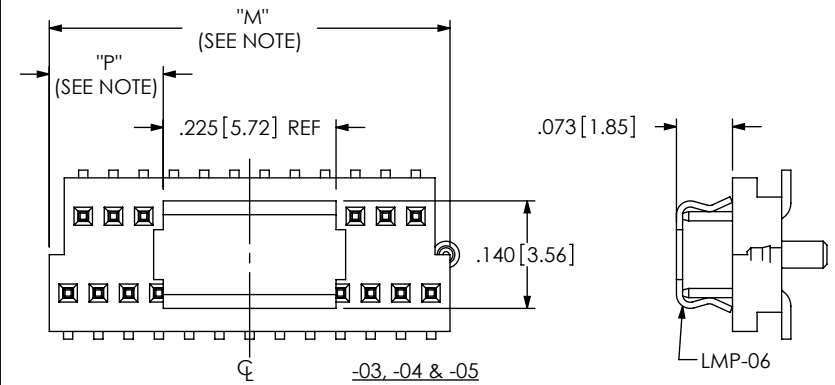

FIG 4: -P: -PICK & PLACE PAD
DIFFERENT AS SHOWN,
OTHERWISE SAME AS FIG 1

NOTE:
"M" = USED MEASURED
DIMENSION (REF)
"P" = (("M" - .225[5.72]) / 2)
±.020[.51]

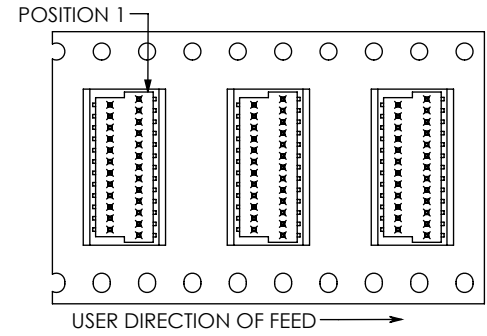

FIG 5: -TR: -TAPE & REEL

PROPRIETARY NOTE

THIS DOCUMENT CONTAINS INFORMATION
CONFIDENTIAL AND PROPRIETARY TO
SAMTEC, INC. AND SHALL NOT BE REPRODUCED
OR TRANSFERRED TO OTHER DOCUMENTS OR
DISCLOSED TO OTHERS OR USED FOR ANY
PURPOSE OTHER THAN THAT WHICH IT WAS
OBTAINED WITHOUT THE EXPRESSED WRITTEN
CONSENT OF SAMTEC, INC.

DO NOT SCALE DRAWING

SHEET SCALE: 4:1



520 PARK EAST BLVD, NEW ALBANY, IN 47150
PHONE: 812-944-6733 FAX: 812-948-5047
e-Mail info@SAMTEC.com code 55322

DESCRIPTION:
1MM C.L. STAGGERED SURFACE MOUNT TERMINAL STRIP ASSEMBLY

DWG. NO.
BKT-1XX-XX-XX-V-XX-X-XX

BY: BRATCHER 03/28/95 SHEET 2 OF 2