

DO NOT SCALE FROM THIS PRINT

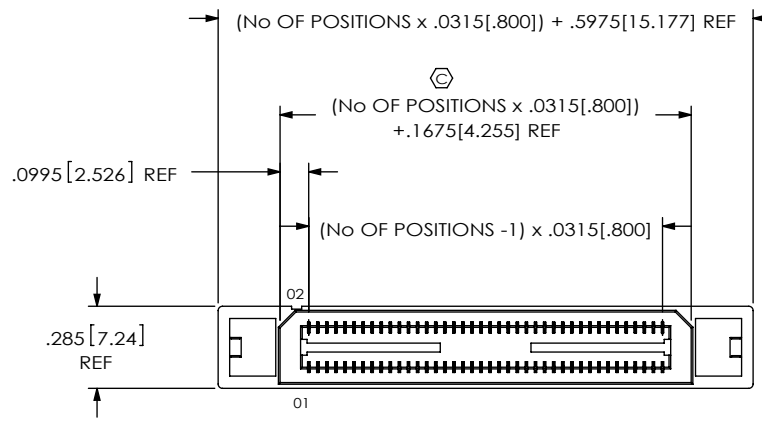

BSE-XXX-01-X-D-EMX-XX

No OF POSITIONS (PER ROW)
-020, -040, -060
-080, -100, -120

LEAD STYLE
-01

PLATING SPECIFICATION

OPTION
-GP: GUIDE POST (60 POS MAX)
(USE BSE-XXX-01-EM2-GP)
[SEE SHEET 2, FIG 2 -
AVAILABLE ONLY ON -EM2]

EDGE MOUNT THICKNESS
-EM2: .064[1.63] ±.004 PCB
(USE BSE-XXX-01-D-EM2 & C-162-01-X)
-EM3: (USE BSE-XXX-01-D-EM3
& C-162-02-X)

SEE NOTE 6

ROW SPECIFICATION
-D: DOUBLE (USE BSE-XXX-01-D-EMX)

FIG 1
BSE-040-01-X-D-EM2 SHOWN

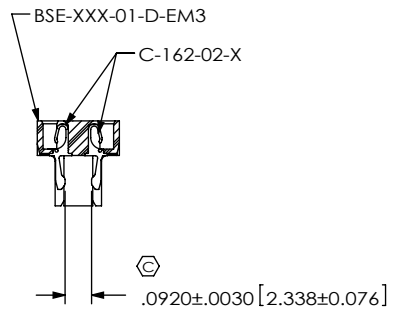
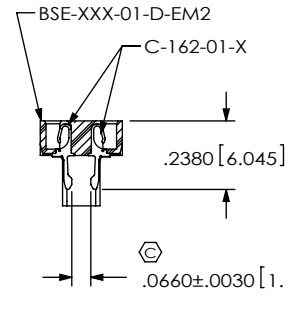
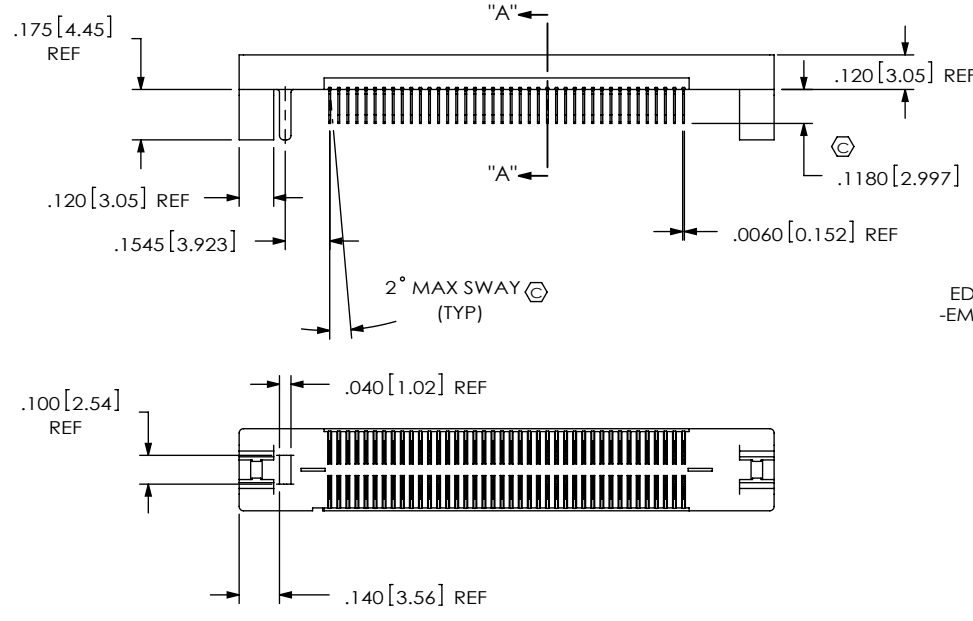

SECTION "A-A"
EDGE MOUNT THICKNESS
-EM2: .064[1.63] ±.004 PCB

SECTION "A-A"
EDGE MOUNT THICKNESS
-EM3:
SEE NOTE 6

(DIFFERENT AS SHOWN, OTHERWISE SAME AS -EM2 PCB THICKNESS)

NOTES:

1. Ⓢ REPRESENTS A CRITICAL DIMENSION.
2. CONTACT RETENTION: 4 OZ MIN.
3. DELETED.
4. PARTS ARE "MOLD TO POSITION".
5. MAX VARIANCE OF .002.
6. -EM3 IS NOT A STANDARD OFFERING; AVAILABLE AS AN ASP ONLY. PLEASE CONTACT SAMTEC INTERCONNECT PROCESSING GROUP WITH ORDER INQUIRIES.
7. NOTE DELETED.

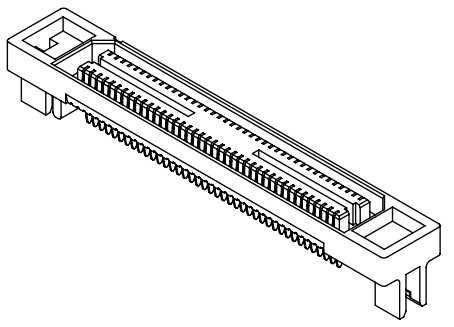

<p>UNLESS OTHERWISE SPECIFIED, DIMENSIONS ARE IN INCHES. TOLERANCES ARE:</p> <p>DECIMALS ANGLES</p> <p>.XX: ±.01[.3] 2°</p> <p>.XXX: ±.005[.13]</p> <p>.XXXX: ±.0020[.051]</p>	<p>PROPRIETARY NOTE</p> <p>THIS DOCUMENT CONTAINS INFORMATION CONFIDENTIAL AND PROPRIETARY TO SAMTEC, INC. AND SHALL NOT BE REPRODUCED OR TRANSFERRED TO OTHER DOCUMENTS OR DISCLOSED TO OTHERS OR USED FOR ANY PURPOSE OTHER THAN THAT WHICH IT WAS OBTAINED WITHOUT THE EXPRESSED WRITTEN CONSENT OF SAMTEC, INC.</p>		
		<p>520 PARK EAST BLVD, NEW ALBANY, IN 47150 PHONE: 812-944-6733 FAX: 812-948-5047 e-Mail: info@SAMTEC.com code: 55322</p>	
<p>MATERIAL: DO NOT SCALE DRAWING SHEET SCALE: 1.5:1</p> <p>INSULATOR: VECTRA E130i, COLOR: BLACK</p> <p>CONTACT: PHOS BRONZE, 510 SPRING TEMPER</p> <p>THICKNESS: .0060</p>	<p>DESCRIPTION: .8mm EDGE MOUNT MI SOCKET ASSEMBLY</p>	<p>DWG. NO. BSE-XXX-01-X-D-EMX-XX</p>	<p>BY: DEAN P 5/25/2000 SHEET 1 OF 2</p>
<p>F:\DWG\MISC\MKTG\BSE-XXX-01-X-D-EMX-XX-MKT.SLDDRW</p>			

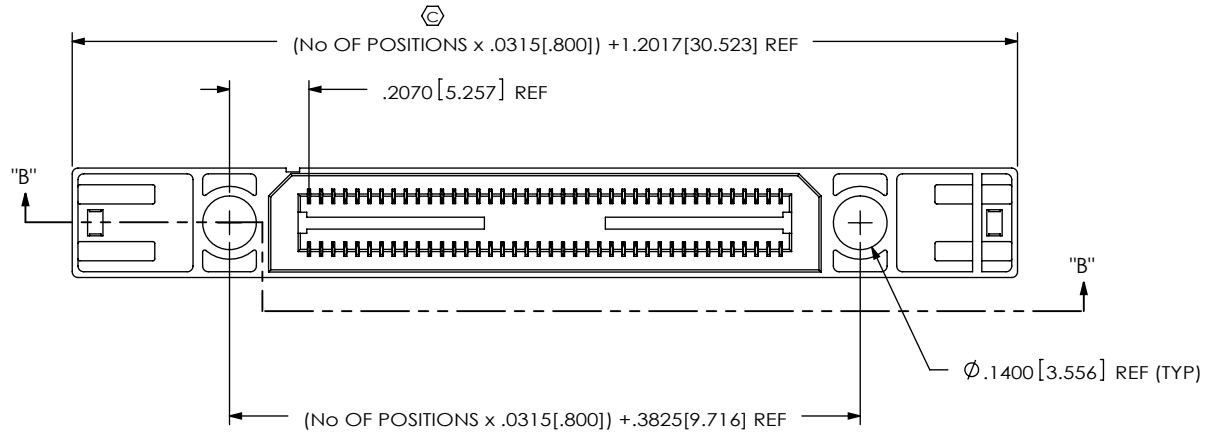
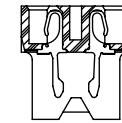
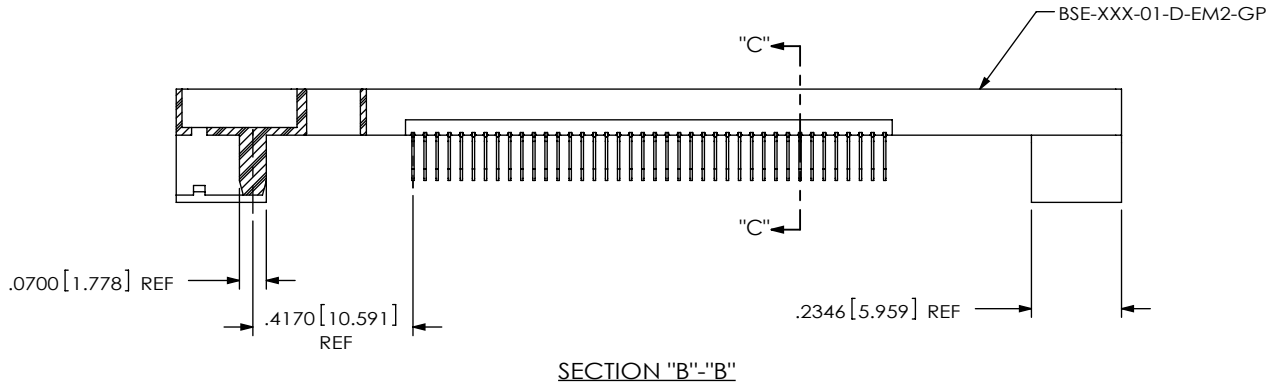
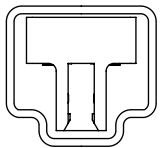

FIG 2
 -GP: GUIDE POST
 BSE-040-01-X-D-EM2-GP SHOWN
 (60 POSITION MAX)
 [DIFFERENT AS SHOWN, OTHERWISE
 SAME AS FIG 1]



SECTION "C"-"C"

PACKAGING VIEW



-EMX

TUBE: PT-1-24-02-38
 PLUG: TP-03

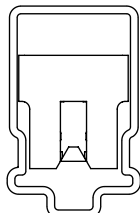

-EMX-GP

TUBE: PT-1-24-01-86
 PLUG: TP-07

PROPRIETARY NOTE

THIS DOCUMENT CONTAINS INFORMATION
 CONFIDENTIAL AND PROPRIETARY TO
 SAMTEC, INC. AND SHALL NOT BE REPRODUCED
 OR TRANSFERRED TO OTHER DOCUMENTS OR
 DISCLOSED TO OTHERS OR USED FOR ANY
 PURPOSE OTHER THAN THAT WHICH IT WAS
 OBTAINED WITHOUT THE EXPRESSED WRITTEN
 CONSENT OF SAMTEC, INC.

DO NOT SCALE DRAWING

SHEET SCALE: 2:1



520 PARK EAST BLVD, NEW ALBANY, IN 47150
 PHONE: 812-944-6733 FAX: 812-948-5047
 e-Mail: info@SAMTEC.com code: 55322

DESCRIPTION:
 .8mm EDGE MOUNT MI SOCKET ASSEMBLY

DWG. NO.
BSE-XXX-01-X-D-EMX-XX

BY: DEAN P 5/25/2000 SHEET 2 OF 2