

DO NOT SCALE FROM THIS PRINT

TABLE 1					MATED HEIGHT WITH BSS
STYLE	"A"	"B" REF	BODY	TERMINAL	
-01	.1680[4.267]	.1600[4.064] REF	BTS-XXX-01-D-XX	T-1S56-01-X	.197[5.00] REF
* -02	.2861[7.267]	.2781[7.064] REF	BTS-XXX-02-D-XX	T-1S56-22-X	.315[8.00] REF

* NOT ENGINEERING APPROVED

BTS-XXX-XX-X-D-XX-X-XX

No OF POSITIONS
 -025, -050, -075 (SEE NOTE 11),
 -100, -125, -150
 (PER ROW)

PACKAGING
 BLANK: TRAY(SEE NOTE 14 & 15)
 -TR: TAPE & REEL (100 POS MAX)
 (SEE NOTE 15 & 16)
 -FR: FULL REEL QTY TAPE & REEL
 (100 POR MAX)(SEE NOTE 15 & 16)

PICK AND PLACE OPTION
 BLANK: NO PICK AND PLACE PAD
 -K: POLYIMIDE FILM PAD
 (USE K-DOT-.276-.375-.005,
 SEE FIG 2)

OPTION
 -A: ALIGNMENT PINS
 (SEE FIGS 1 & 4)
 -LC: LOCKING CLIPS
 (USE LC-08-T-01)

ROW SPECIFICATION
 -D: DOUBLE (USE BTS-XXX-XX-D &
 BTSH-XXX-XX-D)

* NOT ENGINEERING APPROVED
 (SEE NOTE 11)

BODY STYLE
 -01: .1680 [4.267]
 * -02: .2861 [7.268]
 * -03: .4042 [10.267]
 * -04: .6000 [15.240]

PLATING SPECIFICATION
 -F: FLASH SELECTIVE GOLD,
 MATTE TIN TAILS
 (USE T-1SXX-XX-F)(SEE NOTE 9)
 -L: LIGHT SELECTIVE GOLD,
 MATTE TIN TAILS
 (USE T-1SXX-XX-L)
 -H: HEAVY GOLD
 (USE T-1SXX-XX-H)

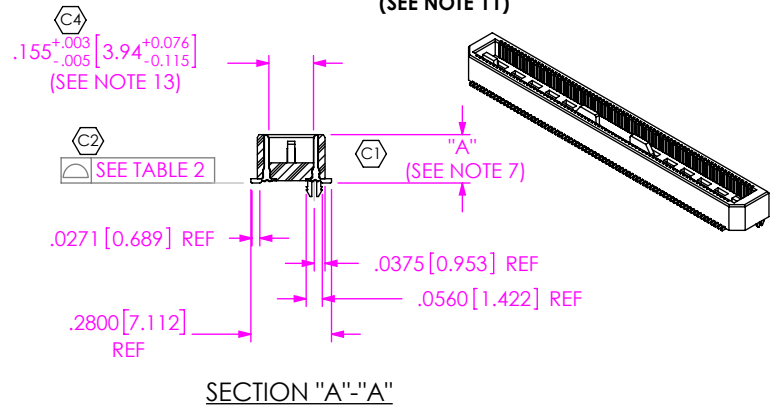
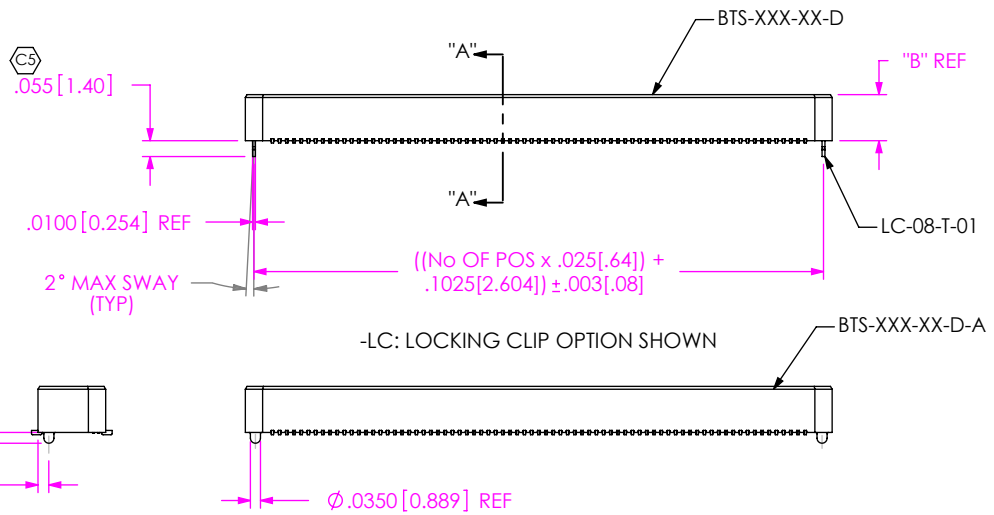
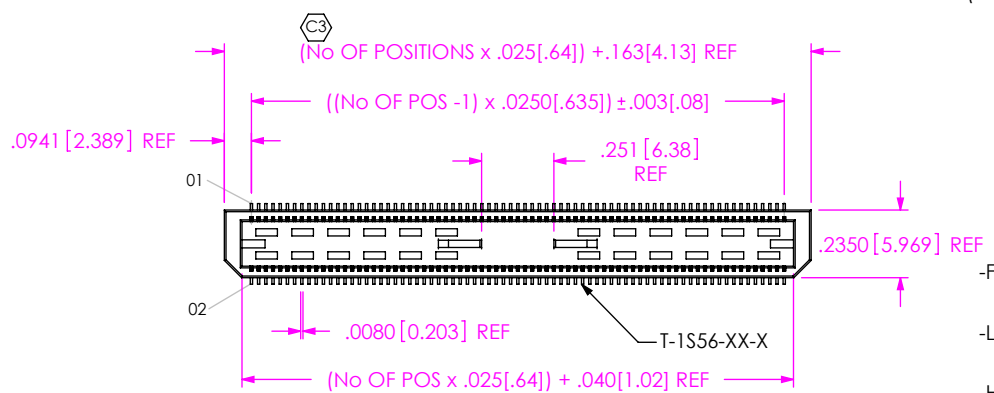

- NOTES:
1. © REPRESENTS A CRITICAL DIMENSION.
 2. NOTE DELETED.
 3. MAXIMUM BURR ALLOWANCE: .0015[.038].
 4. MAXIMUM CUT FLASH: .010[.25].
 5. MINIMUM PUSHOUT FORCE: 6 OZ.
 6. NOTE DELETED.
 7. MAXIMUM VARIANCE: .002[.05].
 8. LEAD STYLES -03 & -04: TOP BODY (BTS) CANNOT HAVE -A OPTION.
 9. -L PLATING CAN BE SUBSTITUTED FOR -F PLATING.
 10. NOTE DELETED.
 11. RELEASE FOR SALE THE -02 LEAD STYLE, IN -075 POSITION ONLY, FOR SPECIFIC CUSTOMER NEED.
 12. NOTE DELETED.
 13. PIN CAN EXTEND PAST WALL .003 [.08] MAXIMUM.
 14. TRAYS ARE STANDARD PACKAGING.
 15. ORDERS WILL BE PACKAGED ACCORDING TO THE SAMTEC PACKAGING EFFICIENCY STANDARDS (SPES) FOUND ON WWW.SAMTEC.COM
 16. ATTACH LABEL -4X2 TO EACH REEL.

FIG 1

TABLE 2	
No OF POSITIONS	COPLANARITY
-025 THRU -075	.004[.10]
-100 THRU -150	.006[.15]

UNLESS OTHERWISE SPECIFIED, DIMENSIONS ARE IN INCHES. TOLERANCES ARE: DECIMALS ANGLES .XX: ±.01 [.3] .XXX: ±.005 [.13] .XXXX: ±.0020 [.051]	PROPRIETARY NOTE THIS DOCUMENT CONTAINS INFORMATION CONFIDENTIAL AND PROPRIETARY TO SAMTEC, INC. AND SHALL NOT BE REPRODUCED OR TRANSFERRED TO OTHER DOCUMENTS OR DISCLOSED TO OTHERS OR USED FOR ANY PURPOSE OTHER THAN THAT WHICH IT WAS OBTAINED WITHOUT THE EXPRESSED WRITTEN CONSENT OF SAMTEC, INC.	 520 PARK EAST BLVD, NEW ALBANY, IN 47150 PHONE: 812-944-6733 FAX: 812-948-5047 e-Mail: info@SAMTEC.com code: 55322

FIG 2
 -K: POLYIMIDE FILM PAD
 (USE K-DOT-.276-.375-.005)



NOTE: "R" = (No OF POSITIONS x .0250[.635] + .1625[4.128])
 "S" = (("R" - .276[7.01]) / 2) ± .020[.51]

TABLE 3	
STYLE	"C"
-01	.173[4.39]
* -02	.291[7.39]
* -03	.409[10.39]
* -04	.605[15.37]

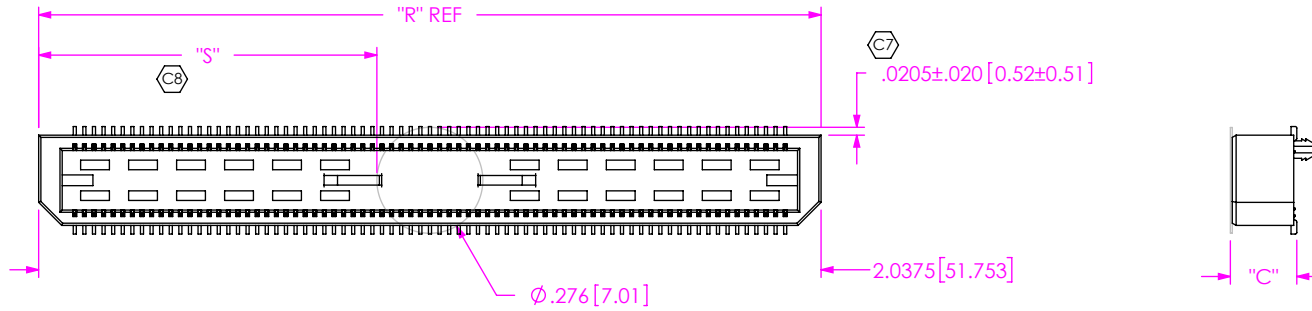
* NOT ENGINEERING APPROVED
 (SEE NOTE 11)

c:\enterprisevault\DWG\MISC\MKTG\BTS-XXX-XX-X-D-XX-MKT.SLDDRW

PROPRIETARY NOTE
 THIS DOCUMENT CONTAINS INFORMATION
 CONFIDENTIAL AND PROPRIETARY TO
 SAMTEC, INC. AND SHALL NOT BE REPRODUCED
 OR TRANSFERRED TO OTHER DOCUMENTS OR
 DISCLOSED TO OTHERS OR USED FOR ANY
 PURPOSE OTHER THAN THAT WHICH IT WAS
 OBTAINED WITHOUT THE EXPRESSED WRITTEN
 CONSENT OF SAMTEC, INC.

DO NOT SCALE DRAWING

SHEET SCALE: 2:1



520 PARK EAST BLVD, NEW ALBANY, IN 47150
 PHONE: 812-944-6733 FAX: 812-948-5047
 e-Mail: info@SAMTEC.com code: 55322

DESCRIPTION: .635mm DOUBLE ROW SOCKET ASSEMBLY

DWG. NO. **BTS-XXX-XX-X-D-XX**

BY: DEAN P 06/24/1999 SHEET 2 OF 3

FIG 3
 BTS-075-03-X-D-LC SHOWN
 (SAME AS FIG 1, UNLESS OTHERWISE STATED)

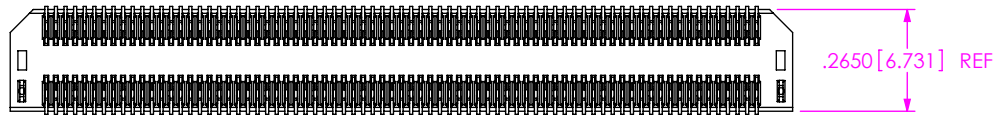
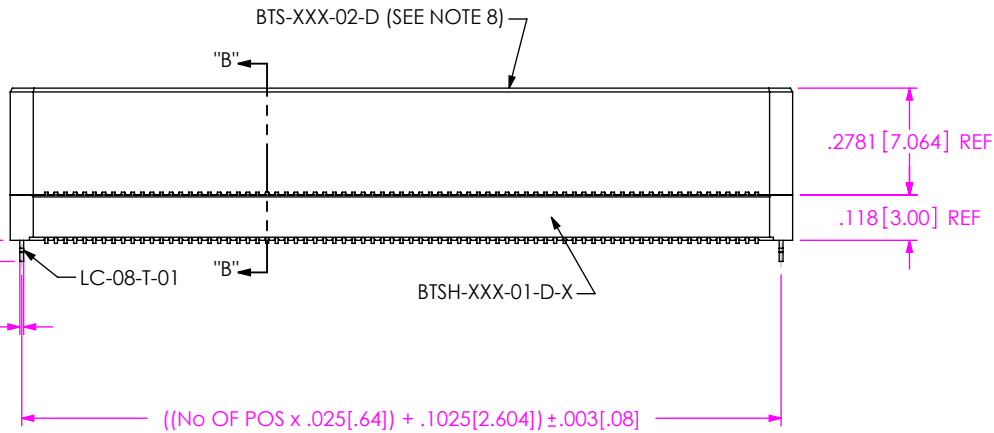
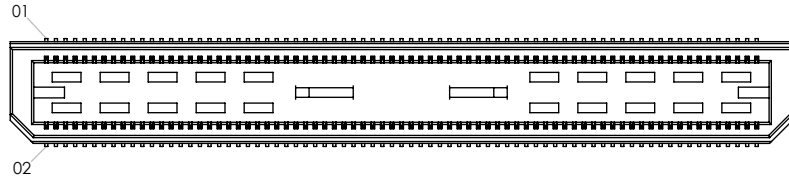
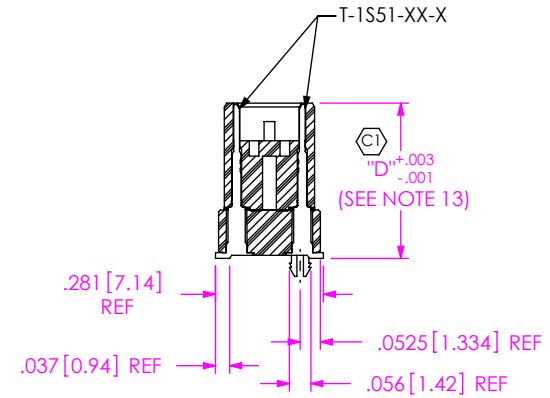

TABLE 4				MATED HEIGHT WITH BSS-01
STYLE	"D"	TERMINAL	BOTTOM SPACER BODY	
* -03	.4042 [10.267]	T-1S51-03-X	BTSH-XXX-01-D-X	.433 [11.00] REF
* -04	.6000 [15.240]	T-1S51-04-X	BTSH-XXX-01-D-X	.630 [16.00] REF

* NOT ENGINEERING APPROVED



SECTION "B"- "B"

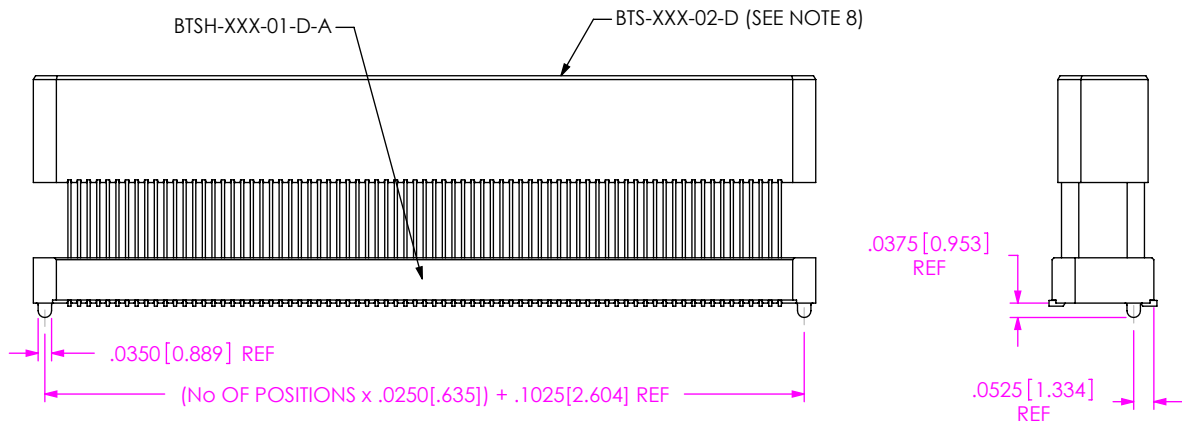

FIG 4

-A: ALIGNMENT PIN OPTION FOR -03 & -04 LEAD STYLES
 BTS-075-04-X-D-A SHOWN
 (SAME AS FIG 3, UNLESS OTHERWISE STATED)

c:\enterprise\dwg\MISC\MKTG\BTS-XXX-XX-X-D-XX-MKT.SLDDRW

PROPRIETARY NOTE

THIS DOCUMENT CONTAINS INFORMATION CONFIDENTIAL AND PROPRIETARY TO SAMTEC, INC. AND SHALL NOT BE REPRODUCED OR TRANSFERRED TO OTHER DOCUMENTS OR DISCLOSED TO OTHERS OR USED FOR ANY PURPOSE OTHER THAN THAT WHICH IT WAS OBTAINED WITHOUT THE EXPRESSED WRITTEN CONSENT OF SAMTEC, INC.

DO NOT SCALE DRAWING

SHEET SCALE: 2:1



520 PARK EAST BLVD, NEW ALBANY, IN 47150
 PHONE: 812-944-6733 FAX: 812-948-5047
 e-Mail: info@SAMTEC.com code: 55322

DESCRIPTION:
 .635mm DOUBLE ROW SOCKET ASSEMBLY

DWG. NO. **BTS-XXX-XX-X-D-XX**

BY: DEAN P 06/24/1999 SHEET 3 OF 3