

# REVISION AF

## NOTES:

1.  $\text{\textcircled{C}}$  REPRESENTS A CRITICAL DIMENSION.
2. ALL DIMENSION TO BE SYMMETRICAL ABOUT CENTERLINE WITHIN  $\pm .002[.05]$  UNLESS OTHERWISE STATED.
3. POSITIONS -05 THRU -50 ARE TO BE PACKAGED IN TUBES.
4. MIN CONTACT RETENTION FORCE: 1LB.
5. TAILS TO ARE TO BE SHEARED. MAX BURR, ORIENTED AWAY FROM CUSTOMER'S P.C.B. ONLY, TO BE  $.0045[.114]$ .
6. MAX CUT FLASH:  $.015$  IN NON-CRITICAL AREAS; NO CUT FLASH TO BE PRESENT IN CRITICAL AREAS AS SHOWN
7. MOLD STEEL CAPABLE OF -02 & -03 POSITION (-A OPTION), BUT NOT ENG'G APPROVED.
8. FIRST AND LAST PIN OF EACH ROW TO BE FLUSH TO  $.003[0.08]$  BELOW BODY.
9. NOTE DELETED.
10. NOTE DELETED.
11. TUBES ARE STANDARD PACKAGING.
12. ORDERS WILL BE PACKAGED ACCORDING TO THE SAMTEC PACKAGING EFFICIENCY STANDARDS (SPES) FOUND ON WWW.SAMTEC.COM
13. ATTACH LABEL TO EACH REEL.

DO NOT SCALE FROM THIS PRINT

## CLP-1XX-XX-X-DH-X-XX

No. OF POSITIONS PER ROW  
-02 THRU -50

LEAD STYLE  
-02: SURFACE MOUNT

### PLATING

- F:  $3\mu$ " FLASH SELECTIVE GOLD IN CONTACT AREA, MATTE TIN ON TAIL
- L:  $10\mu$ " LIGHT SELECTIVE GOLD IN CONTACT AREA, MATTE TIN ON TAIL
- FM:  $3\mu$ " FLASH SELECTIVE GOLD IN CONTACT AREA, MATTE TIN ON TAIL
- LM:  $10\mu$ " LIGHT SELECTIVE GOLD IN CONTACT AREA, MATTE TIN ON TAIL

### PACKAGING

- BLANK: TUBES (SEE NOTE 11)
- TR: TAPE AND REEL PACKAGING (SEE NOTE 12 & 13)
- FR: FULL REEL QTY. TAPE & REEL (SEE NOTE 12 & 13)

### OPTION

- BLANK: NO ALIGNMENT PINS
- A: ALIGNMENT PIN (USE CLP-XX-DH-A BODIES MUST BE MODLED TO POSITION) (AVAILABLE ON POSITIONS -04 THRU -50) (SEE NOTE 7)

### BODY SPECIFICATION

- DH: DOUBLE HORIZONTAL

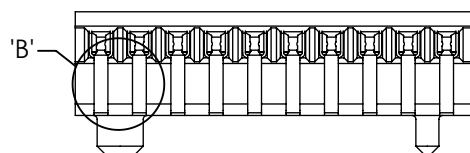
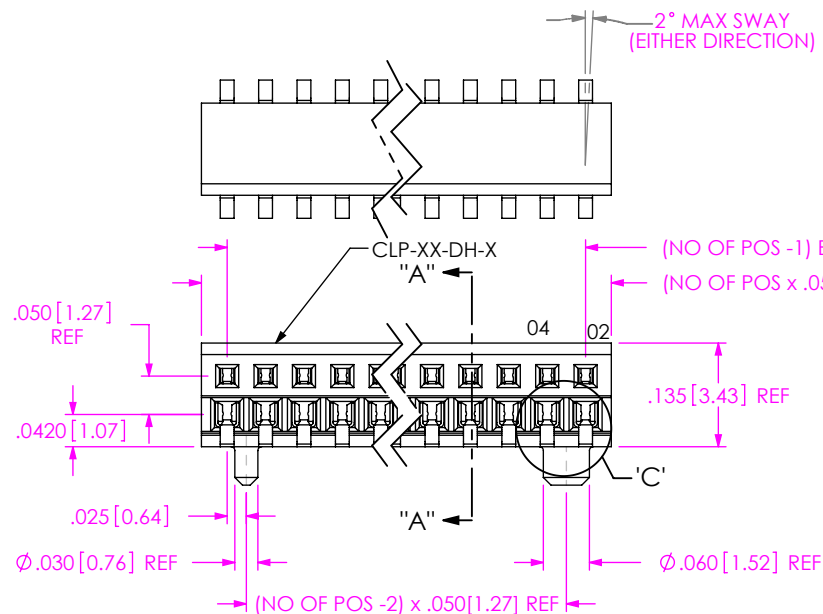

BACK VIEW

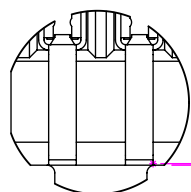

DETAIL 'B'  
SCALE 8:1

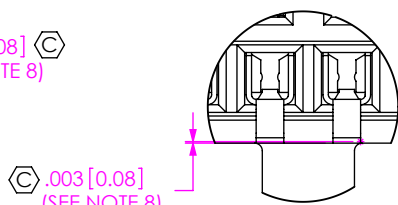

DETAIL 'C'  
SCALE 8:1

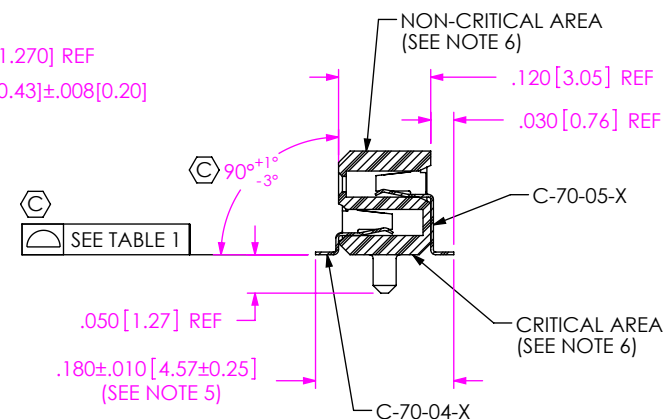

SECTION "A"-A"

TABLE 1

POSITION	COPLANARITY
-02 THRU -40	.004 [0.10]
-41 THRU -50	.006 [0.15]

UNLESS OTHERWISE SPECIFIED, DIMENSIONS ARE IN INCHES.

TOLERANCES ARE:

DECIMALS ANGLES  
 .XX:  $\pm .01 [0.3]$  2°  
 .XXX:  $\pm .005 [0.13]$   
 .XXXX:  $\pm .0020 [0.051]$

### PROPRIETARY NOTE

THIS DOCUMENT CONTAINS CONFIDENTIAL AND PROPRIETARY INFORMATION AND ALL DESIGN, MANUFACTURING, REPRODUCTION, USE, PATENT RIGHTS AND SALES RIGHTS ARE EXPRESSLY RESERVED BY SAMTEC, INC. THIS DOCUMENT SHALL NOT BE DISCLOSED, IN WHOLE OR PART, TO ANY UNAUTHORIZED PERSON OR ENTITY NOR REPRODUCED, TRANSFERRED OR INCORPORATED IN ANY OTHER PROJECT IN ANY MANNER WITHOUT THE EXPRESS WRITTEN CONSENT OF SAMTEC, INC.

MATERIAL: DO NOT SCALE DRAWING SHEET SCALE: 4:1  
 INSULATOR: LCP, UL 94 VO, COLOR: BLACK  
 CONTACT: PHOS BRONZE

**samtec**

520 PARK EAST BLVD, NEW ALBANY, IN 47150  
 PHONE: 812-944-6733 FAX: 812-948-5047  
 e-Mail: info@SAMTEC.com code 53322

DESCRIPTION:  
 LOW PROFILE .050 X .050 DOUBLE ROW ASM  
 DWG. NO. CLP-1XX-XX-X-DH-X-XX

BY: PURVIS 11-29-1995 SHEET 1 OF 2

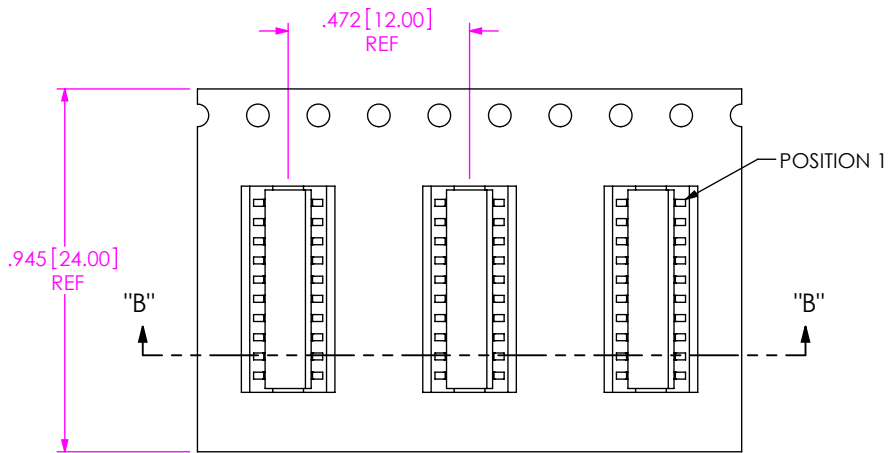

← USER DIRECTION OF UNREELING

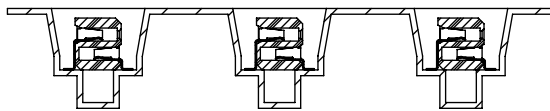

-TR: TAPE & REEL VIEW  
(SCALE 2:1)

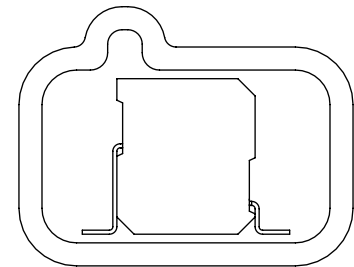

-DH NO OPTION  
PT-1-24-02-37  
(TUBE USES (2) TP-12)

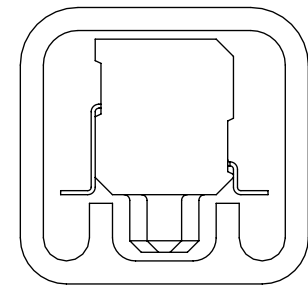

WITH -A OPTION  
PT-1-24-01-62  
(TUBE USES (2) TP-12)

PACKAGING TUBE VIEW  
(SCALE 6:1)

**PROPRIETARY NOTE**  
THIS DOCUMENT CONTAINS CONFIDENTIAL AND PROPRIETARY INFORMATION AND ALL DESIGN, MANUFACTURING, REPRODUCTION, USE, PATENT RIGHTS AND SALES RIGHTS ARE EXPRESSLY RESERVED BY SAMTEC, INC. THIS DOCUMENT SHALL NOT BE DISCLOSED, IN WHOLE OR PART, TO ANY UNAUTHORIZED PERSON OR ENTITY NOR REPRODUCED, TRANSFERRED OR INCORPORATED IN ANY OTHER PROJECT IN ANY MANNER WITHOUT THE EXPRESS WRITTEN CONSENT OF SAMTEC, INC.

**samtec**  
520 PARK EAST BLVD, NEW ALBANY, IN 47150  
PHONE: 812-944-6733 FAX: 812-948-5047  
e-Mail info@SAMTEC.com code 55322

SHEET SCALE: 4:1

DESCRIPTION:  
LOW PROFILE .050 X .050 DOUBLE ROW ASM

DWG. NO. **CLP-1XX-XX-X-DH-X-XX**

BY: PURVIS 11-29-1995 SHEET 2 OF 2