

DO NOT
SCALE FROM
THIS PRINT

**DESIGNED AND DIMENSIONED IN MILLIMETERS[INCHES]
ALL DIMENSIONS REFERENCE**

EGBF-RA-20
ORIENTATION -RA: RIGHT ANGLE CARD SPACING -20mm

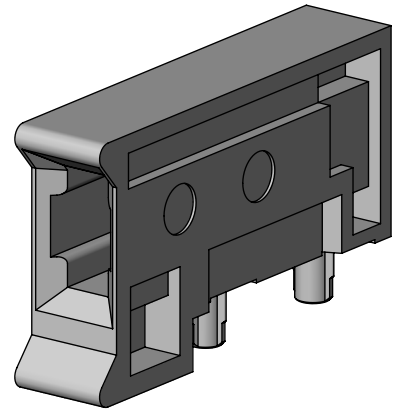
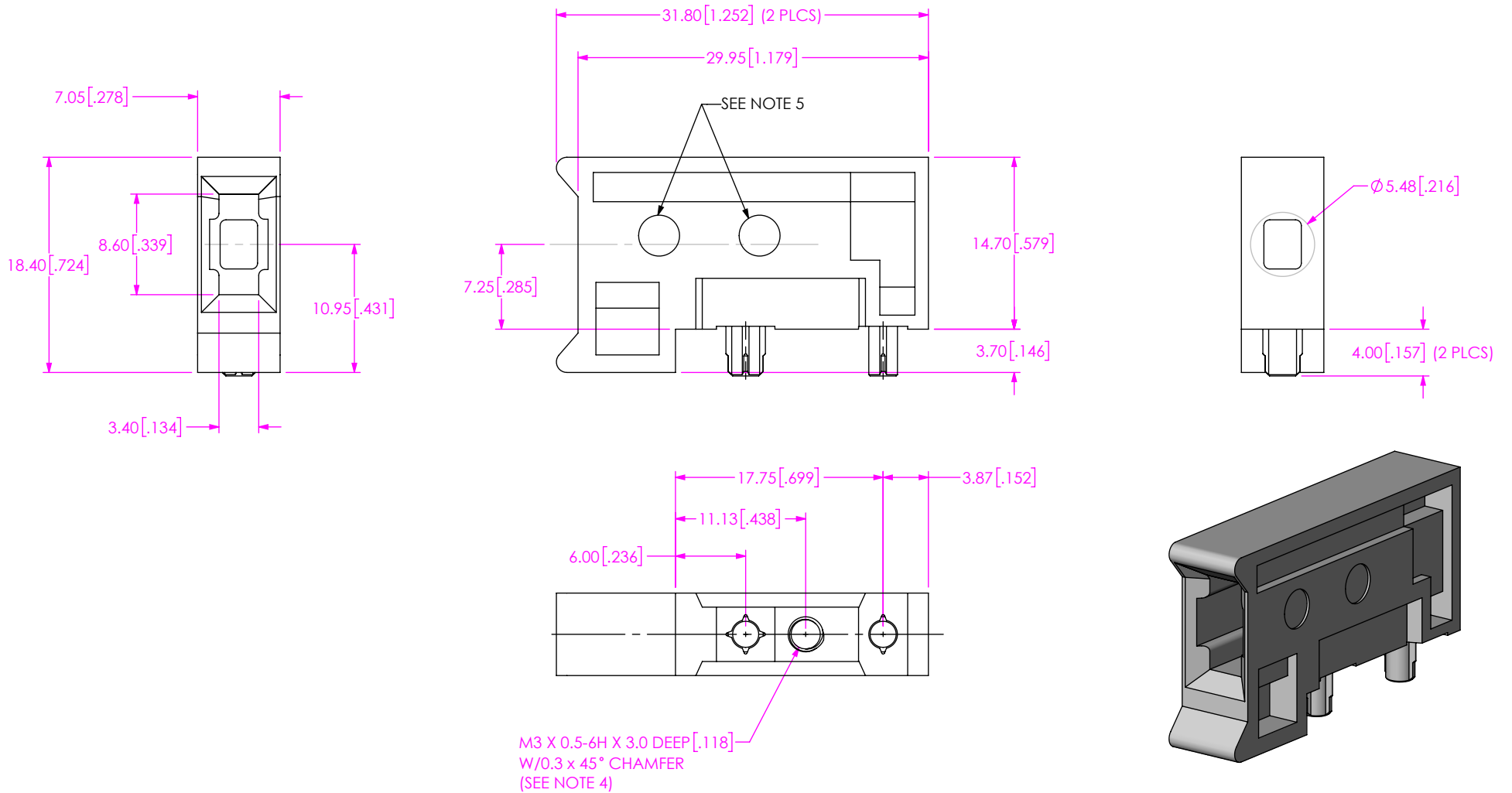

NOTES:

1. NOTE DELETED.
2. STANDARD PACKAGING: USE ASBBLT6X8.5 BAG, 100 PCS MAXIMUM.
3. SEE EGBF-RA-XX-FOOTPRINT DRAWING FOR RECOMMENDED PCB LAYOUT AND INFORMATION REGARDING PCB LAYOUT OF GUIDE MODULES RELATIVE TO SIGNAL MODULES.
4. SCREW NOT SUPPLIED, MAX SCREW LENGTH = 3.0 MM PLUS PCB THICKNESS.
5. CODE MARKING Ø3.5 X 0.25 (TYP) IN APPROXIMATE AREA SHOWN. SAME FEATURE ALLOWED ON OPPOSITE SIDE FOR BATCH MARKING.

<p>PROPRIETARY NOTE THIS DOCUMENT CONTAINS CONFIDENTIAL AND PROPRIETARY INFORMATION AND ALL DESIGN, MANUFACTURING, REPRODUCTION, USE, PATENT RIGHTS AND SALES RIGHTS ARE EXPRESSLY RESERVED BY SAMTEC, INC. THIS DOCUMENT SHALL NOT BE DISCLOSED, IN WHOLE OR PART, TO ANY UNAUTHORIZED PERSON OR ENTITY NOR REPRODUCED, TRANSFERRED OR INCORPORATED IN ANY OTHER PROJECT IN ANY MANNER WITHOUT THE EXPRESS WRITTEN CONSENT OF SAMTEC, INC.</p>		<p>samtec 520 PARK EAST BLVD, NEW ALBANY, IN 47150 PHONE: 812-944-6733 FAX: 812-948-5047 e-Mail info@SAMTEC.com code 55322</p>	
<p>DO NOT SCALE DRAWING SHEET SCALE: 2:1</p>		<p>DESCRIPTION: EXAMAX™ RIGHT ANGLE GUIDE RECEPTACLE</p>	
<p>MATERIAL: ZINC ALLOY</p>		<p>DWG. NO. EGBF-RA-20</p>	
<p>FINISH: ZINC YELLOW CHROMATE</p>		<p>BY: KNOWLDEN 9/9/2015 SHEET 1 OF 1</p>	
<p>F:\DWG\MISC\MKTG\EGBF-RA-20-MKT.SLDDRW</p>			