

DO NOT SCALE FROM THIS PRINT

HDAF-XX-XX.X-X-13-X-X-XX

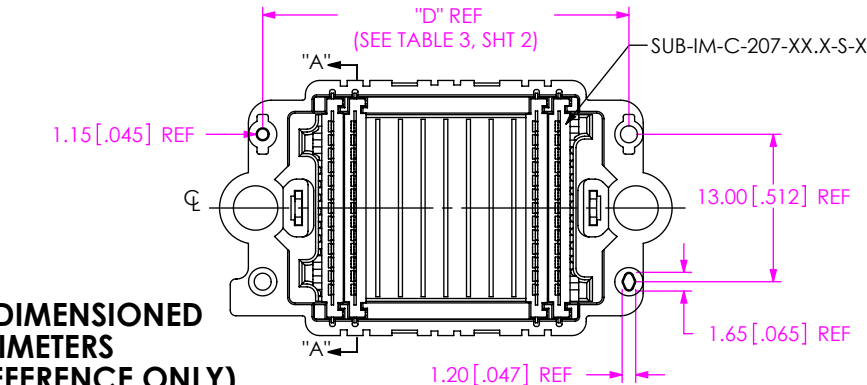
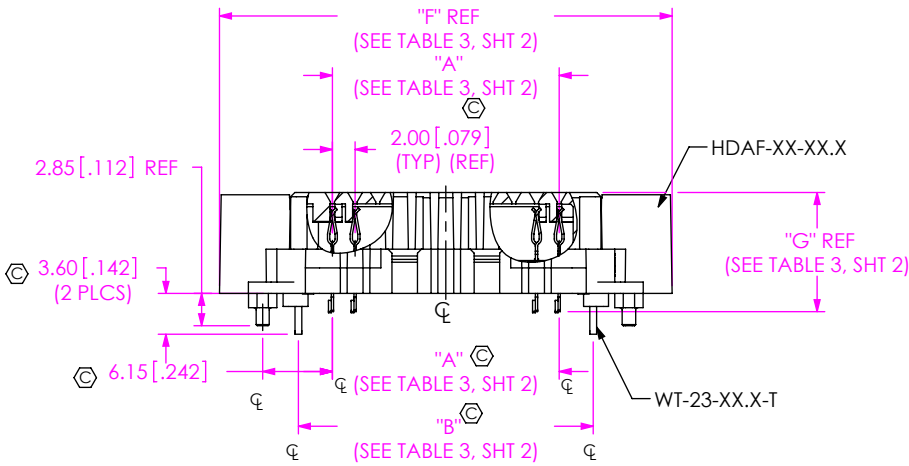
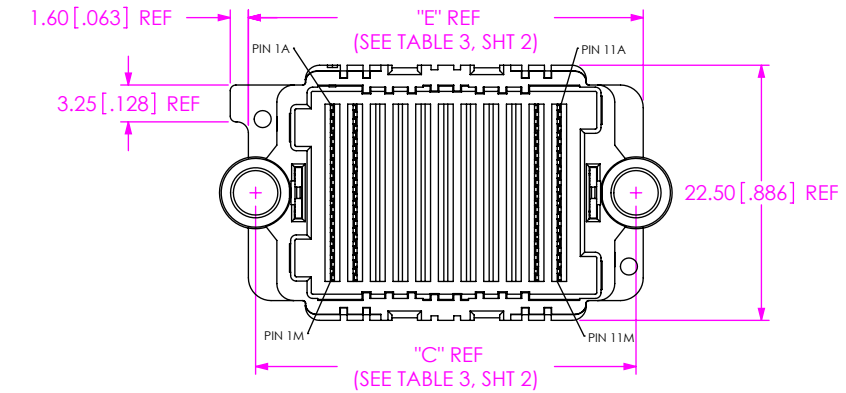

PACKAGING
 BLANK: TRAY (SEE NOTES 5 & 6)
 -TR: TAPE & REEL (SEE NOTES 6,7&8)
 -FR: FULL REEL QTY TAPE & REEL (SEE NOTES 6,7&8)

PICK & PLACE OPTION
 -P: PICK & PLACE PAD (USE MPP-26-01-N, SEE FIG 2, SHT 2)

SOLDER CHARGE MATERIAL
 -1: 63% TIN / 37% LEAD
 -2: 95.5% TIN / 3.8% SILVER 0.7% COPPER (LEAD FREE)

No OF POSITIONS
 (13 ROWS PER POSITION)
 -11
 -15
 -23

LEAD STYLE
 -08.0: 8MM
 -18.0: 18MM

PLATING SPECIFICATION
 -S: 30μ" GOLD IN MATING AREA, MATTE TIN ON TAIL AND WELD TABS

No OF ROWS
 -13

TABLE 1

STYLE	"BODY CALLOUT"	"CONTACT WAFER"	"SOLDER NAIL"
-08.0	HDAF-XX-08.0	SUB-IM-C-207-08.0-S-X	WT-23-08.0-T
-18.0	HDAF-XX-18.0	SUB-IM-C-207-18.0-S-X	WT-23-18.0-T

TABLE 2
STACK HEIGHT

HDAF LEAD STYLE	HDAM LEAD STYLE	
	-12.0	-17.0
-08.0	20.0MM	25.0MM
-18.0	30.0MM	35.0MM

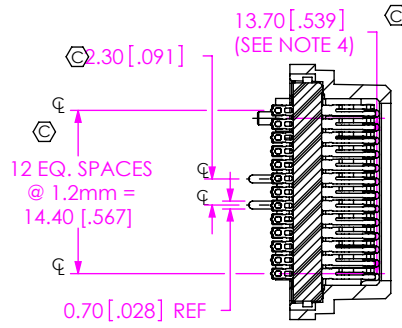
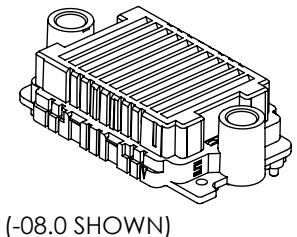
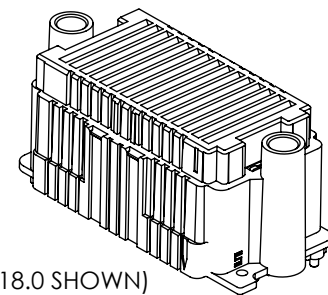

DESIGNED & DIMENSIONED IN MILLIMETERS (INCHES FOR REFERENCE ONLY)

FIG 1
 -11: 11 POSITION (HDAF-11-08.0-X-13-X-X SHOWN) (SOME WAFERS NOT SHOWN FOR CLARITY)

- NOTES:
1. REPRESENTS A CRITICAL DIMENSION.
 2. MINIMUM PUSHOUT FORCE: 2.22N [.5 LB]. FOR WAFERS AND WELD TABS.
 3. NOTE DELETED.
 4. DIMENSION FROM ϕ OF END TAIL TO ϕ OF -A PIN.
 5. TRAYS ARE STANDARD PACKAGING.
 6. ORDERS WILL BE PACKAGED ACCORDING TO THE SAMTEC PACKAGING EFFICIENCY STANDARDS (SPES) FOUND ON WWW.SAMTEC.COM.
 7. ATTACH LABEL - 4X2 TO EACH REEL.
 8. -18.0 LEAD STYLE NOT AVAILABLE IN -TR OR -FR

<p>UNLESS OTHERWISE SPECIFIED, DIMENSIONS ARE IN MILLIMETERS [INCHES].</p> <p>TOLERANCES ARE:</p> <p>DECIMALS ANGLES</p> <p>X: +0.3 [.01] 2°</p> <p>XX: ±0.13 [.005]</p> <p>XXX: ±0.051 [.0020]</p>	<p>PROPRIETARY NOTE</p> <p>THIS DOCUMENT CONTAINS CONFIDENTIAL AND PROPRIETARY INFORMATION AND ALL DESIGN, MANUFACTURING, REPRODUCTION, USE, PATENT RIGHTS AND SALES RIGHTS ARE EXPRESSLY RESERVED BY SAMTEC, INC. THIS DOCUMENT SHALL NOT BE DISCLOSED, IN WHOLE OR PART, TO ANY UNAUTHORIZED PERSON OR ENTITY NOR REPRODUCED, TRANSFERRED OR INCORPORATED IN ANY OTHER PROJECT IN ANY MANNER WITHOUT THE EXPRESS WRITTEN CONSENT OF SAMTEC, INC.</p>	<p>520 PARK EAST BLVD, NEW ALBANY, IN 47150 PHONE: 812-944-6733 FAX: 812-948-5047 e-Mail: info@SAMTEC.com code: 55322</p>

TABLE 3								
No. OF POS.	LEAD STYLE	"A"	"B"	"C"	"D"	"E"	"F"	"G"
11	08.0	20.0 [.787]	26.0 [1.02]	33.55 [1.321]	32.30 [1.272]	34.82 [1.371]	39.92 [1.572]	10.51 [.414]
15	08.0	28.0 [1.102]	34.0 [1.34]	41.55 [1.636]	40.30 [1.587]	42.82 [1.686]	47.92 [1.887]	10.51 [.414]
23	08.0	44.0 [1.732]	50.0 [1.97]	57.55 [2.266]	56.30 [2.217]	58.82 [2.316]	63.92 [2.517]	10.51 [.414]
11	18.0	20.0 [.787]	26.0 [1.02]	33.55 [1.321]	32.30 [1.272]	34.82 [1.371]	39.92 [1.572]	20.51 [.807]
15	18.0	28.0 [1.102]	34.0 [1.34]	41.55 [1.636]	40.30 [1.587]	42.82 [1.686]	47.92 [1.887]	20.51 [.807]
23	18.0	44.0 [1.732]	50.0 [1.97]	57.55 [2.266]	56.30 [2.217]	58.82 [2.316]	63.92 [2.517]	20.51 [.807]

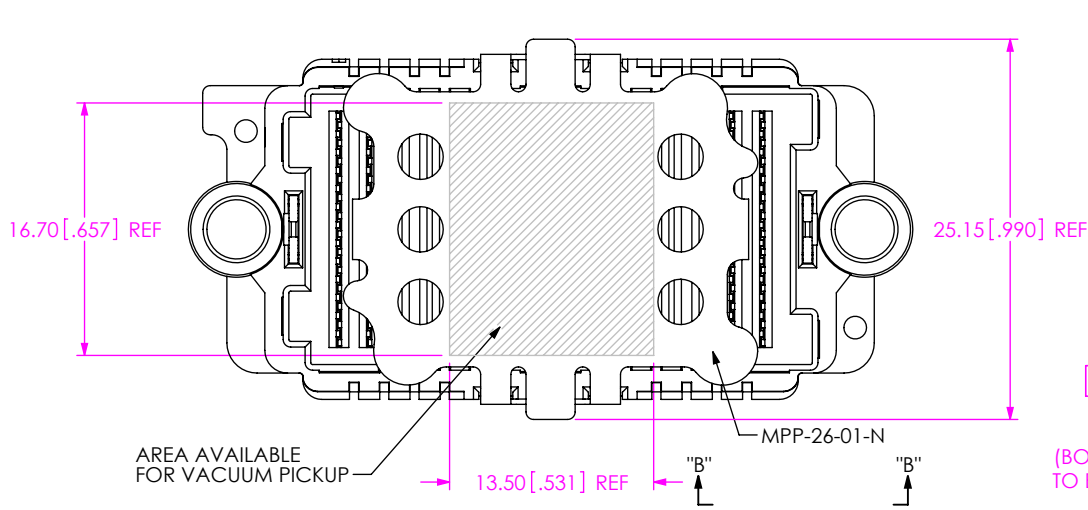
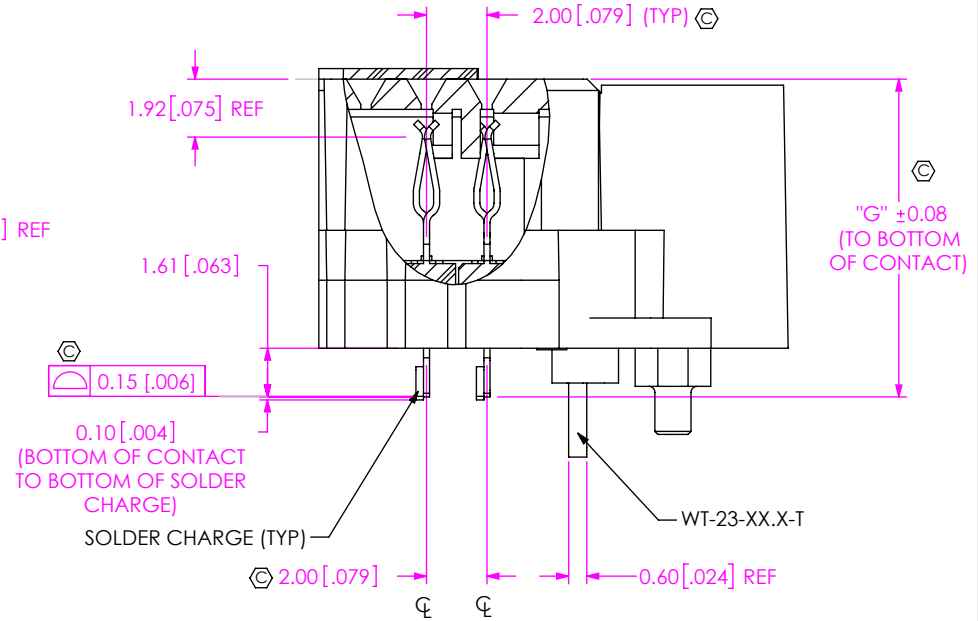
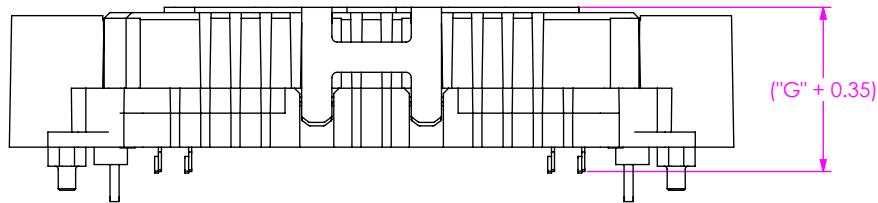

FIG 2
-15: 15 POSITION
(HDAF-15-08.0-X-13-X-P SHOWN)
(SOME WAFERS NOT SHOWN FOR CLARITY)



VIEW "B"- "B"
SCALE 4:1

F:\DWG\MISC\MKTG\HDAF-XX-XX.X-X-13-X-X-XX-MKT.SLDDRW

PROPRIETARY NOTE
THIS DOCUMENT CONTAINS CONFIDENTIAL AND PROPRIETARY INFORMATION AND ALL DESIGN, MANUFACTURING, REPRODUCTION, USE, PATENT RIGHTS AND SALES RIGHTS ARE EXPRESSLY RESERVED BY SAMTEC, INC. THIS DOCUMENT SHALL NOT BE DISCLOSED, IN WHOLE OR PART, TO ANY UNAUTHORIZED PERSON OR ENTITY NOR REPRODUCED, TRANSFERRED OR INCORPORATED IN ANY OTHER PROJECT IN ANY MANNER WITHOUT THE EXPRESS WRITTEN CONSENT OF SAMTEC, INC.

DO NOT SCALE DRAWING

SHEET SCALE: 1:1

samtec

520 PARK EAST BLVD, NEW ALBANY, IN 47150
PHONE: 812-944-6733 FAX: 812-948-5047
e-Mail: info@SAMTEC.com code: 55322

DESCRIPTION:
2.0MM PITCH HD ARRAY SOCKET ASSEMBLY

DWG. NO. HDAF-XX-XX.X-X-13-X-X-XX

BY:D KNOWLDEN 7/14/2005 SHEET 2 OF 3

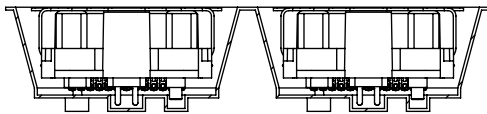
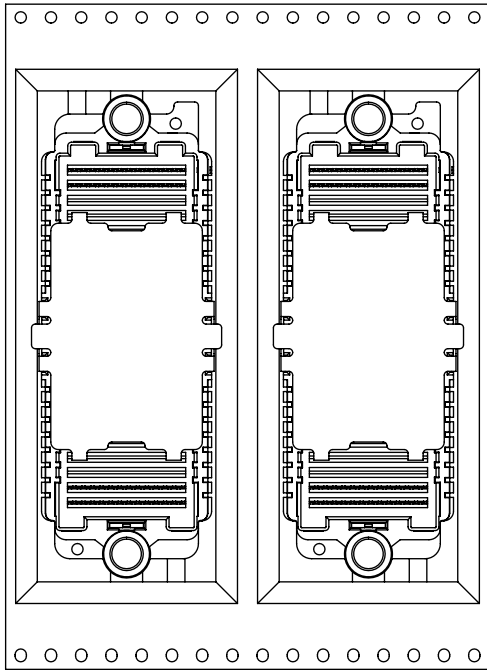

USER DIRECTION OF UNREELING →
POCKET NOT DETAILED

-TR PACKAGING VIEW

PROPRIETARY NOTE

THIS DOCUMENT CONTAINS CONFIDENTIAL AND PROPRIETARY INFORMATION AND ALL DESIGN, MANUFACTURING, REPRODUCTION, USE, PATENT RIGHTS AND SALES RIGHTS ARE EXPRESSLY RESERVED BY SAMTEC, INC. THIS DOCUMENT SHALL NOT BE DISCLOSED, IN WHOLE OR PART, TO ANY UNAUTHORIZED PERSON OR ENTITY NOR REPRODUCED, TRANSFERRED OR INCORPORATED IN ANY OTHER PROJECT IN ANY MANNER WITHOUT THE EXPRESS WRITTEN CONSENT OF SAMTEC, INC.

DO NOT SCALE DRAWING

SHEET SCALE: 1:1



520 PARK EAST BLVD, NEW ALBANY, IN 47150
PHONE: 812-944-6733 FAX: 812-948-5047
e-Mail: info@SAMTEC.com code: 55322

DESCRIPTION:
2.0MM PITCH HD ARRAY SOCKET ASSEMBLY

DWG. NO.
HDAF-XX-XX.X-X-13-X-X-XX

BY: D KNOWLDEN 7/14/2005 SHEET 3 OF 3