

**DESIGNED AND DIMENSIONED  
IN MILLIMETERS [INCHES]**

DO NOT  
SCALE FROM  
THIS PRINT

**HDTM-3-XX-X-X-VT-X-X-X-X-X**

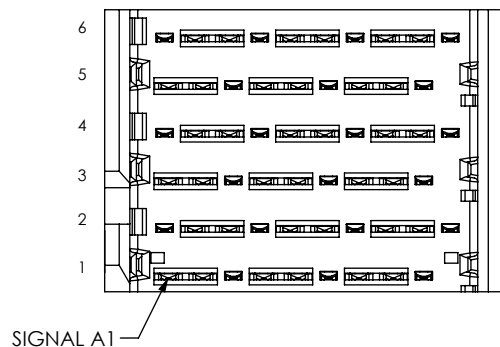

PAIRS PER COLUMN

-3

No. OF COLUMNS

-04

-06

-08

COMPLIANT TAIL SIZE

-1: 0.0177" DRILL

-2: 0.0217" DRILL

PLATING

-S: 30µ" SELECTIVE GOLD  
IN CONTACT AREA,  
MATTE TIN ON TAIL

ORIENTATION

-VT: VERTICAL

SIDE WALL OPTIONS

-0: OPEN (NO WALLS)

-1: LEFT SIDE WALL (SEE FIG 2, SHT 3)

-2: RIGHT SIDEWALL (SEE FIG 3, SHT 3)

-4: LEFT POLARIZING W/ LEFT GUIDANCE (SEE FIG 4, SHT 4)

-5: RIGHT POLARIZING W/ RIGHT GUIDANCE (SEE FIG 5, SHT 5)

END WALL OPTIONS

-BLANK: STANDARD

KEYING (ONLY AVAILABLE WITH -4 OR -5 POLARIZING)

-BLANK: NO KEYING

-A THRU -H: DENOTES POSITION OF FLAT ON KEY  
(SEE TABLE 7, SHT 5)

STAGE COMBINATIONS

-1: 3mm WIPE SIGNAL / 4mm WIPE GROUND

-2: 2mm WIPE SIGNAL / 4mm WIPE GROUND

-3: 3mm WIPE SIGNAL / 3mm WIPE GROUND

-4: 2mm WIPE SIGNAL / 3mm WIPE GROUND

-5: 2mm WIPE SIGNAL / 2mm WIPE GROUND

GUIDANCE (ONLY AVAILABLE WITH -4 OR -5 POLARIZING)

-BLANK: NONE

-L: LEFT SIDE GUIDE PIN (SEE FIG 5, SHT 4)

-R: RIGHT SIDE GUIDE PIN (SEE FIG 6, SHT 5)

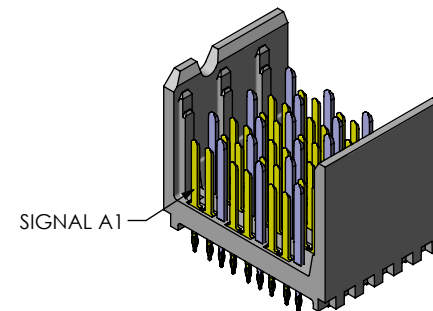
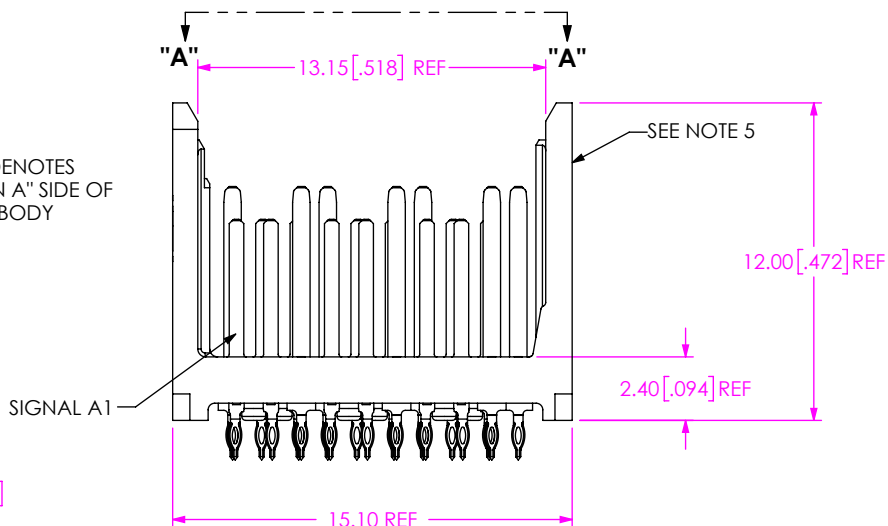
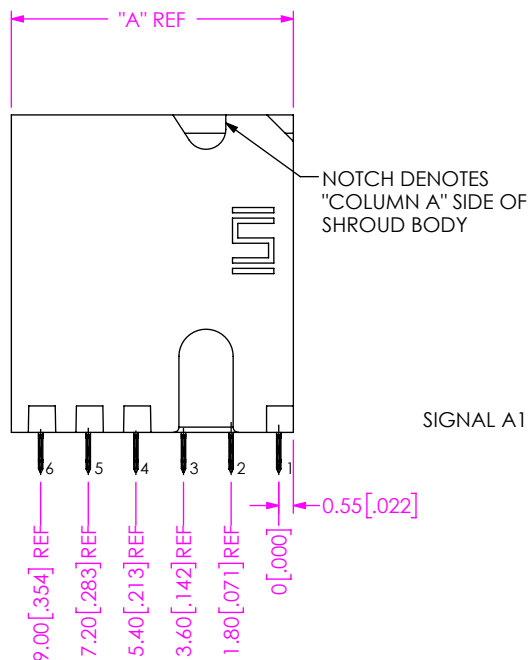

OPEN (NO WALLS) SHOWN

FIG 1  
OPEN (NO WALL) OPTION  
(HDTM-3-06-X-X-VT-0-X SHOWN)

COLUMNS	"A"
-04	7.06 [0.278]
-06	10.66 [0.420]
-08	14.26 [0.561]

NOTES:

1. MINIMUM PUSHOUT FORCE: 2.22N.
2. #2-56 SCREW W/ SQUARE CONICAL WASHER MUST BE INSTALLED FOR GROUNDED POLARIZING PIN. FOR NON-GROUNDED POLARIZING PINS, SCREW & WASHER MAY BE INSTALLED FOR ADDITIONAL STRENGTH. SCREW LENGTH TO BE A MAXIMUM OF 8.00mm ABOVE PCB SURFACE
3. CONTACT SAMTEC FOR CONNECTOR PRESS FIT INSTRUCTIONS AND REQUIRED FIXTURES.
4. TRAYS TO BE STANDARD PACKAGING.
5. MARK SAMTEC P/N AND DATE CODE ON THIS SURFACE.
6. ORDERS WILL BE PACKAGED ACCORDING TO THE SAMTEC PACKAGING EFFICIENCY STANDARDS (SPES) FOUND ON WWW.SAMTEC.COM

UNLESS OTHERWISE SPECIFIED,  
DIMENSIONS ARE IN MILLIMETERS  
TOLERANCES ARE:  
DECIMALS ANGLES  
X.X: ±0.3 2°  
X.XX: ±0.13  
X.XXX: ±0.051

**PROPRIETARY NOTE**  
THIS DOCUMENT CONTAINS CONFIDENTIAL AND PROPRIETARY INFORMATION AND ALL DESIGN, MANUFACTURING, REPRODUCTION, USE, PATENT RIGHTS AND SALES RIGHTS ARE EXPRESSLY RESERVED BY SAMTEC, INC. THIS DOCUMENT SHALL NOT BE DISCLOSED, IN WHOLE OR PART, TO ANY UNAUTHORIZED PERSON OR ENTITY NOR REPRODUCED, TRANSFERRED OR INCORPORATED IN ANY OTHER PROJECT IN ANY MANNER WITHOUT THE EXPRESS WRITTEN CONSENT OF SAMTEC, INC.

MATERIAL:  
INSULATOR: LCP  
TERMINAL: PHOS BRONZE

DO NOT SCALE DRAWING  
SHEET SCALE: 2:1



520 PARK EAST BLVD, NEW ALBANY, IN 47150  
PHONE: 812-944-6733 FAX: 812-948-5047  
e-Mail: info@SAMTEC.com code 55322

DESCRIPTION:  
XCede? HDTM VERTICAL BACKPLANE ASSEMBLY

DWG. NO.  
**HDTM-3-XX-X-X-VT-X-X-X-X-X**

BY: KNOWLDEN 11/21/2016 SHEET 1 OF 6

STAGE COMBINATIONS	"C"	"D"
-1: (3MM SIG / 4MM GND)	5.20 [0.205]	6.40 [0.252]
-2: (2MM SIG / 4MM GND)	4.20 [0.165]	6.40 [0.252]
-3: (3MM SIG / 3MM GND)	5.20 [0.205]	5.40 [0.213]
-4: (2MM SIG / 3MM GND)	4.20 [0.165]	5.40 [0.213]
-5: (2MM SIG / 2MM GND)	4.20 [0.165]	4.40 [0.173]

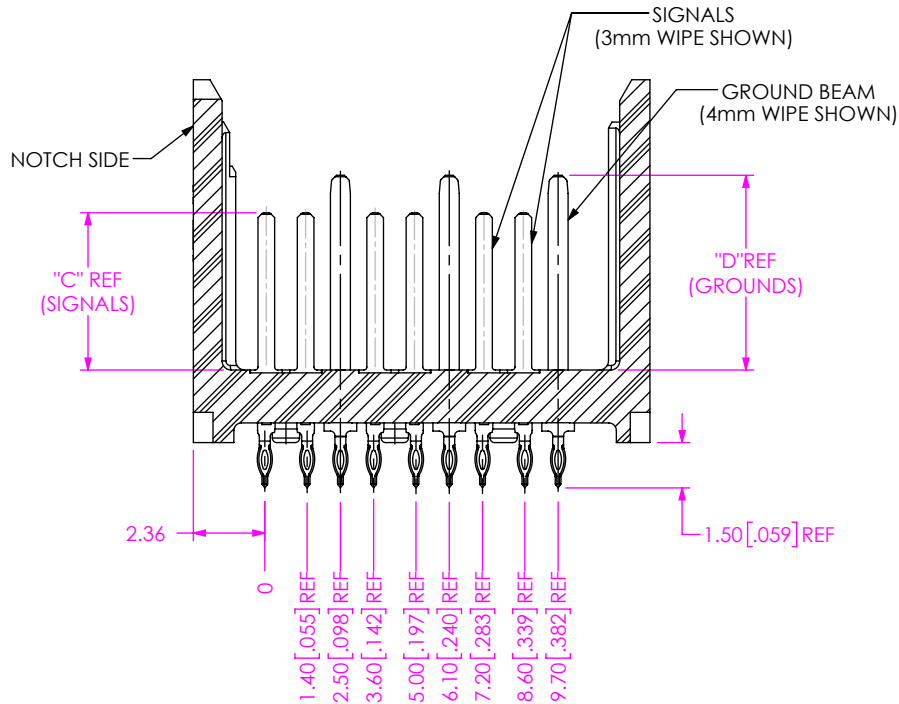
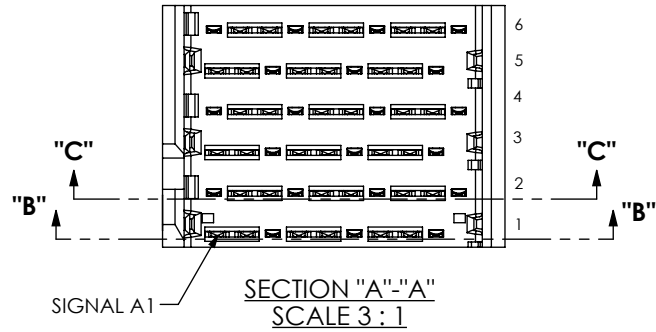

SECTION "B"-"B"  
SCALE 4 : 1  
(ROW 1)

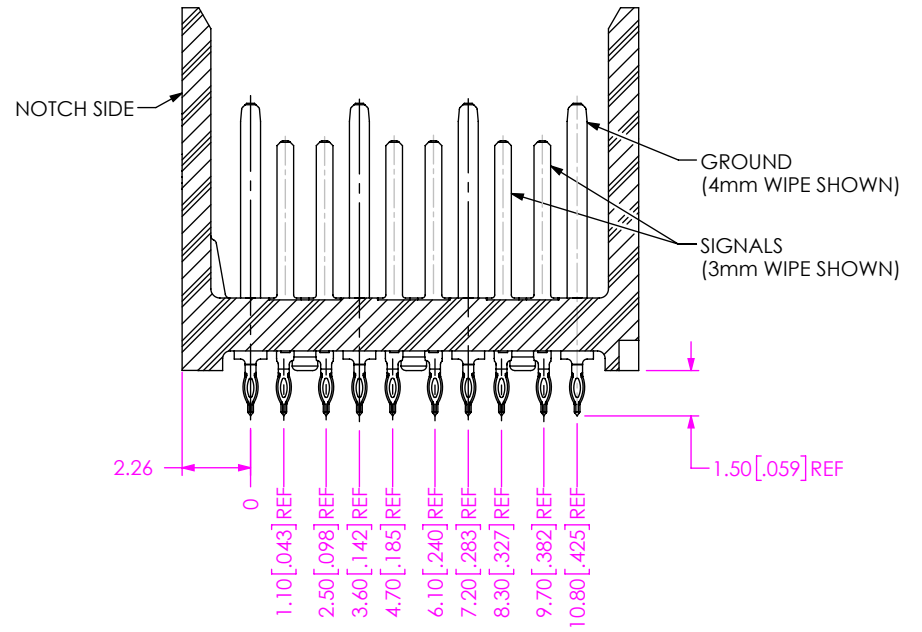

SECTION "C"-"C"  
SCALE 4 : 1  
(ROW 2)

**PROPRIETARY NOTE**  
THIS DOCUMENT CONTAINS CONFIDENTIAL AND PROPRIETARY INFORMATION AND ALL DESIGN, MANUFACTURING, REPRODUCTION, USE, PATENT RIGHTS AND SALES RIGHTS ARE EXPRESSLY RESERVED BY SAMTEC, INC. THIS DOCUMENT SHALL NOT BE DISCLOSED, IN WHOLE OR PART, TO ANY UNAUTHORIZED PERSON OR ENTITY NOR REPRODUCED, TRANSFERRED OR INCORPORATED IN ANY OTHER PROJECT IN ANY MANNER WITHOUT THE EXPRESS WRITTEN CONSENT OF SAMTEC, INC.

**samtec**  
520 PARK EAST BLVD, NEW ALBANY, IN 47150  
PHONE: 812-944-6733 FAX: 812-948-5047  
e-Mail info@SAMTEC.com code 55322

DO NOT SCALE DRAWING  
SHEET SCALE: 2:1

DESCRIPTION:  
XCede? HDTM VERTICAL BACKPLANE ASSEMBLY  
DWG. NO.  
HDTM-3-XX-X-X-VT-X-X-X-X-X  
BY: KNOWLDEN 11/21/2016 SHEET 2 OF 6

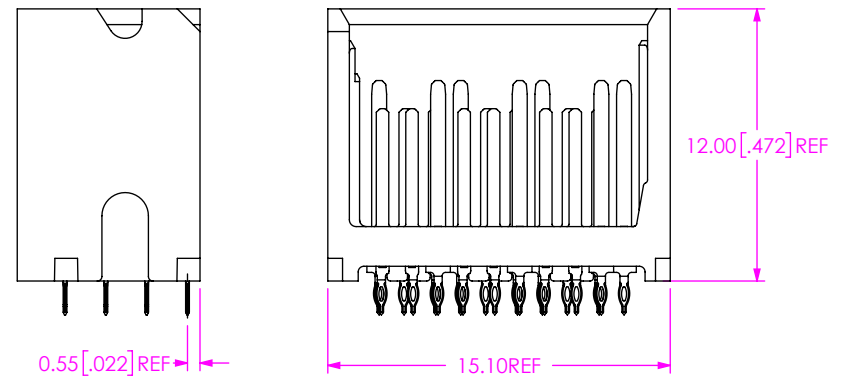
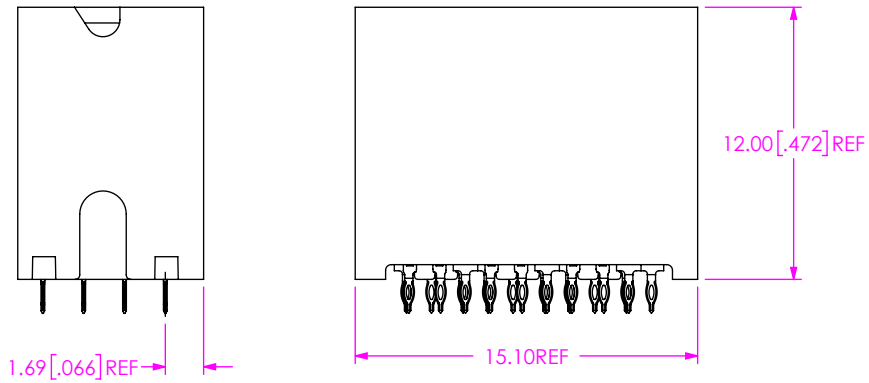
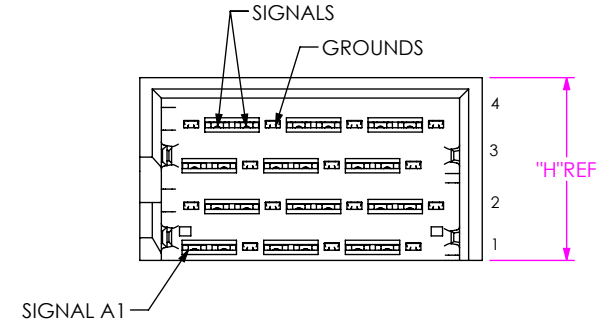
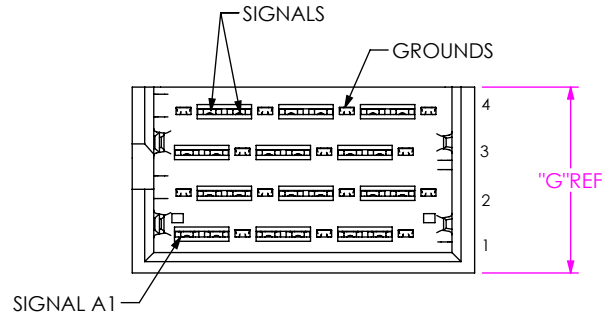
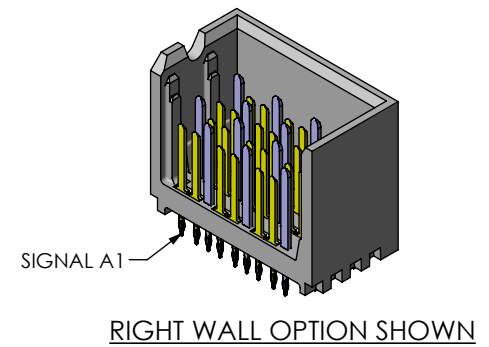
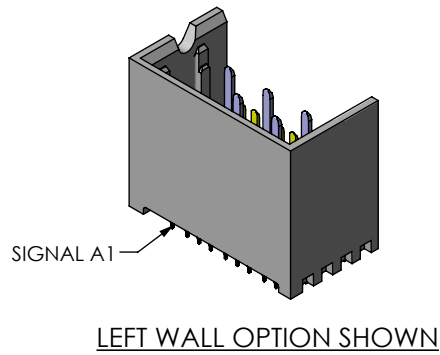

FIG 2  
LEFT WALL OPTION  
(HDTM-3-XX-X-X-VT-1-X SHOWN)  
(SAME AS FIG 1, EXCEPT AS SHOWN)

FIG 3  
RIGHT WALL OPTION  
(HDTM-3-XX-X-X-VT-2-X SHOWN)  
(SAME AS FIG 1, EXCEPT AS SHOWN)

COLUMNS	"G"	"H"
-04	8.20 [0.323]	8.06 [0.317]
-06	11.80 [0.465]	11.66 [0.459]
-08	15.40 [0.606]	15.26 [0.601]

**PROPRIETARY NOTE**  
THIS DOCUMENT CONTAINS CONFIDENTIAL AND PROPRIETARY INFORMATION AND ALL DESIGN, MANUFACTURING, REPRODUCTION, USE, PATENT RIGHTS AND SALES RIGHTS ARE EXPRESSLY RESERVED BY SAMTEC, INC. THIS DOCUMENT SHALL NOT BE DISCLOSED, IN WHOLE OR PART, TO ANY UNAUTHORIZED PERSON OR ENTITY NOR REPRODUCED, TRANSFERRED OR INCORPORATED IN ANY OTHER PROJECT IN ANY MANNER WITHOUT THE EXPRESS WRITTEN CONSENT OF SAMTEC, INC.



520 PARK EAST BLVD, NEW ALBANY, IN 47150  
PHONE: 812-944-6733 FAX: 812-948-5047  
e-Mail info@SAMTEC.com code 55322

DO NOT SCALE DRAWING

SHEET SCALE: 5:1

DESCRIPTION:  
XCede? HDTM VERTICAL BACKPLANE ASSEMBLY

DWG. NO.  
HDTM-3-XX-X-X-VT-X-X-X-X-X

BY: KNOWLDEN 11/21/2016 SHEET 3 OF 6

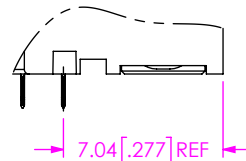
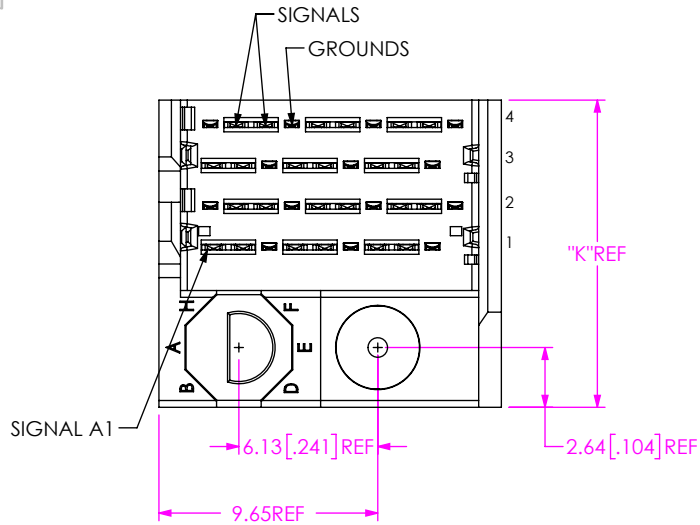

SECTION "D"-D"  
SCALE 3 : 1

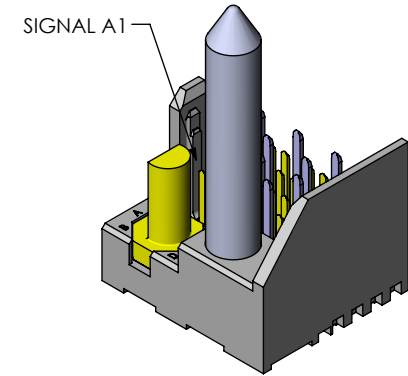

LEFT POLARIZING  
OPTION SHOWN

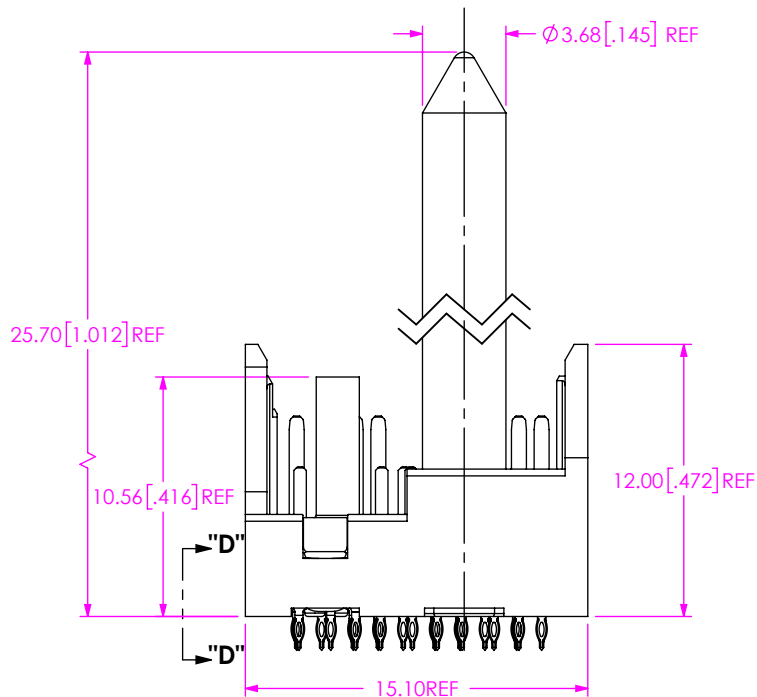

PRINTED CIRCUIT BOARD  
**-NOT SUPPLIED**  
(SEE HDTM-3-XX-X-X-VT-X-X-X-X-FOOTPRINT  
DRAWING FOR DETAILS)

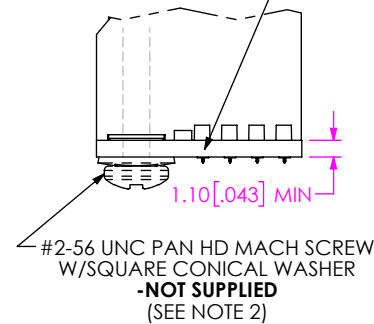

TABLE 5	
COLUMNS	"K"
-04	13.54 [0.533]
-06	17.14 [0.675]
-08	20.74 [0.817]

FIG 4  
LEFT POLARIZING OPTION  
(HDTM-3-XX-X-X-VT-4-L-X-A SHOWN)  
(SAME AS FIG 1, EXCEPT AS SHOWN)

**PROPRIETARY NOTE**  
THIS DOCUMENT CONTAINS CONFIDENTIAL AND PROPRIETARY INFORMATION AND ALL DESIGN, MANUFACTURING, REPRODUCTION, USE, PATENT RIGHTS AND SALES RIGHTS ARE EXPRESSLY RESERVED BY SAMTEC, INC. THIS DOCUMENT SHALL NOT BE DISCLOSED, IN WHOLE OR PART, TO ANY UNAUTHORIZED PERSON OR ENTITY NOR REPRODUCED, TRANSFERRED OR INCORPORATED IN ANY OTHER PROJECT IN ANY MANNER WITHOUT THE EXPRESS WRITTEN CONSENT OF SAMTEC, INC.



520 PARK EAST BLVD, NEW ALBANY, IN 47150  
PHONE: 812-944-6733 FAX: 812-948-5047  
e-Mail info@SAMTEC.com code 55322

DO NOT SCALE DRAWING

SHEET SCALE: 5:1

DESCRIPTION:  
XCede? HDTM VERTICAL BACKPLANE ASSEMBLY  
DWG. NO.  
HDTM-3-XX-X-X-VT-X-X-X-X

BY: KNOWLDEN 11/21/2016 SHEET 4 OF 6

TABLE 7

GUIDANCE	KEYING							
-BLANK	-BLANK							
-L / -R	-A	-B	-C	-D	-E	-F	-G	-H

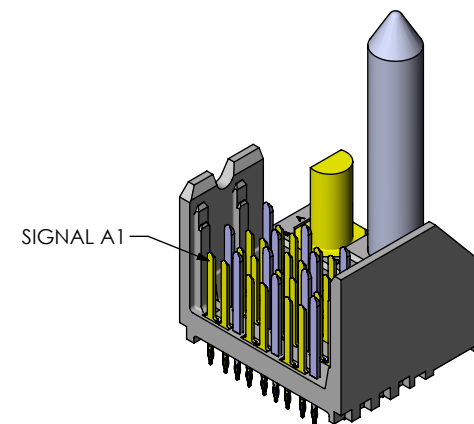
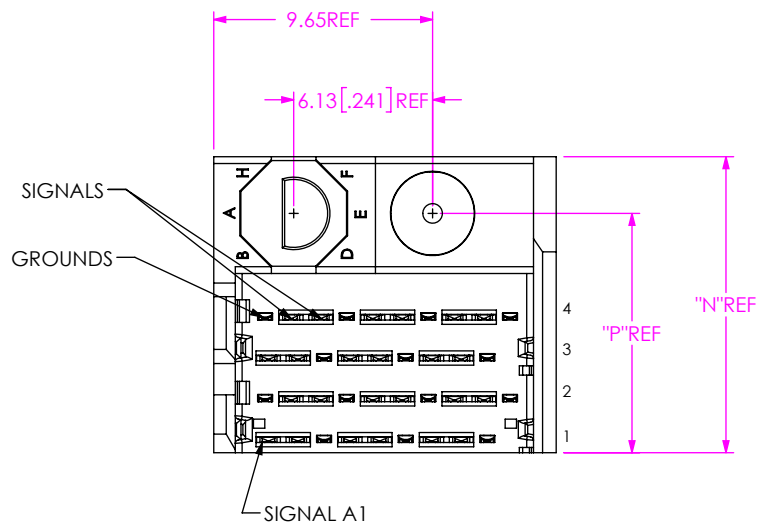

RIGHT POLARIZING  
OPTION SHOWN

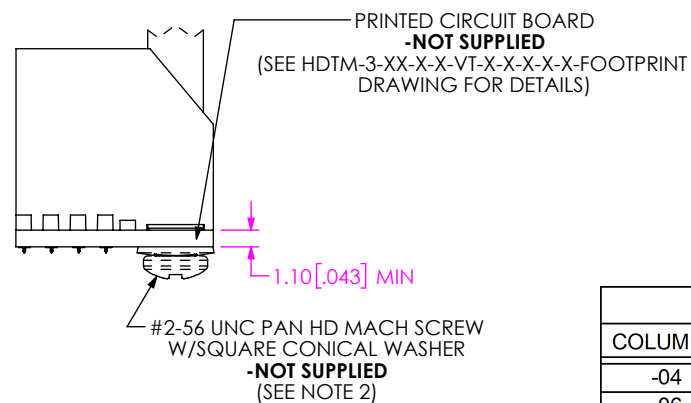
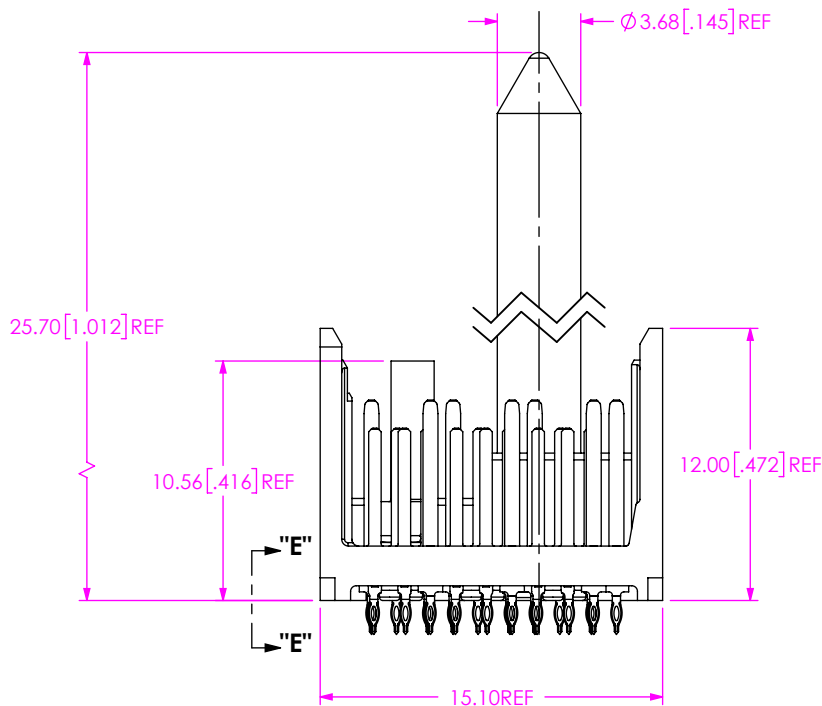

TABLE 6

COLUMNS	"N"	"P"
-04	13.05 [0.514]	10.56 [0.416]
-06	16.65 [0.656]	14.16 [0.557]
-08	20.25 [0.797]	17.76 [0.699]

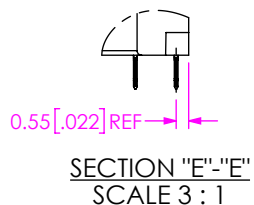

FIG 5  
RIGHT POLARIZING OPTION  
(HDTM-3-XX-X-X-VT-5-R-X-A SHOWN)  
(SAME AS FIG 1, EXCEPT AS SHOWN)

PROPRIETARY NOTE  
THIS DOCUMENT CONTAINS CONFIDENTIAL AND PROPRIETARY INFORMATION AND ALL DESIGN, MANUFACTURING, REPRODUCTION, USE, PATENT RIGHTS AND SALES RIGHTS ARE EXPRESSLY RESERVED BY SAMTEC, INC. THIS DOCUMENT SHALL NOT BE DISCLOSED, IN WHOLE OR PART, TO ANY UNAUTHORIZED PERSON OR ENTITY NOR REPRODUCED, TRANSFERRED OR INCORPORATED IN ANY OTHER PROJECT IN ANY MANNER WITHOUT THE EXPRESS WRITTEN CONSENT OF SAMTEC, INC.

DO NOT SCALE DRAWING  
SHEET SCALE: 5:1



520 PARK EAST BLVD, NEW ALBANY, IN 47150  
PHONE: 812-944-6733 FAX: 812-948-5047  
e-Mail info@SAMTEC.com code 55322

DESCRIPTION:  
XCede<sup>®</sup> HDTM VERTICAL BACKPLANE ASSEMBLY  
DWG. NO.

HDTM-3-XX-X-X-VT-X-X-X-X-X

BY: KNOWLDEN 11/21/2016 SHEET 5 OF 6

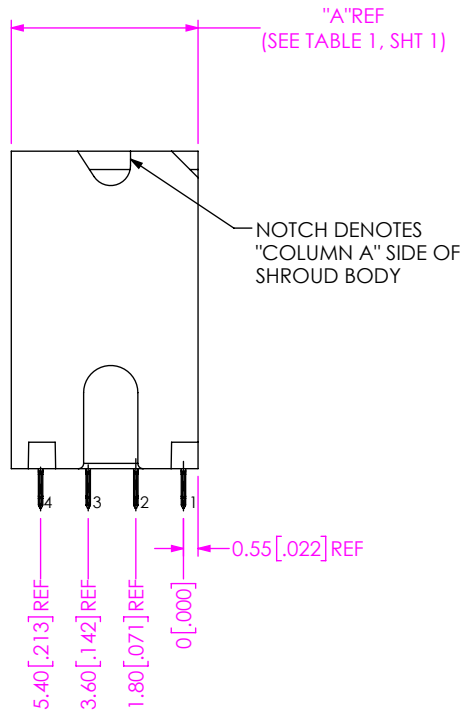

FIG 6  
OPEN-NO WALL OPTION  
(HDTM-3-04-X-X-VT-0-X SHOWN)  
(SAME AS FIG 1, EXCEPT AS SHOWN)

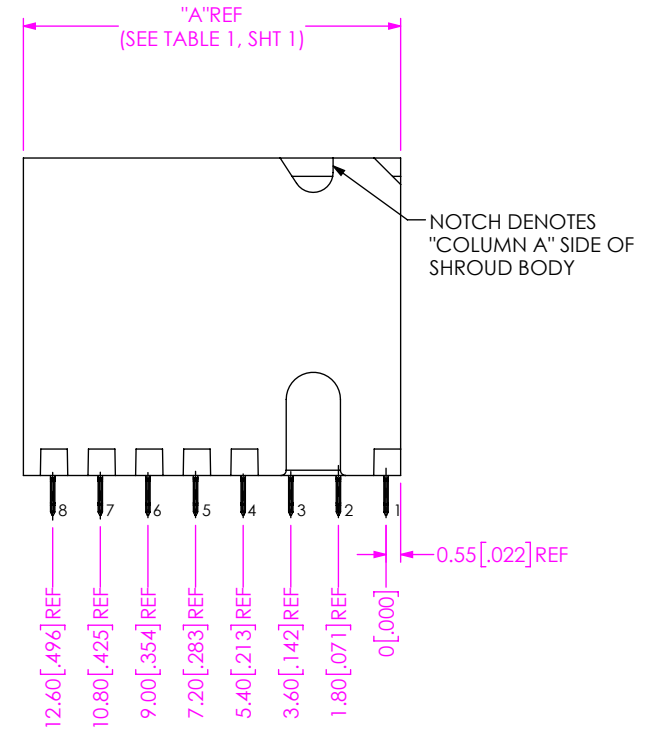



FIG 7  
OPEN-NO WALL OPTION  
(HDTM-3-08-X-X-VT-0-X SHOWN)  
(SAME AS FIG 1, EXCEPT AS SHOWN)

<p><b>PROPRIETARY NOTE</b></p> <p>THIS DOCUMENT CONTAINS CONFIDENTIAL AND PROPRIETARY INFORMATION AND ALL DESIGN, MANUFACTURING, REPRODUCTION, USE, PATENT RIGHTS AND SALES RIGHTS ARE EXPRESSLY RESERVED BY SAMTEC, INC. THIS DOCUMENT SHALL NOT BE DISCLOSED, IN WHOLE OR PART, TO ANY UNAUTHORIZED PERSON OR ENTITY NOR REPRODUCED, TRANSFERRED OR INCORPORATED IN ANY OTHER PROJECT IN ANY MANNER WITHOUT THE EXPRESS WRITTEN CONSENT OF SAMTEC, INC.</p>	 <p>520 PARK EAST BLVD, NEW ALBANY, IN 47150 PHONE: 812-944-6733 FAX: 812-948-5047 e-Mail info@SAMTEC.com code 55322</p>
<p>DO NOT SCALE DRAWING</p> <p>SHEET SCALE: 2:1</p>	<p>DESCRIPTION: XCede<sup>®</sup> HDTM VERTICAL BACKPLANE ASSEMBLY</p> <p>DWG. NO. HDTM-3-XX-X-X-VT-X-X-X-X-X</p> <p>BY: KNOWLDEN 11/21/2016 SHEET 6 OF 6</p>