

DO NOT
SCALE FROM
THIS PRINT

LENGTH
-100, -250, *-300
-400, *-500, *-600
*-1000

(*=OBSOLETE)

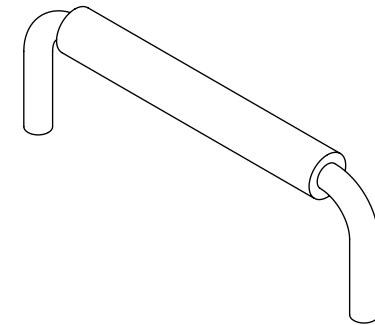
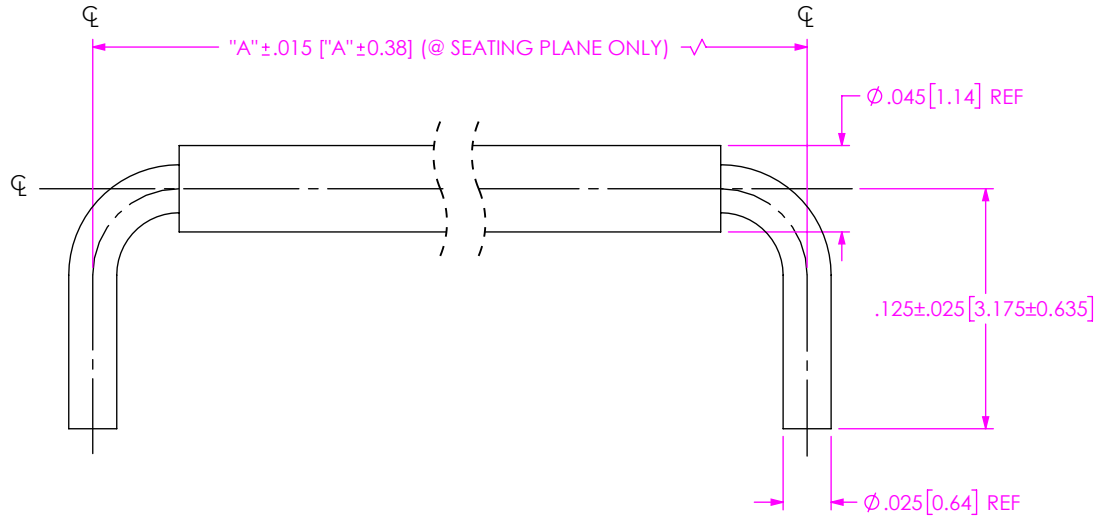

PART NO.	DIM "A"
JL-100-25-T	.100 [2.54]
JL-250-25-T	.250 [6.35]
*JL-300-25-T	.300 [7.62]
JL-400-25-T	.400 [10.16]
*JL-500-25-T	.500 [12.70]
*JL-600-25-T	.600 [15.24]
*JL-1000-25-T	1.000 [25.40]

*=OBSOLETE

NOTES:

1. REPRESENTS A CONTROL PLAN CRITICAL DIMENSION.
2. SHARP CORNERS CAN BE BROKEN WITH A 0.05 RADIUS OR 0.05 x 45° CHAMFER MAX, UNLESS OTHERWISE SPECIFIED.
3. FABRICATED PARTS MUST BE FREE OF SCRATCHES, TOOL MARKS, BURRS, ETC.
4. SEE PLATING STANDARD CO-PL-FRM-7001-M.
5. MADE FROM UL-1213 RATED WIRE, WHICH IS RATED TO 600 VOLTS @ 200°C.

c:\enterprise\vaull\DWG\MISC\MKTG\JL-XXX-25-T-MKT.SLDDRW

<p>UNLESS OTHERWISE SPECIFIED, DIMENSIONS ARE IN INCHES [MILLIMETERS] TOLERANCES ARE: DECIMALS: .XX: ±.01 [2.54] .XXX: ±.005 [0.13] .XXXX: ±.0020 [0.051] ANGLES: ±5°</p>	<p>PROPRIETARY NOTE THIS DOCUMENT CONTAINS CONFIDENTIAL AND PROPRIETARY INFORMATION AND ALL DESIGN, MANUFACTURING, REPRODUCTION, USE, PATENT RIGHTS AND SALES RIGHTS ARE EXPRESSLY RESERVED BY SAMTEC, INC. THIS DOCUMENT SHALL NOT BE DISCLOSED, IN WHOLE OR PART, TO ANY UNAUTHORIZED PERSON OR ENTITY NOR REPRODUCED, TRANSFERRED OR INCORPORATED IN ANY OTHER PROJECT IN ANY MANNER WITHOUT THE EXPRESS WRITTEN CONSENT OF SAMTEC, INC.</p>		
		<p>520 PARK EAST BLVD., NEW ALBANY, IN 47150 PHONE: 812-944-6733 FAX: 812-948-5047 e-Mail: info@SAMTEC.com code 55322</p>	
<p>MATERIAL: DO NOT SCALE DRAWING SHEET SCALE: 10:1</p> <p>INSULATOR: WHITE TEFLON UL FLAME TESTED: VW-1 WIRE: 22 GAUGE COPPER PLATING: AG PER MIL-QQW-343</p>	<p>DESCRIPTION: JUMPER LINK</p>	<p>DWG. NO. JL-XXX-25-T</p>	
<p>BY: ETHAN C 12/05/2018</p>		<p>SHEET 1 OF 1</p>	