

REVISION U

DO NOT SCALE FROM THIS PRINT

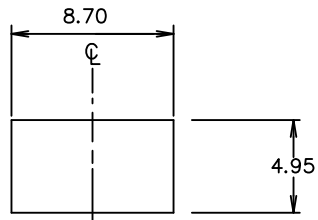

SUGGESTED PANEL CUTOUT DIMENSIONS

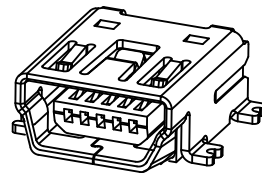

MUSB-05-X-A-SM-A-X-X-XX

NO. OF CONTACTS  
-05

PLATING

- F: 1 μ" FLASH GOLD ON CONTACT AREA, BRIGHT ACID TIN ON TAIL
- S: 30 μ" SELECTIVE GOLD ON CONTACT AREA, BRIGHT ACID TIN ON TAIL

TYPE  
-A

- OPTION
  - BLANK TRAYS (SEE NOTE 5)
  - TR: TAPE & REEL PACKAGING (SEE NOTE 7 & 8)
  - FR: FULL REEL QTY TAPE & REEL (SEE NOTE 7 & 8)
- PICK & PLACE PAD
  - K: KAPTON PAD
- E & I OPTION
  - R: RoHS COMPLIANT
- ALIGNMENT PINS
- RA TERMINATION
  - SM: SURFACE MOUNT

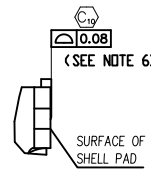
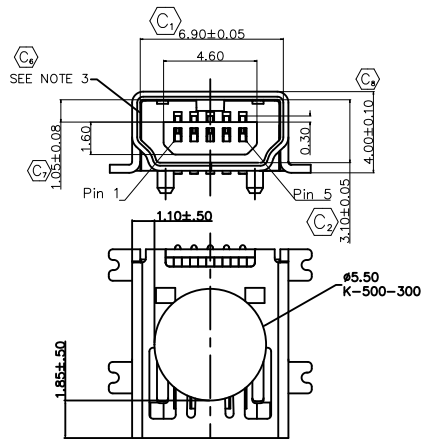
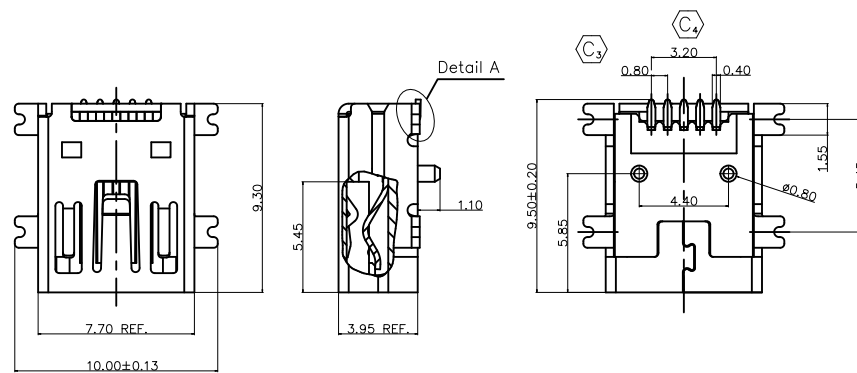

DETAIL A  
SCALE 2:1

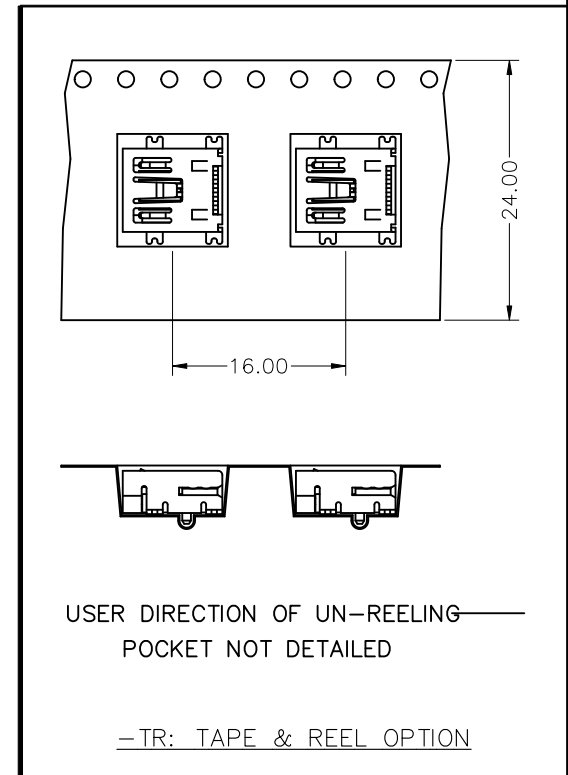
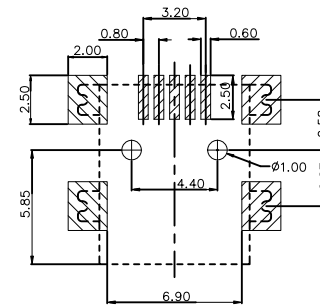

NOTES:

1. (C) REPRESENTS CRITICAL DIMENSION.
2. NOTE DELETED.
3. CONFIRM THAT PARTS FACE MATCH THIS PRINT.
4. ALL PARTS ARE RoHS COMPLIANT AS OF REVISION G.
5. PARTS TO BE PACKAGED LEADS DOWN IN TRAYS AS STANDARD.
6. COPLANARITY MEASUREMENT SHOULD INCLUDE ALL USB TAILS AND SHELL TABS.
7. ORDERS WILL BE PACKAGED ACCORDING TO THE SAMTEC PACKAGING EFFICIENCY STANDARDS (SPES) FOUND ON WWW.SAMTEC.COM
8. ATTACH LABEL TO EACH REEL

UNLESS OTHERWISE SPECIFIED, DIMENSIONS ARE IN MM. TOLERANCES ARE:

DECIMALS ANGLES  
.X: ±.25 2°  
.XX: ±.13  
.XXX: ±.05

PROPRIETARY NOTE

THIS DOCUMENT CONTAINS CONFIDENTIAL AND PROPRIETARY INFORMATION AND ALL DESIGN, MANUFACTURING, REPRODUCTION, USE, PATENT RIGHTS AND SALES RIGHTS ARE EXPRESSLY RESERVED BY SAMTEC, INC. THIS DOCUMENT SHALL NOT BE DISCLOSED, IN WHOLE OR PART, TO ANY UNAUTHORIZED PERSON OR ENTITY NOR REPRODUCED, TRANSFERRED OR INCORPORATED IN ANY OTHER PRODUCT IN ANY MANNER WITHOUT THE EXPRESS WRITTEN CONSENT OF SAMTEC, INC.

DO NOT SCALE DRAWING  
INSULATOR: PA6T, RATED UL 94V-0, BLACK  
CONTACT: PHOS BRONZE  
SHELL: CU/NI PLATED BRASS

SHEET SCALE: 1:2

MAX FLASH ALLOWED: .051  
MAX GATE VESTIGE: .051  
F:\DWG\MISC\MKTG

DESCRIPTION:  
Mini USB, RA, 5 Pin, Type A, Single, SMT

DWG. NO.  
MUSB-05-X-A-SM-A-X-X-XX

BY: J. RILEY 03/24/04 SHEET 1 OF 1

CODE: 55322

520 PARK EAST BLVD. NEW ALBANY, IN 47150  
(812) 944-6733 P.O. BOX 1147 TWX: 810-540-4085