

DO NOT SCALE FROM THIS PRINT

DESIGNED & DIMENSIONED IN INCHES[MILLIMETERS]

PRFIA-185-P-P-S

ADAPTER TYPE
-IA: IN-SERIES ADAPTER

SERIES
-185: 1.85mm

END 1 GENDER
-P: PLUG

ORIENTATION
-S: STRAIGHT

END 2 GENDER
-P: PLUG

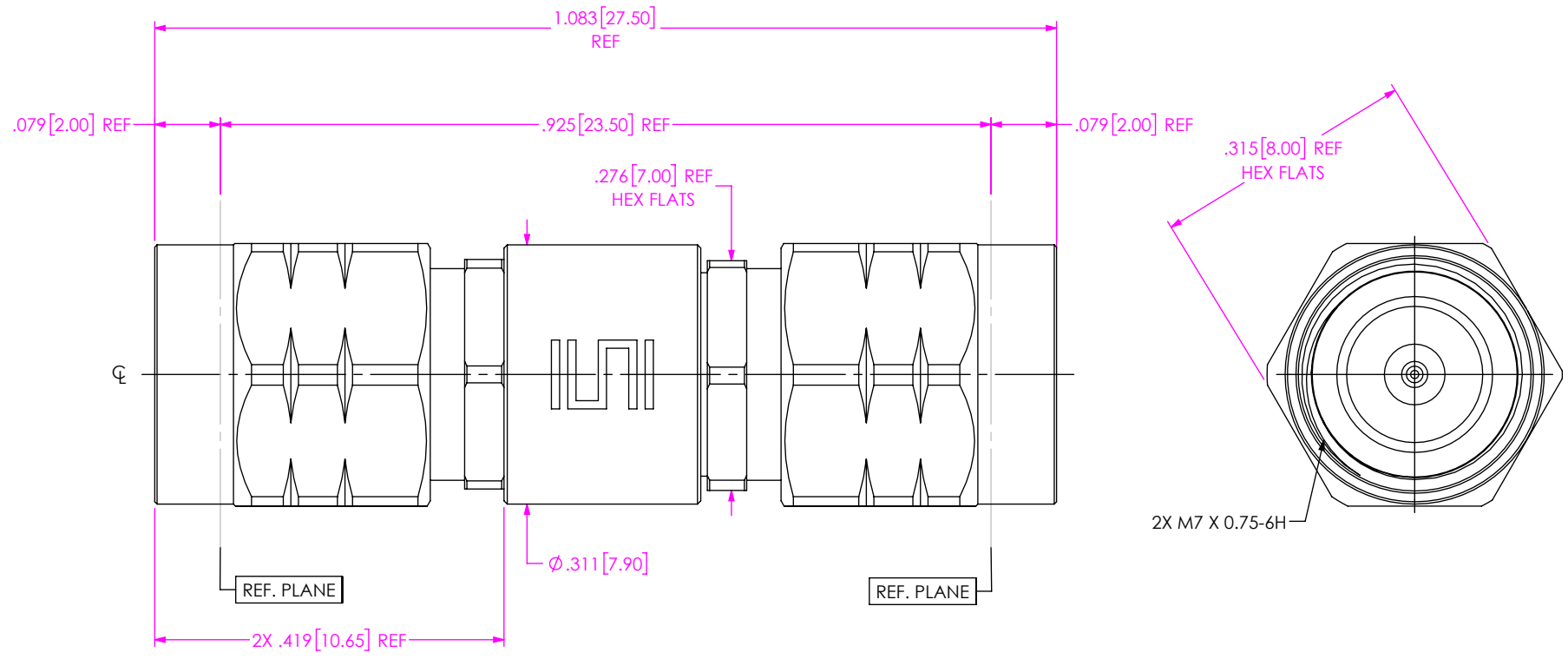

NOTES:

- MATERIAL:
BODY: STAINLESS STEEL
CONTACT: BERYLLIUM COPPER
BEAD: PEI
- FINISH:
BODY: PASSIVATED
CONTACT: GOLD
- VSWR DC – 67GHz ___ 1.30:1 MAX
- INSERTION LOSS .08XSQRT(MAX FREQ) MAX

UNLESS OTHERWISE SPECIFIED, DIMENSIONS ARE IN INCHES. TOLERANCES ARE: DECIMALS ANGLES .XX: \pm .01 [0.3] .XXX: \pm .005 [0.13] .XXXX: \pm .0005 [0.013]	* PROPRIETARY NOTE * THIS DOCUMENT CONTAINS CONFIDENTIAL AND PROPRIETARY INFORMATION AND ALL DESIGN, MANUFACTURING, REPRODUCTION, USE, PATENT RIGHTS AND SALES RIGHTS ARE EXPRESSLY RESERVED BY SAMTEC, INC. THIS DOCUMENT SHALL NOT BE DISCLOSED, IN WHOLE OR PART, TO ANY UNAUTHORIZED PERSON OR ENTITY NOR REPRODUCED, TRANSFERRED OR INCORPORATED IN ANY OTHER PROJECT IN ANY MANNER WITHOUT THE EXPRESS WRITTEN CONSENT OF SAMTEC, INC.	
		520 PARK EAST BLVD., NEW ALBANY, IN 47150 PHONE: 812-944-6733 FAX: 812-948-5047 e-Mail: info@SAMTEC.com code 55322
		DESCRIPTION: ADAPTER, 1.85MM PLUG TO 1.85MM PLUG DWG. NO. PRFIA-185-P-P-S BY: MATT M 1/19/2022 SHEET 1 OF 1