

DO NOT SCALE FROM THIS PRINT

DESIGNED & DIMENSIONED IN INCHES[MILLIMETERS]

PRFIA-240-P-J-S  
 ADAPTER TYPE  
 -IA: IN-SERIES ADAPTER  
 SERIES  
 -240: 2.4mm  
 END 1 GENDER  
 -P: PLUG  
 ORIENTATION  
 -S: STRAIGHT  
 END 2 GENDER  
 -J: JACK

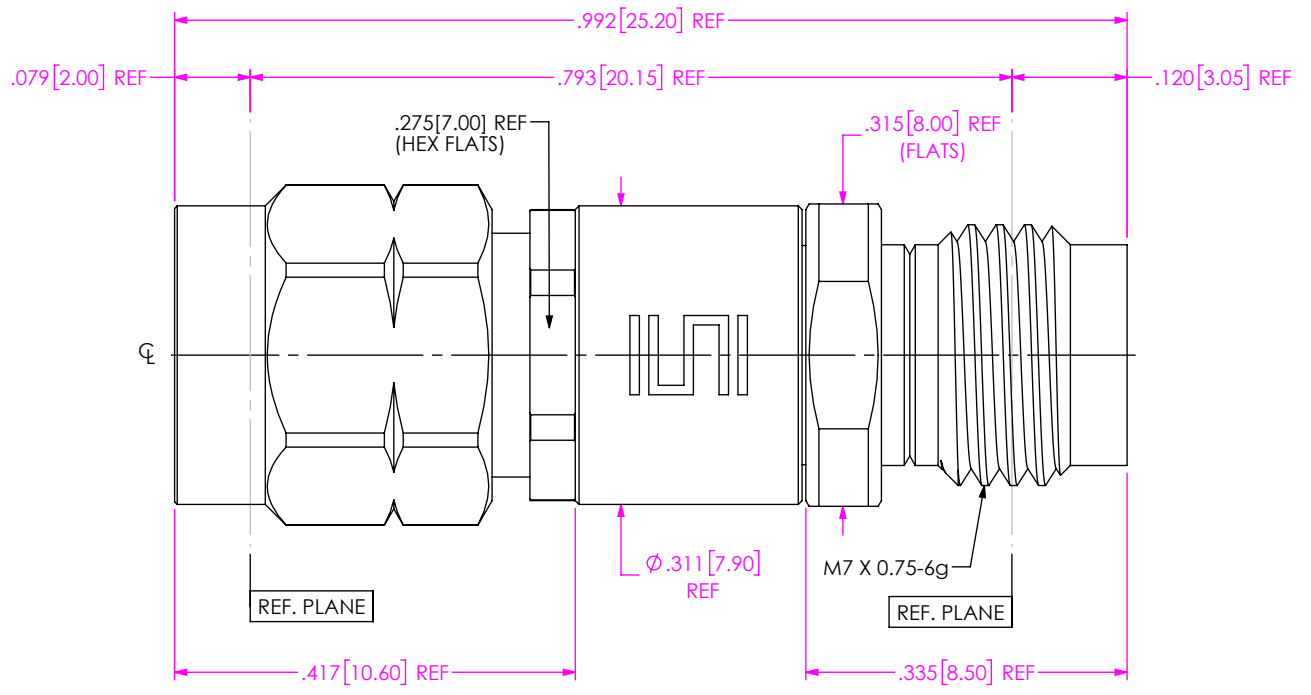
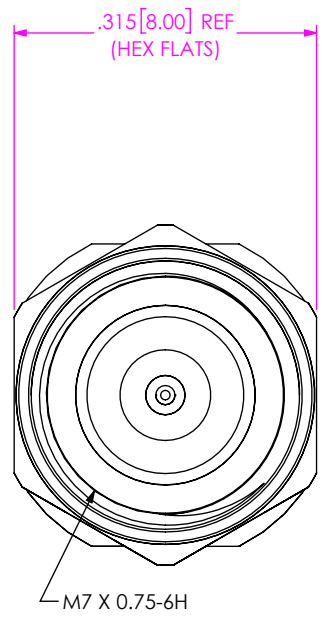

NOTES:

1. MATERIAL:  
 BODY: STAINLESS STEEL  
 CONTACT: BERYLLIUM COPPER  
 BEAD: PEI
2. FINISH:  
 BODY: PASSIVATED  
 CONTACT: GOLD
3. VSWR DC – 50GHz \_\_\_ 1.20:1 MAX
4. INSERTION LOSS .05XSQRT(MAX FREQ) MAX

UNLESS OTHERWISE SPECIFIED, DIMENSIONS ARE IN INCHES. TOLERANCES ARE: DECIMALS                      ANGLES .XX: ±.01 [0.3]                      1° .XXX: ±.005 [0.13] .XXXX: ±.0005 [0.013]	* PROPRIETARY NOTE * THIS DOCUMENT CONTAINS CONFIDENTIAL AND PROPRIETARY INFORMATION AND ALL DESIGN, MANUFACTURING, REPRODUCTION, USE, PATENT RIGHTS AND SALES RIGHTS ARE EXPRESSLY RESERVED BY SAMTEC, INC. THIS DOCUMENT SHALL NOT BE DISCLOSED, IN WHOLE OR PART, TO ANY UNAUTHORIZED PERSON OR ENTITY NOR REPRODUCED, TRANSFERRED OR INCORPORATED IN ANY OTHER PROJECT IN ANY MANNER WITHOUT THE EXPRESS WRITTEN CONSENT OF SAMTEC, INC.	 520 PARK EAST BLVD, NEW ALBANY, IN 47150 PHONE: 812-944-6733    FAX: 812-948-5047 e-Mail info@SAMTEC.com    code 55322
DO NOT SCALE DRAWING	SHEET SCALE: 5:1	DESCRIPTION: ADAPTER, 2.4MM PLUG TO 2.4MM JACK
DWG. NO. PRFIA-240-P-J-S		BY: WILLY Y                      3/7/2022                      SHEET 1 OF 1