

DO NOT SCALE FROM THIS PRINT

QFSS-XXX-XX.XX-X-D-DP-X-XXX

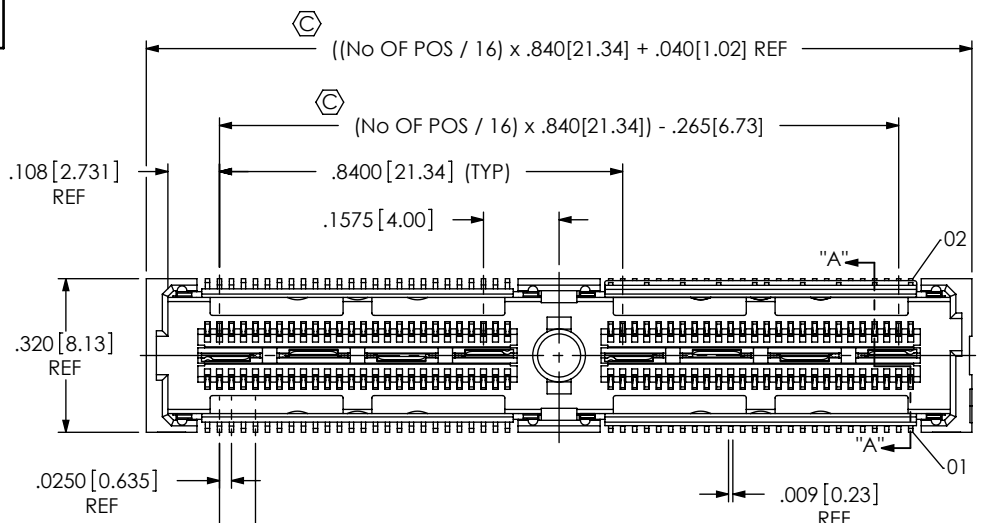

No OF PAIRS
 -016, -032, -048, -064, *-080 (PER ROW)
LEAD STYLE
 -04.25 (SEE NOTE 9)
PLATING SPECIFICATION
 -L: LIGHT GOLD (USE C-181-04.25-L)
 -H: HEAVY GOLD (USE C-181-04.25-H)
 (ALL PLATING STYLES USE SH2-01-L & T-1G20-04.25-L)
ROW SPECIFICATION
 -D: DOUBLE
 SEE FIG. 1 FOR SHIELD BEAM CONFIGURATION

OPTION
 -BM: BLIND MATE SHIELD (USE ASP-126355-02-P-L)
 -GP: GUIDE HOLES (SEE FIG 2, SHEET 2) (NOT AVAILABLE WITH -PXX)
 -PC4: 4 POWER POS PER END (.062" THICK BOARD) (SEE FIG 3, SHEET 3) USE C-79-06-S
 -PC8: 8 POWER POS PER END (.062" THICK BOARD) (SEE FIG 3, SHEET 3) USE C-79-06-S
 -PT4: 4 POWER POS PER END (.093" THICK BOARD) (SEE FIG 3, SHEET 3) USE C-79-09-S
 -PT8: 8 POWER POS PER END (.093" THICK BOARD) (SEE FIG 3, SHEET 3) USE C-79-09-S
 -TR: TAPE & REEL PACKAGING (-016 THRU -048 W/O OPTIONS -GP OR -PXX) (-016 THRU -032 W/ OPTIONS -GP OR -PXX)
-PXX NOT AVAILABLE WITH -GP AND -A]
[PXX AVAILABLE ON POSITIONS -016, -032 & -048 ONLY]

OPTION
 -A: ALIGNMENT PIN (NOT AVAILABLE WITH -PXX)
 -P: PICK AND PLACE PAD (USE PPP-51) (SEE FIG 4, SHT 4)

* = NOT TOOLED

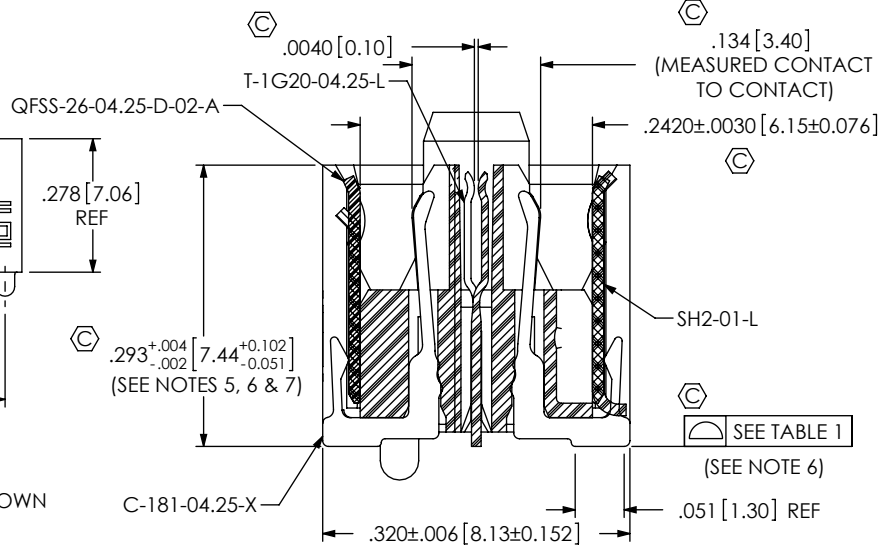
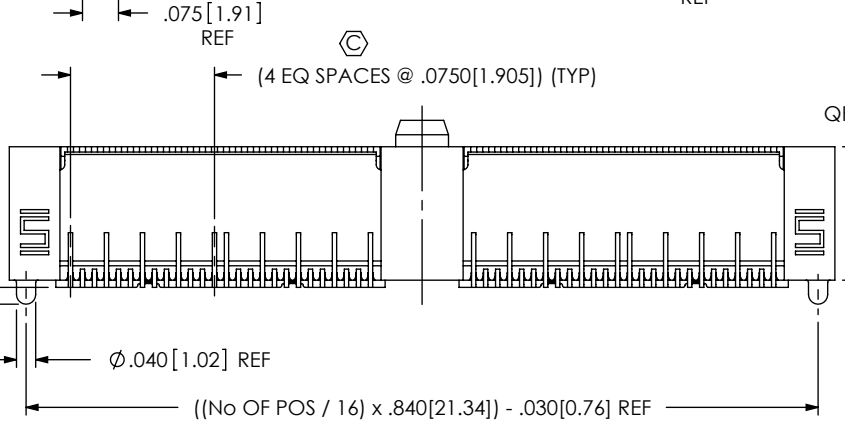

.035[0.89] REF

FIG 1
QFSS-032-04.25-X-D-DP-A SHOWN

SECTION "A"-"A"
SCALE 5:1

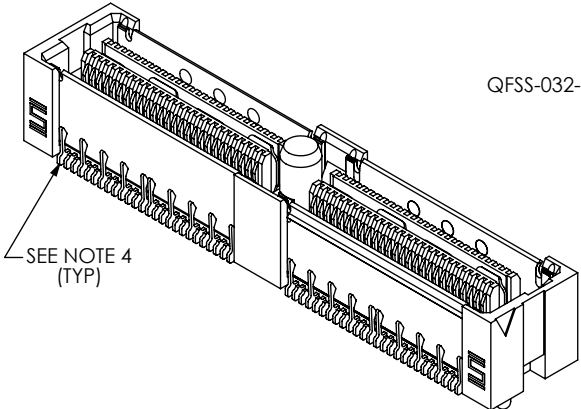

TABLE 1		
No OF POSITIONS	No OF BANKS	COPLANARITY
-016 THRU -048	1 THRU 3	.004[.10]
-064 AND -080	4 AND 5	.006[.15]

- NOTES:
- ⊙ REPRESENTS A CRITICAL DIMENSION.
 - MAXIMUM BURR ALLOWANCE: .0015 [0.038]
 - MINIMUM PUSHOUT FORCE: SIGNAL: .5 LB, SHIELD/GROUND: 1 LB, POWER: .5 LB.
 - DO NOT SHEAR CONTACTS SHOWN.
 - MAXIMUM VARIANCE: .002 [0.05].
 - DIMENSION APPLIES TO CONTACTS & GROUND PLANE.
 - GROUND PLANE PRESS HEIGHT MUST BE .003 [0.08] LESS THAN THE MAXIMUM HEIGHT OR .001 [0.03] GREATER THAN THE MINIMUM HEIGHT OF THE TERMINAL.
 - PARTS TO BE PACKAGED IN TRAYS AS STANDARD.
 - LEADSTYLE -01 MAY BE SUBSTITUTED IN PART CALLOUT FOR -04.25 FOR EXISTING CUSTOMERS ONLY.

PATENT NUMBERS
6739884/ 7165994
7121849

UNLESS OTHERWISE SPECIFIED, DIMENSIONS ARE IN INCHES. TOLERANCES ARE:
 DECIMALS ANGLES
 .XX: ±.01 [.3] 2°
 .XXX: ±.005 [.13]
 .XXXX: ±.0020 [.051]

PROPRIETARY NOTE
 THIS DOCUMENT CONTAINS INFORMATION CONFIDENTIAL AND PROPRIETARY TO SAMTEC, INC. AND SHALL NOT BE REPRODUCED OR TRANSFERRED TO OTHER DOCUMENTS OR DISCLOSED TO OTHERS OR USED FOR ANY PURPOSE OTHER THAN THAT WHICH IT WAS OBTAINED WITHOUT THE EXPRESSED WRITTEN CONSENT OF SAMTEC, INC.



520 PARK EAST BLVD, NEW ALBANY, IN 47150
 PHONE: 812-944-6733 FAX: 812-948-5047
 e-Mail: info@SAMTEC.com code 55322

MATERIAL: DO NOT SCALE DRAWING SHEET SCALE: 2.5:1
 INSULATOR: VECTRA E130, COLOR: BLACK
 TERMINAL, GROUND PLANE, & SHIELD: PHOS BRONZE:

DESCRIPTION:
.635mm DIFFERENTIAL PAIRS SHIELDED TERMINAL STRIP

DWG. NO.
QFSS-XXX-XX.XX-X-D-DP-X-XXX

BY: BRATCHER 08/26/2003 SHEET 1 OF 4

REVISION Y

IN-PROCESS 1

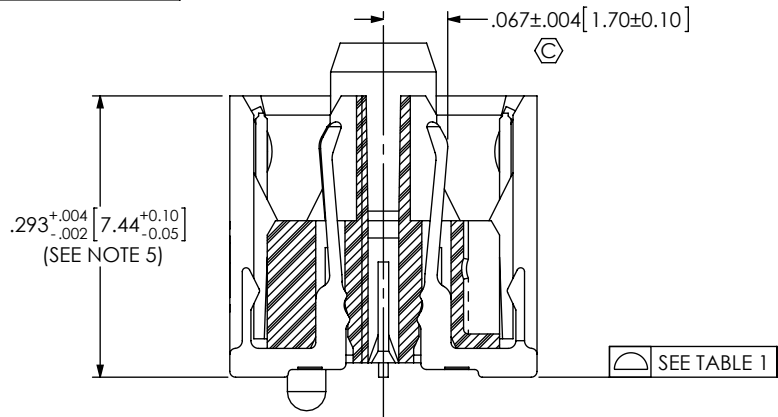

CONTACT DETAILS

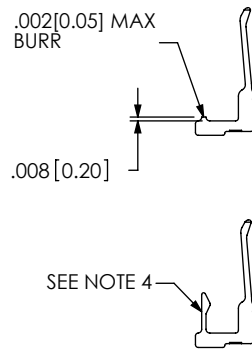

TABLE 2		
ASSEMBLY	"A"	"B"
QFSS-016-04.25-X-D-DP-A-GP	1.050[26.67]	1.330[33.78]
QFSS-032-04.25-X-D-DP-A-GP	1.890[48.00]	2.170[55.12]
QFSS-048-04.25-X-D-DP-A-GP	2.730[69.34]	3.010[76.45]
QFSS-064-04.25-X-D-DP-A-GP	3.570[90.68]	3.850[97.79]
QFSS-080-04.25-X-D-DP-A-GP	4.410[112.01]	4.690[119.13]

IN-PROCESS 2

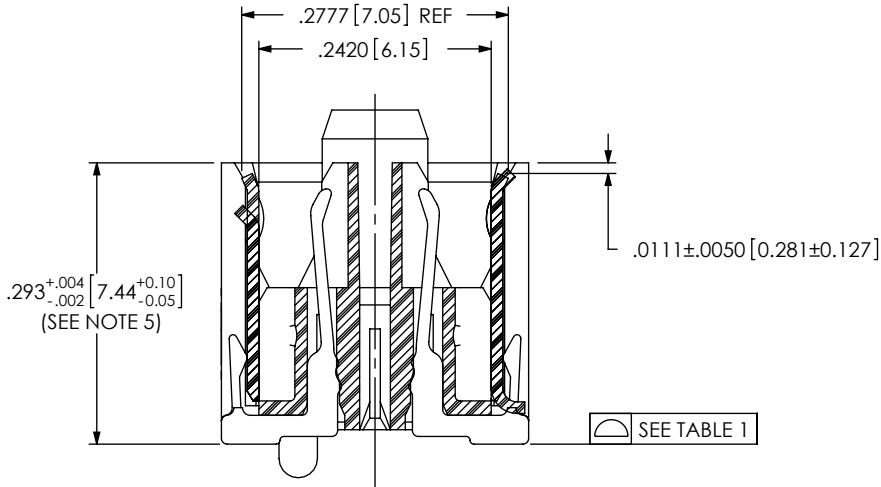
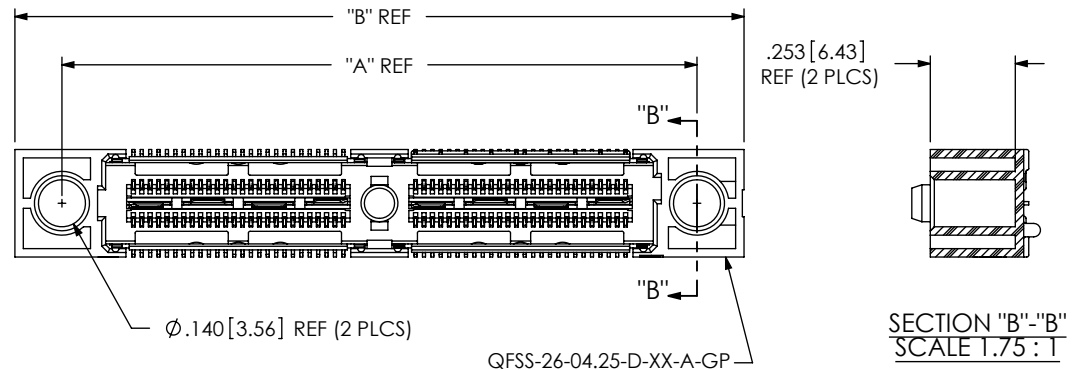

FIG 2
-GP: GUIDE HOLE OPTION
(QFSS-032-04.25-X-D-DP-A-GP SHOWN)
(NOT AVAILABLE WITH -PXX OPTIONS)



PROPRIETARY NOTE

THIS DOCUMENT CONTAINS INFORMATION CONFIDENTIAL AND PROPRIETARY TO SAMTEC, INC. AND SHALL NOT BE REPRODUCED OR TRANSFERRED TO OTHER DOCUMENTS OR DISCLOSED TO OTHERS OR USED FOR ANY PURPOSE OTHER THAN THAT WHICH IT WAS OBTAINED WITHOUT THE EXPRESSED WRITTEN CONSENT OF SAMTEC, INC.

DO NOT SCALE DRAWING

SHEET SCALE: 2.5:1

samtec

520 PARK EAST BLVD, NEW ALBANY, IN 47150
PHONE: 812-944-6733 FAX: 812-948-5047
e-Mail: info@SAMTEC.com code 55322

DESCRIPTION:
.635mm DIFFERENTIAL PAIRS SHIELDED TERMINAL STRIP

DWG. NO.
QFSS-XXX-XX.XX-X-D-DP-X-XXX

BY: BRATCHER 08/26/2003 SHEET 2 OF 4

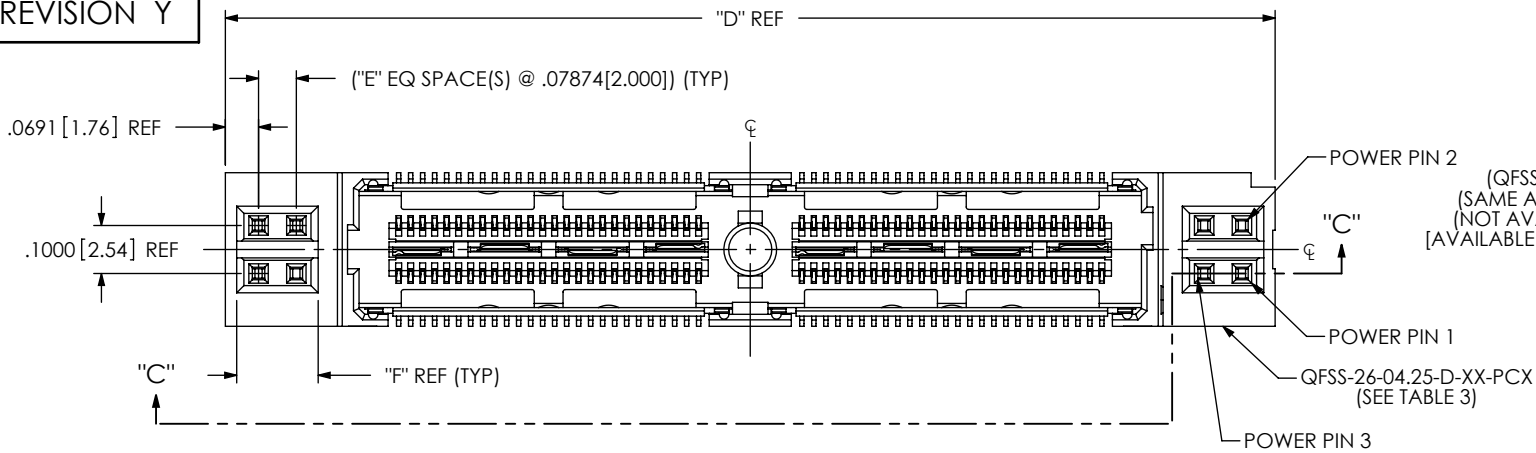
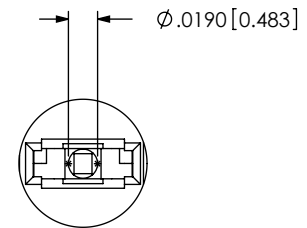
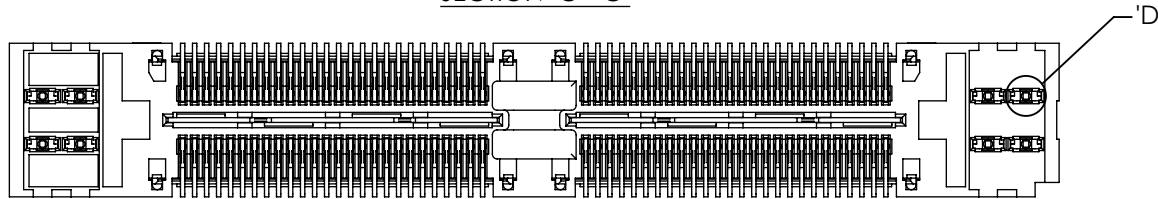
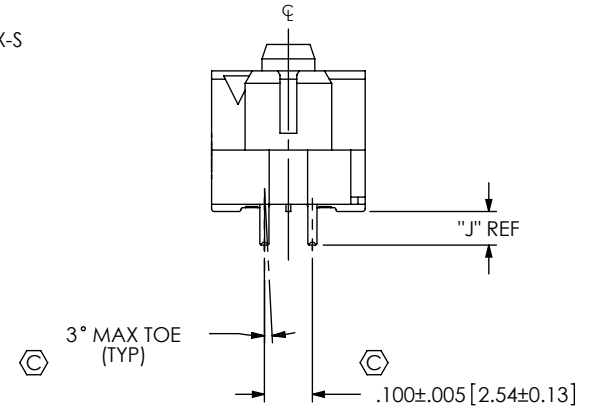
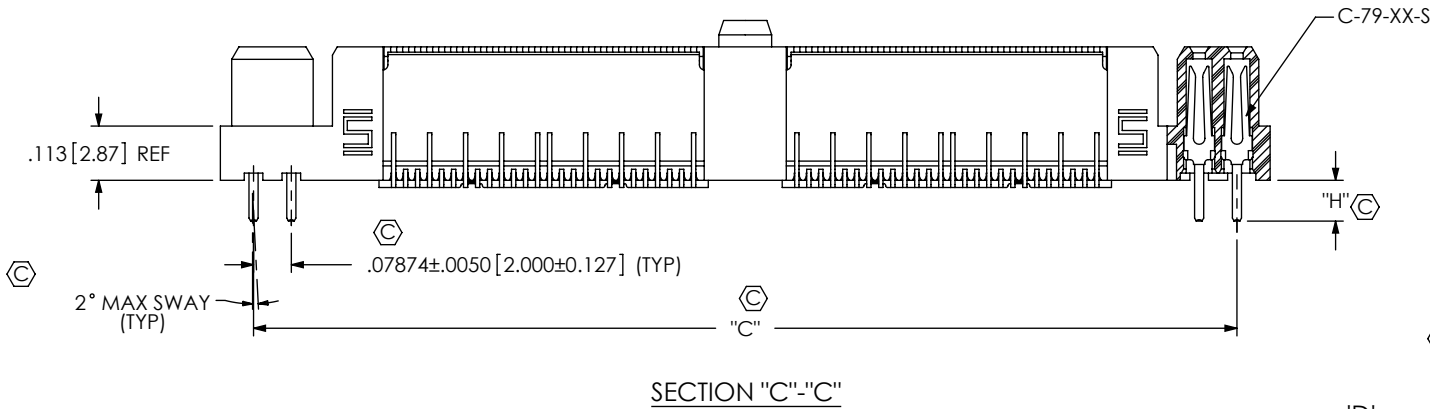

FIG 3

POWER COMBO OPTIONS
 (QFSS-032-04.25-X-D-DP-PC4 SHOWN)
 (SAME AS FIG 1, UNLESS OTHERWISE STATED)
 (NOT AVAILABLE WITH -GP AND -A OPTIONS)
 [AVAILABLE ON -016, -032 & -048 POSITIONS ONLY]



DETAIL 'D'
 SCALE 8 : 1

POWER OPTION	CONTACT	"H"	"J"
PC4/PC8	C-79-06-S	.085 [2.16]	.070 [1.78]
PT4/PT8	C-79-09-S	.125 [3.18]	.110 [2.79]

ASSEMBLY	QFSS-26-04.25-D-XX-PCX	"C"	"D"	"E"	"F"
QFSS-016-04.25-X-D-DP-X-PX4	QFSS-26-04.25-D-01-PC4	1.209[30.70]	1.347[34.21]	1	.170[4.31]
QFSS-016-04.25-X-D-DP-X-PX8	QFSS-26-04.25-D-01-PC8	1.524[38.70]	1.662[42.21]	3	.327[8.31]
QFSS-032-04.25-X-D-DP-X-PX4	QFSS-26-04.25-D-02-PC4	2.049[52.04]	2.187[55.55]	1	.170[4.31]
QFSS-032-04.25-X-D-DP-X-PX8	QFSS-26-04.25-D-02-PC8	2.364[60.04]	2.502[63.55]	3	.327[8.31]
QFSS-048-04.25-X-D-DP-X-PX4	QFSS-26-04.25-D-03-PC4	2.889[73.37]	3.027[76.89]	1	.170[4.31]
QFSS-048-04.25-X-D-DP-X-PX8	QFSS-26-04.25-D-03-PC8	3.204[81.37]	3.342[84.89]	3	.327[8.31]

PROPRIETARY NOTE
 THIS DOCUMENT CONTAINS INFORMATION
 CONFIDENTIAL AND PROPRIETARY TO
 SAMTEC, INC. AND SHALL NOT BE REPRODUCED
 OR TRANSFERRED TO OTHER DOCUMENTS OR
 DISCLOSED TO OTHERS OR USED FOR ANY
 PURPOSE OTHER THAN THAT WHICH IT WAS
 OBTAINED WITHOUT THE EXPRESSED WRITTEN
 CONSENT OF SAMTEC, INC.

DO NOT SCALE DRAWING
 SHEET SCALE: 2:5:1



520 PARK EAST BLVD, NEW ALBANY, IN 47150
 PHONE: 812-944-6733 FAX: 812-948-5047
 e-Mail: info@SAMTEC.com code 55322

DESCRIPTION:
 .635mm DIFFERENTIAL PAIRS SHIELDED TERMINAL STRIP

DWG. NO.
QFSS-XXX-XX.XX-X-D-DP-X-XXX

BY: BRATCHER 08/26/2003 SHEET 3 OF 4

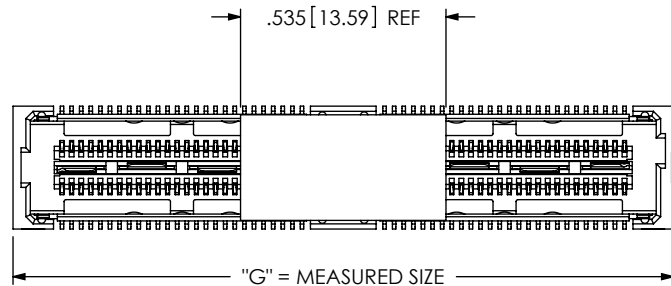

FIG 4

-P: PICK AND PLACE PAD OPTION
(QFSS-032-04.25-X-D-DP-P SHOWN)
(SAME AS FIG 1, UNLESS OTHERWISE STATED)
[USE PPP-51]

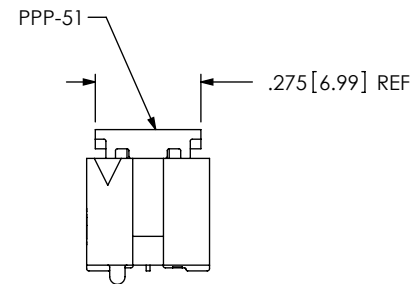
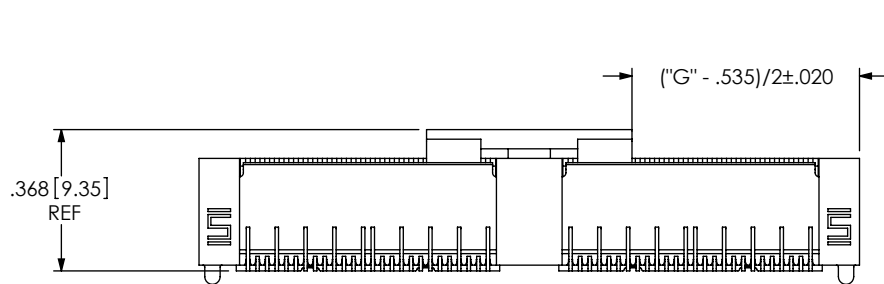
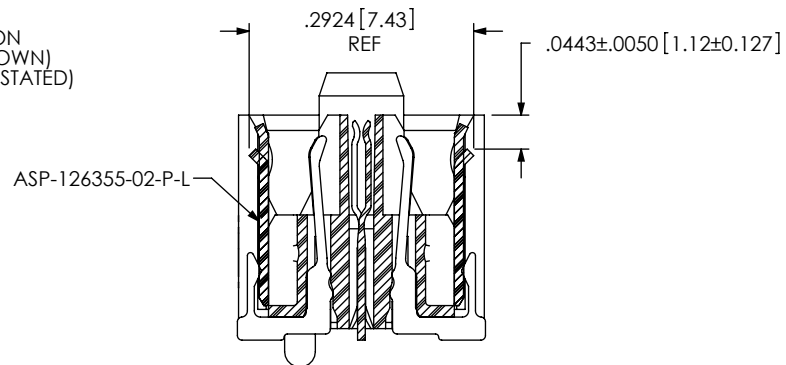
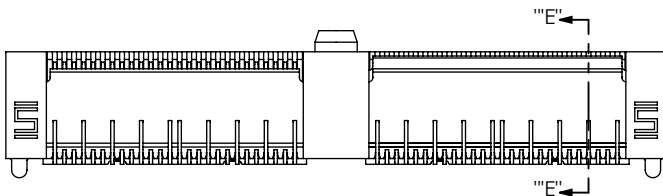

FIG 5

-BM: BLIND MATE SHIELD OPTION
(QFSS-032-04.25-X-D-DP-A-BM SHOWN)
(SAME AS FIG 1, UNLESS OTHERWISE STATED)



SECTION "E"-"E"
SCALE 4 : 1

PROPRIETARY NOTE

THIS DOCUMENT CONTAINS INFORMATION CONFIDENTIAL AND PROPRIETARY TO SAMTEC, INC. AND SHALL NOT BE REPRODUCED OR TRANSFERRED TO OTHER DOCUMENTS OR DISCLOSED TO OTHERS OR USED FOR ANY PURPOSE OTHER THAN THAT WHICH IT WAS OBTAINED WITHOUT THE EXPRESSED WRITTEN CONSENT OF SAMTEC, INC.

DO NOT SCALE DRAWING

SHEET SCALE: 2.5:1



520 PARK EAST BLVD, NEW ALBANY, IN 47150
PHONE: 812-944-6733 FAX: 812-948-5047
e-Mail: info@SAMTEC.com code 55322

DESCRIPTION:
.635mm DIFFERENTIAL PAIRS SHIELDED TERMINAL STRIP
DWG. NO.

QFSS-XXX-XX.XX-X-D-DP-X-XXX

BY: BRATCHER 08/26/2003 SHEET 4 OF 4