

DO NOT
SCALE FROM
THIS PRINT

No OF POSITIONS
 02,-04, -05, -07, -10, -15, -20, -25, & -30 (PER ROW) AVAILABLE AS STANDARD;
 OTHER SIZES BETWEEN -05 THRU -50 AVAILABLE AS ASO

LEAD STYLE
 -01: THROUGH HOLE (USE C-56-01-X)
 -02: SURFACE MOUNT (USE C-56-05-X) (31-50 POSITION, NOT RELEASED)

PLATING SPECIFICATION
 -F: 3μ" SELECTIVE GOLD IN CONTACT AREA, MATTE TIN ON TAIL. (USE C-56-XX-F)
 -S: 30μ" SELECTIVE GOLD IN CONTACT AREA, MATTE TIN ON TAIL. (USE C-56-XX-S)
 -L: 10μ" SELECTIVE GOLD IN CONTACT AREA, MATTE TIN ON TAIL. (USE C-56-XX-L)

PACKAGING
 BLANK: TUBES
 -TR: TAPE & REEL (-02 LEAD ONLY)
 -FR: FULL REEL QTY TAPE & REEL (SEE NOTES 6 & 7)

PAD OPTION
 -K: POLYIMIDE FILM PAD (USE K-DOT-.217-.313-.005) (-02 LEAD ONLY)

OPTION
 -LC: LOCKING CLIP (-02 LEAD STYLE ONLY) (USE LC-07-TM)
 -DS: DUAL SCREW DOWN FOR .062 BOARD (SEE FIG 4 & 5 SHT 3) (NOT AVAILABLE WITH -LC OPTION) (ONLY AVAILABLE 2-30 POSITIONS) (USES S2M-XX-D-DS, CPS-RR-XX-XX-X, ACCRT-01 AND WT-27-02-T ALWAYS FILLED)

ROW SPECIFICATION
 -D: DOUBLE ROW

(**= MUST CHOOSE -02 LEAD AND -XR PACKAGING)

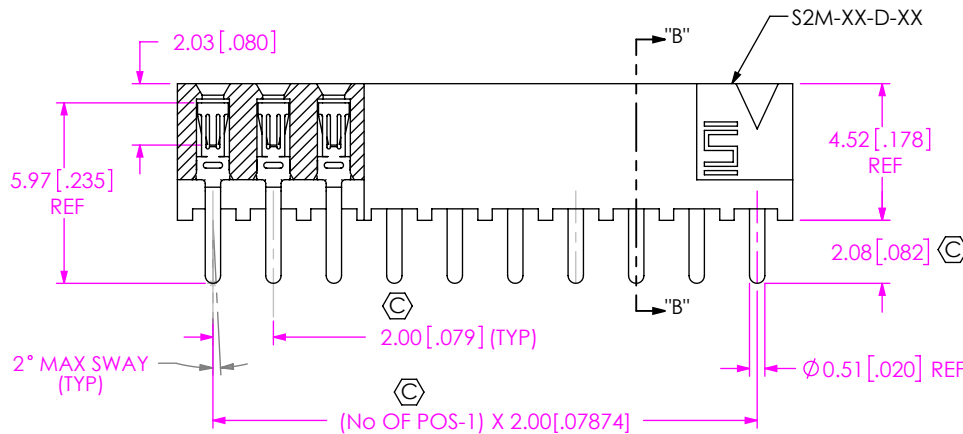
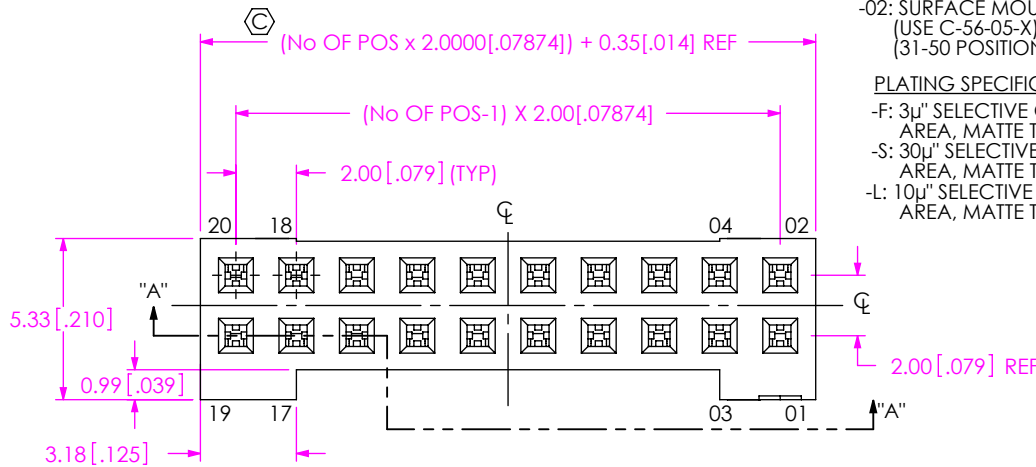

SECTION "A"-"A"

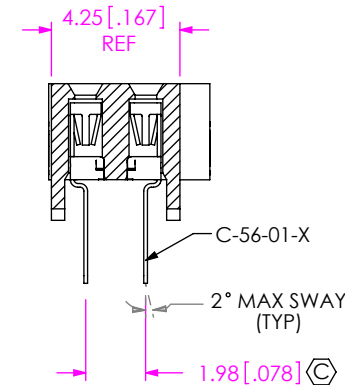

SECTION "B"-"B"

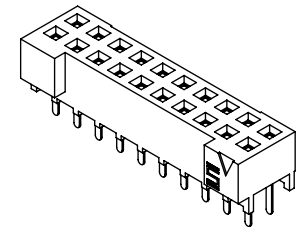

FIG 1
S2M-110-01-XX-D SHOWN

NOTES:

- ⊕ REPRESENTS A CRITICAL DIMENSION.
- MINIMUM CONTACT RETENTION FORCE: 4.45 N[1.000 LB.].
- "-LC" OPTION FOR A -02 POSITION WILL HAVE ONLY ONE LOCKING CLIP (LC-07-X).
- MINIMUM RETENTION FOR LOCKING CLIP, WELD TAB & ACCRT: 3.3 N [.75 LB.].
- MAXIMUM ALLOWABLE VARIATION BETWEEN ROWS 0.13 [.005].
- ORDERS WILL BE PACKAGED ACCORDING TO THE SAMTEC PACKAGING EFFICIENCY STANDARDS FOUND ON WWW.SAMTEC.COM
- ATTACH LABEL -4x2 TO EACH REEL

UNLESS OTHERWISE SPECIFIED, DIMENSIONS ARE IN MILLIMETERS.
 TOLERANCES ARE:
 DECIMALS ANGLES
 X.X: ±0.3[.01] 2°
 X.XX: ±0.13[.005]
 X.XXX: ±0.051[.0020]

PROPRIETARY NOTE
 THIS DOCUMENT CONTAINS CONFIDENTIAL AND PROPRIETARY INFORMATION AND ALL DESIGN, MANUFACTURING, REPRODUCTION, USE, PATENT RIGHTS AND SALES RIGHTS ARE EXPRESSLY RESERVED BY SAMTEC, INC. THIS DOCUMENT SHALL NOT BE DISCLOSED, IN WHOLE OR PART, TO ANY UNAUTHORIZED PERSON OR ENTITY NOR REPRODUCED, TRANSFERRED OR INCORPORATED IN ANY OTHER PROJECT IN ANY MANNER WITHOUT THE EXPRESS WRITTEN CONSENT OF SAMTEC, INC.



520 PARK EAST BLVD, NEW ALBANY, IN 47150
 PHONE: 812-944-6733 FAX: 812-948-5047
 e-Mail: info@SAMTEC.com code 55322

MATERIAL: DO NOT SCALE DRAWING SHEET SCALE: 4:1
 LCP COLOR: BLACK
 CONTACT: BeCu

DESCRIPTION: 2mm DOUBLE ROW SOCKET STRIP

DWG. NO.: S2M-1XX-XX-X-D-XX-X-XX

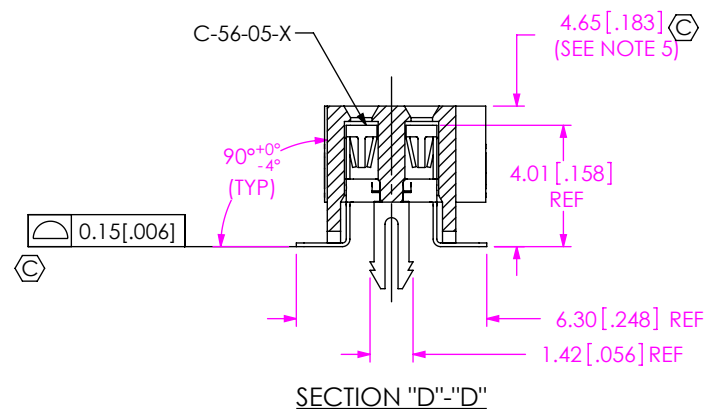
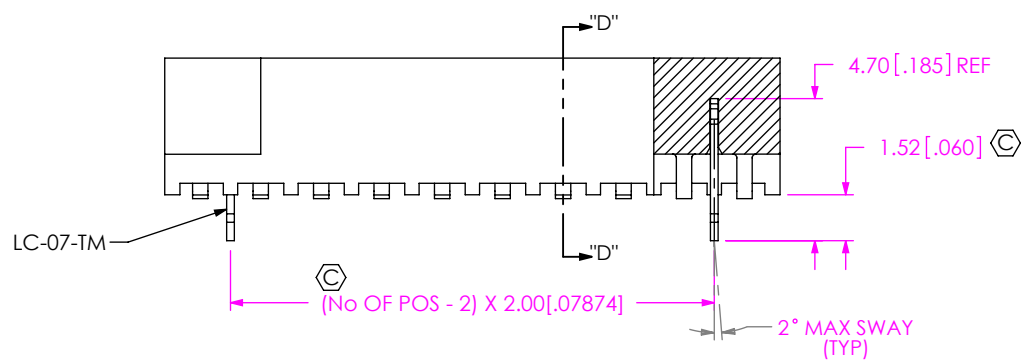
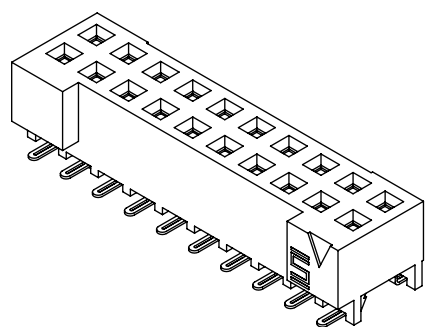
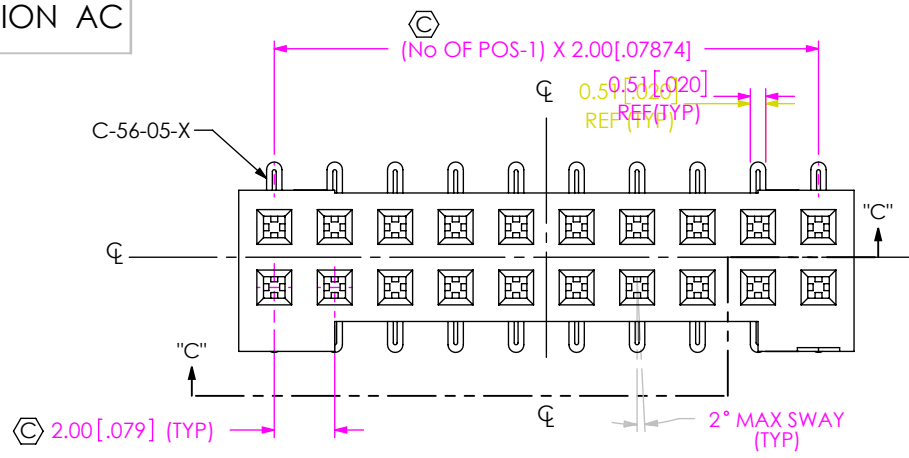

SECTION "C"-"C"

FIG 2
S2M-110-02-X-D-LC SHOWN
(SAME AS FIG 1, EXCEPT AS SHOWN)

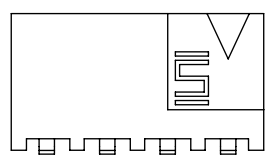
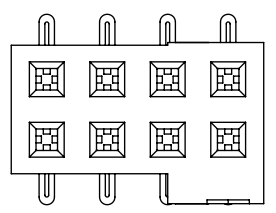

FIG 6
S2M-104-02-X-D SHOWN
(SAME AS FIG 1, EXCEPT AS SHOWN)

F:\DWG\MISC\MKTG\S2M-1XX-XX-X-D-XX-X-XX-MKT.SLDDRW

PROPRIETARY NOTE
THIS DOCUMENT CONTAINS CONFIDENTIAL AND PROPRIETARY INFORMATION AND ALL DESIGN, MANUFACTURING, REPRODUCTION, USE, PATENT RIGHTS AND SALES RIGHTS ARE EXPRESSLY RESERVED BY SAMTEC, INC. THIS DOCUMENT SHALL NOT BE DISCLOSED, IN WHOLE OR PART, TO ANY UNAUTHORIZED PERSON OR ENTITY NOR REPRODUCED, TRANSFERRED OR INCORPORATED IN ANY OTHER PROJECT IN ANY MANNER WITHOUT THE EXPRESS WRITTEN CONSENT OF SAMTEC, INC.



520 PARK EAST BLVD, NEW ALBANY, IN 47150
PHONE: 812-944-6733 FAX: 812-948-5047
e-Mail info@SAMTEC.com code 55322

DO NOT SCALE DRAWING

SHEET SCALE: 4:1

DESCRIPTION:
2mm DOUBLE ROW SOCKET STRIP

DWG. NO.
S2M-1XX-XX-X-D-XX-X-XX

BY: T NEWTON 09/16/2010 SHEET 2 OF 4

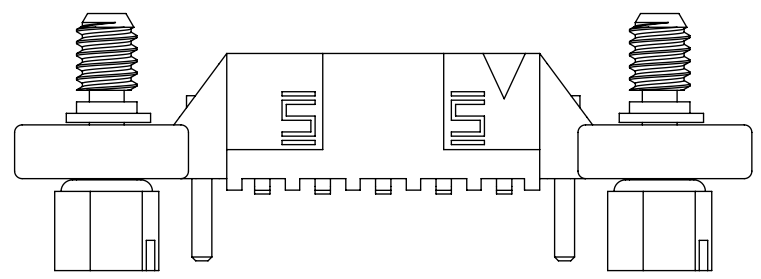
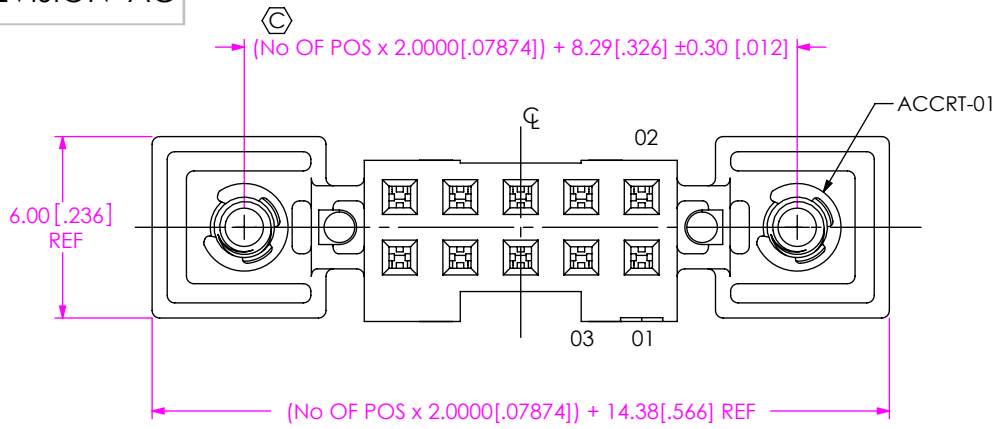

FIG 5
S2M-105-02-X-D-DS SHOWN
(SAME AS FIG 4, EXCEPT AS SHOWN)

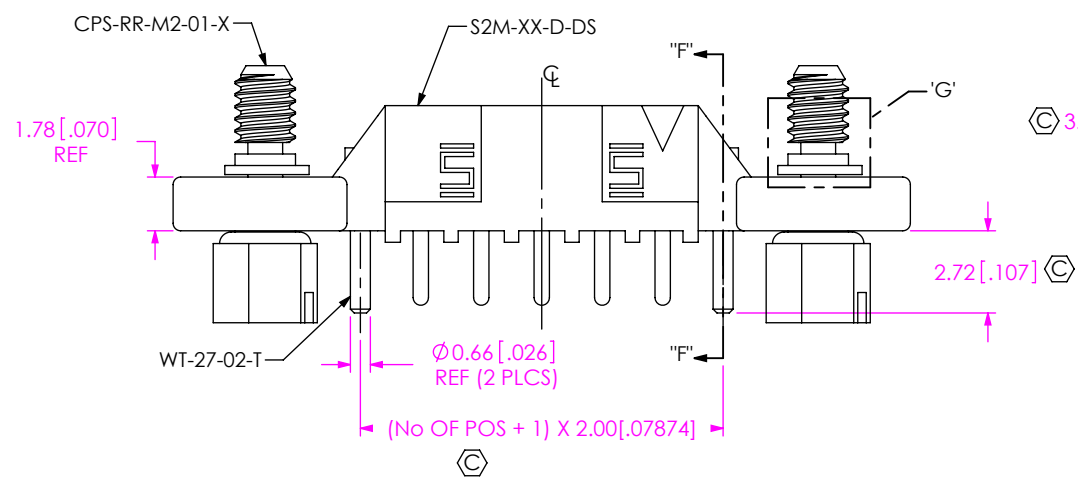
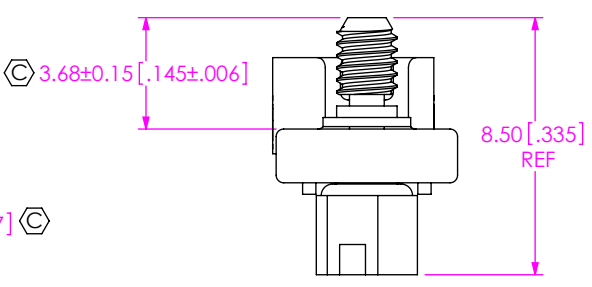
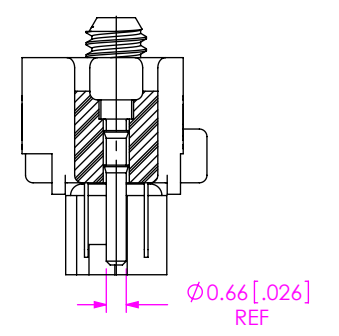

FIG 4
S2M-105-01-X-D-DS SHOWN
(SAME AS FIG 1, EXCEPT AS SHOWN)



DETAIL 'G'
SCALE 8 : 1



SECTION "F"-"F"

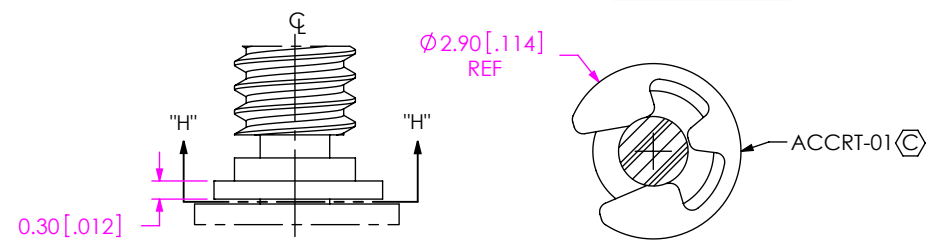

SECTION "H"-"H"
SCALE 8 : 1

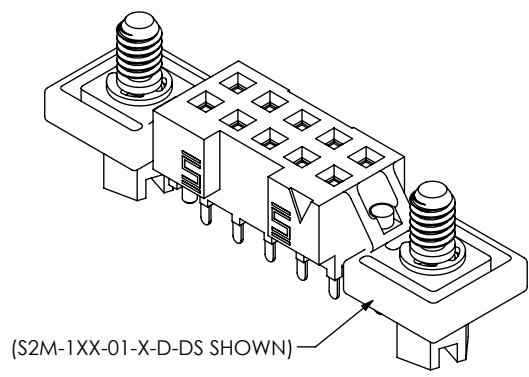

(S2M-1XX-01-X-D-DS SHOWN)

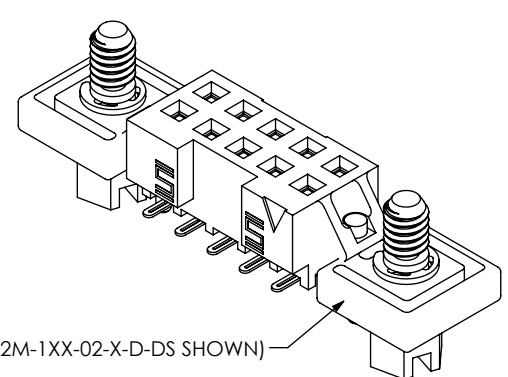

(S2M-1XX-02-X-D-DS SHOWN)

PROPRIETARY NOTE
THIS DOCUMENT CONTAINS CONFIDENTIAL AND PROPRIETARY INFORMATION AND ALL DESIGN, MANUFACTURING, REPRODUCTION, USE, PATENT RIGHTS AND SALES RIGHTS ARE EXPRESSLY RESERVED BY SAMTEC, INC. THIS DOCUMENT SHALL NOT BE DISCLOSED, IN WHOLE OR PART, TO ANY UNAUTHORIZED PERSON OR ENTITY NOR REPRODUCED, TRANSFERRED OR INCORPORATED IN ANY OTHER PROJECT IN ANY MANNER WITHOUT THE EXPRESS WRITTEN CONSENT OF SAMTEC, INC.

DO NOT SCALE DRAWING
SHEET SCALE: 4:1



520 PARK EAST BLVD, NEW ALBANY, IN 47150
PHONE: 812-944-6733 FAX: 812-948-5047
e-Mail info@SAMTEC.com code 55322

DESCRIPTION:
2mm DOUBLE ROW SOCKET STRIP

DWG. NO.
S2M-1XX-XX-X-D-XX-X-XX

BY: T NEWTON 09/16/2010 SHEET 3 OF 4

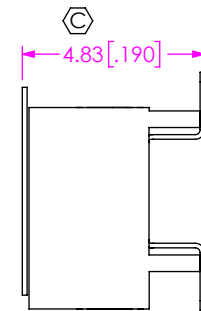
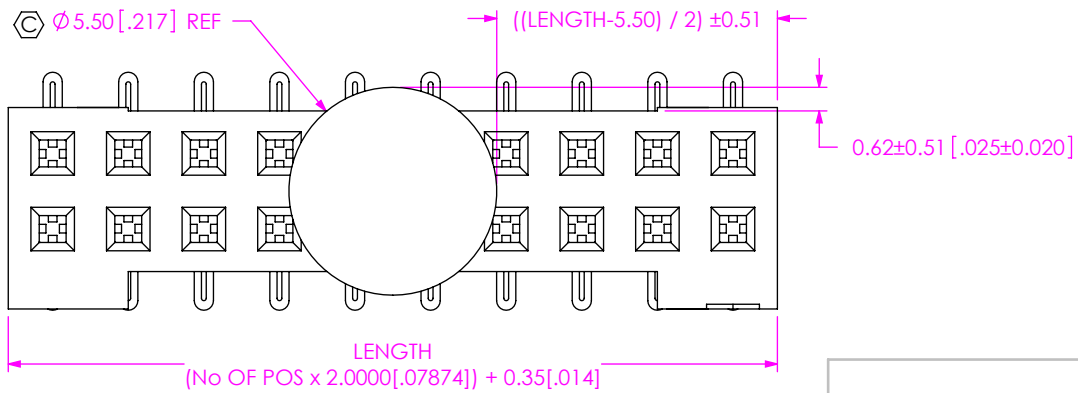
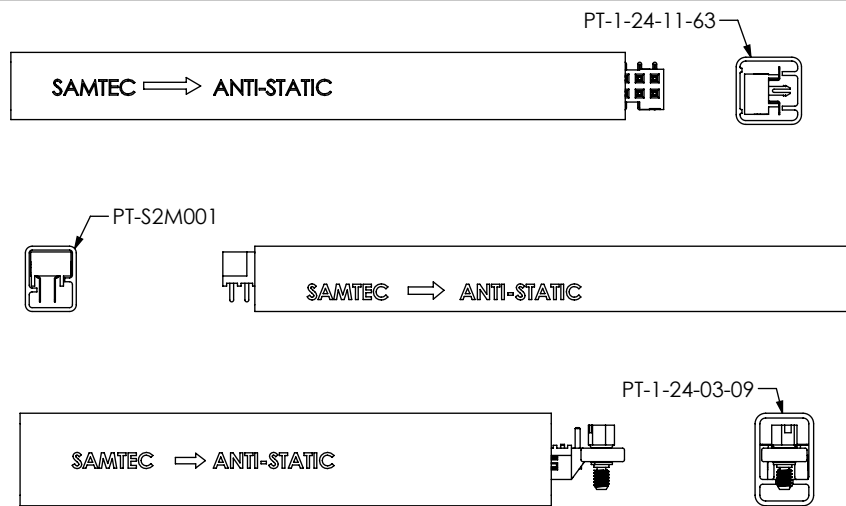
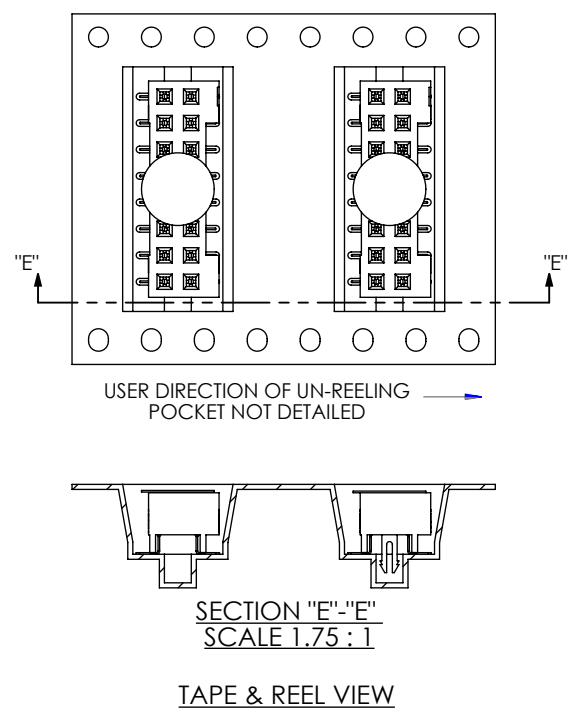

FIG 3
S2M-110-02-X-D-K SHOWN
(SAME AS FIG 2, EXCEPT AS SHOWN)



TUBE TABLE		
LEAD STYLE	TUBE	PLUG
-01	PT-S2M001	TP-09
-02-LC	PT-1-24-11-63	TP-24
-XX-DS	PT-1-24-03-09	TP-03
-02	PT-1-24-03-09	TP-03
-02-K	PT-1-24-03-09	TP-03

PACKAGING VIEW

F:\DWG\MISC\MKTG\S2M-1XX-XX-X-D-XX-X-MKT.SLDDRW

PROPRIETARY NOTE
THIS DOCUMENT CONTAINS CONFIDENTIAL AND PROPRIETARY INFORMATION AND ALL DESIGN, MANUFACTURING, REPRODUCTION, USE, PATENT RIGHTS AND SALES RIGHTS ARE EXPRESSLY RESERVED BY SAMTEC, INC. THIS DOCUMENT SHALL NOT BE DISCLOSED, IN WHOLE OR PART, TO ANY UNAUTHORIZED PERSON OR ENTITY NOR REPRODUCED, TRANSFERRED OR INCORPORATED IN ANY OTHER PROJECT IN ANY MANNER WITHOUT THE EXPRESS WRITTEN CONSENT OF SAMTEC, INC.



520 PARK EAST BLVD, NEW ALBANY, IN 47150
PHONE: 812-944-6733 FAX: 812-948-5047
e-Mail info@SAMTEC.com code 55322

DO NOT SCALE DRAWING
SHEET SCALE: 4:1

DESCRIPTION:
2mm DOUBLE ROW SOCKET STRIP

DWG. NO.
S2M-1XX-XX-X-D-XX-X-XX

BY: T NEWTON 09/16/2010 SHEET 4 OF 4