

DO NOT SCALE FROM THIS PRINT

SEAR-XX-XX.X-XX-XXXX

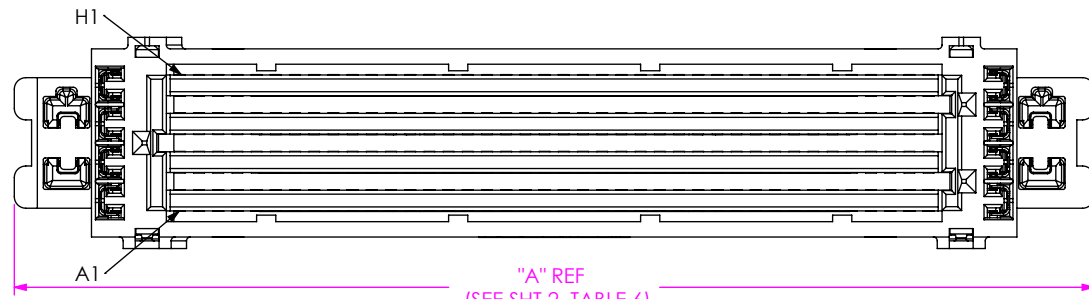

No OF POSITIONS
 *-10, *.15, **-.20, *.30, -40, -50 (PER ROW) (SEE NOTE 7)
LEAD STYLE
 -10.0: 10mm
 -20.0: 20mm
 -30.0: 30mm
 ***-31.0: 31mm

OHMS
 *.050: 50 OHMS SINGLE-ENDED ONLY (GSGSGSG...)
 -085: 85 OHMS DIFFERENTIAL PAIR ONLY (GSSGSSGSSG...)
 **-.085Q: 85 OHMS LOW CROSSTALK FOR QPI APPLICATIONS
 #-100: 100 OHMS DIFFERENTIAL PAIR ONLY (GSSGSSGSSG...)

ROW
 *.04: 4 ROW
 -06: 6 ROW
 -08: 8 ROW
 -10: 10 ROW

(* = NOT TOOLED)
 (** = TOOLED ONLY IN -20 & -40 POS, -31.0mm LEADSTYLE)
 (***) = TOOLED ONLY FOR -085 & -085Q OHM OPTION)
 (# = ONLY TOOLED IN -40 POS, -20.0 LEADSTYLE, -10 ROW)

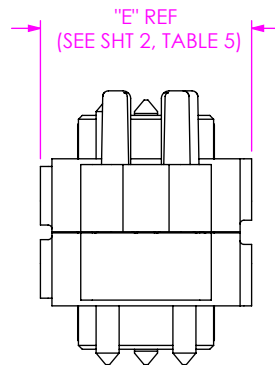
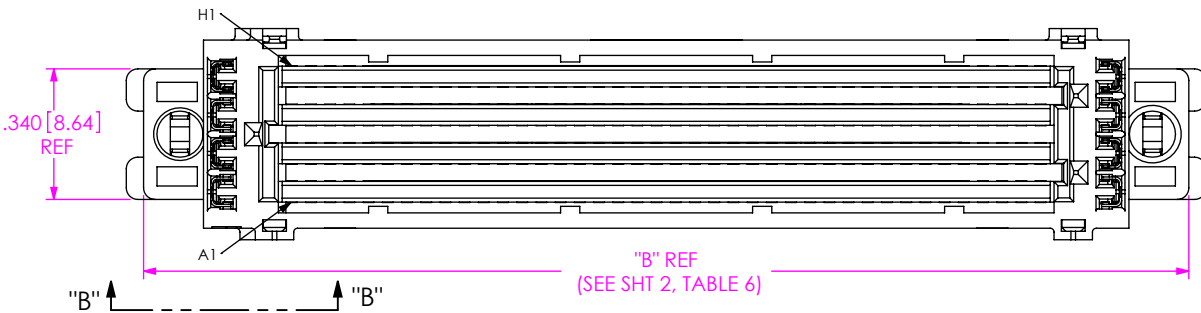
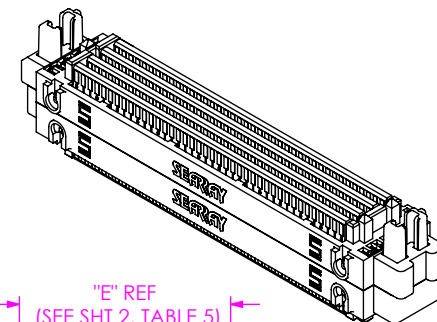
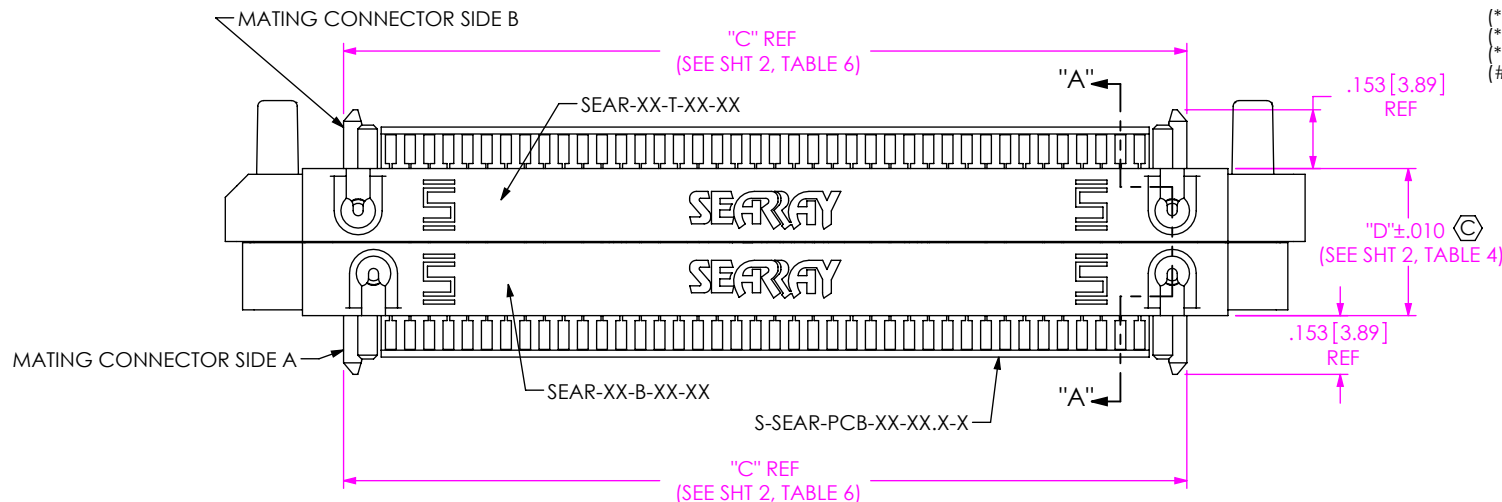

NOTES:

1. REPRESENTS A CRITICAL DIMENSION.
2. ALIGN WITH MATING CONNECTOR SIDE A SEAF PIN 1 INDICATOR.
3. PCB CENTERING CLIP RETENTION TO BE TBD.
4. PCB PAD PLATED WITH .000030 INCHES GOLD WITH A HARDNESS OF 130-200 KNOOP PER ASTM B 488 TYPE 2, GRADE C.
5. DOWEL PIN RETENTION AFTER HEAT STAKE TO BE 1.0LBS[4.44N] MIN.
6. ASSEMBLIES TO BE PACKAGED IN TUBES.
7. -20 POSITION ONLY AVAILABLE IN 10 ROW.

FIG 1 SEAR-40-10.0-08-085 SHOWN

TABLE 1 STACK HEIGHT					
CONNECTOR SIDE A SEAF LEAD STYLE	CONNECTOR SIDE B SEAF LEAD STYLE	SEAR LEAD STYLE			
		-10.0	-20.0	-30.0	-31.0
-05.0	-05.0	20mm	30mm	40mm	41mm

TABLE 2			
SEAR ASSEMBLY (LEAD STYLE)	TOP BODY CALLOUT	BOTTOM BODY CALLOUT	PCB P/N (SEE TABLE 3 FOR ALTERNATE BOM PCB's)
SEAR-XX-10.0-XX-XXX	SEAR-XX-T-01-XX	SEAR-XX-B-01-XX	S-SEAR-PCB-XX-10.0-X
SEAR-XX-20.0-XX-XXX	SEAR-XX-T-02-XX	SEAR-XX-B-01-XX	S-SEAR-PCB-XX-20.0-X
SEAR-XX-30.0-XX-XXX	SEAR-XX-T-02-XX	SEAR-XX-B-02-XX	S-SEAR-PCB-XX-30.0-X
SEAR-XX-31.0-XX-085Q	SEAR-XX-T-02-XX	SEAR-XX-B-02-XX	S-SEAR-PCB-XX-31.0-X

UNLESS OTHERWISE SPECIFIED, DIMENSIONS ARE IN INCHES.
 TOLERANCES ARE:
 DECIMALS ANGLES
 .XX: ±.01 [0.3] 2°
 .XXX: ±.003 [0.08]
 .XXXX: ±.0020 [0.051]

PROPRIETARY NOTE
 THIS DOCUMENT CONTAINS CONFIDENTIAL AND PROPRIETARY INFORMATION AND ALL DESIGN, MANUFACTURING, REPRODUCTION, USE, PATENT RIGHTS AND SALES RIGHTS ARE EXPRESSLY RESERVED BY SAMTEC, INC. THIS DOCUMENT SHALL NOT BE DISCLOSED, IN WHOLE OR PART, TO ANY UNAUTHORIZED PERSON OR ENTITY NOR REPRODUCED, TRANSFERRED OR INCORPORATED IN ANY OTHER PROJECT IN ANY MANNER WITHOUT THE EXPRESS WRITTEN CONSENT OF SAMTEC, INC.



520 PARK EAST BLVD, NEW ALBANY, IN 47150
 PHONE: 812-944-6733 FAX: 812-948-5047
 e-Mail: info@SAMTEC.com code 55322

MATERIAL: DO NOT SCALE DRAWING
 INSULATOR: LCP, COLOR: BLACK
 CLIP: COPPER ALLOY
 PCB: FR4, COPPER

SHEET SCALE: 2:1

DESCRIPTION: SEAR RISER ASSEMBLY
 DWG. NO. SEAR-XX-XX.X-XX-XXXX
 BY: R MUSSER 05/06/2010 SHEET 1 OF 8

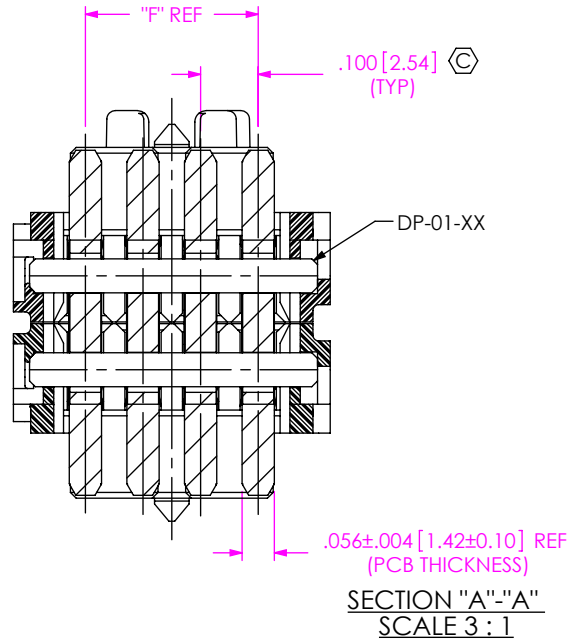
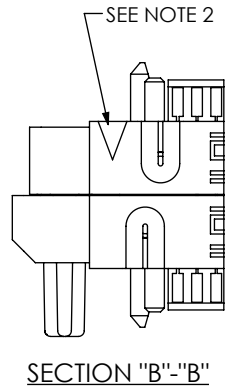

STYLE	"D"
-10.0	.383 [9.73]
-20.0	.777 [19.73]
-30.0	1.170 [29.73]
***-31.0	1.210 [30.73]

(***= TOOLED ONLY FOR -085Q OHM OPTION)

No. OF ROWS	"E"	"F"	DP-01-XX
*-04	.350 [8.89]	.100 [2.54]	DP-01-04
-06	.450 [11.43]	.200 [5.08]	DP-01-06
-08	.550 [13.97]	.300 [7.62]	DP-01-08
-10	.650 [16.51]	.400 [10.16]	DP-01-10

(* = NOT TOOLED)

No. OF POS	"A"	"B"	"C"
*-10	1.312 [33.32]	1.222 [31.04]	.696 [17.68]
*-15	1.562 [39.67]	1.472 [37.39]	.946 [24.03]
***-20	1.812 [46.02]	1.722 [43.74]	1.196 [30.38]
*-30	2.312 [58.72]	2.222 [56.44]	1.696 [43.08]
-40	2.812 [71.42]	2.722 [69.14]	2.196 [55.78]
-50	3.312 [84.12]	3.222 [81.84]	2.696 [68.48]

(* = NOT TOOLED; *** = TOOLED ONLY FOR 085 & 085Q OPTION)

SEAR ASSEMBLY (OHMS)	PCB P/N	ALTERNATE BOM PCB's
SEAR-XX-XX.X-XX-050	S-SEAR-PCB-XX-XX.X-1	PCB-102598-SEAR-XX-XX.X
SEAR-XX-XX.X-XX-085	S-SEAR-PCB-XX-XX.X-2	PCB-102596-SEAR-XX-XX.X
SEAR-20-31.0-10-085Q	S-SEAR-PCB-20-31.0-3	PCB-105033-SEAR-20-31.0
SEAR-40-31.0-XX-085Q	S-SEAR-PCB-40-31.0-3	PCB-105033-SEAR-40-31.0
SEAR-XX-XX.X-XX-100	S-SEAR-PCB-XX-XX.X-4	PCB-108868-SEAR-XX-XX.X

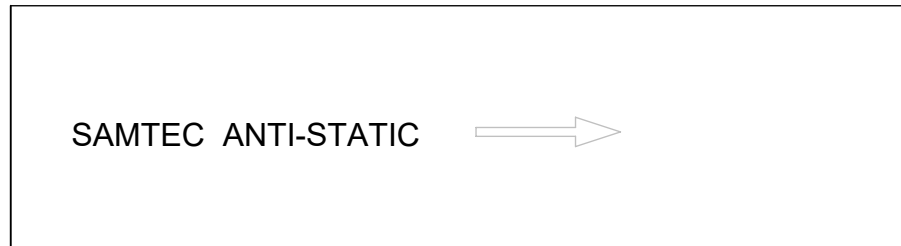

SEE TABLE 7

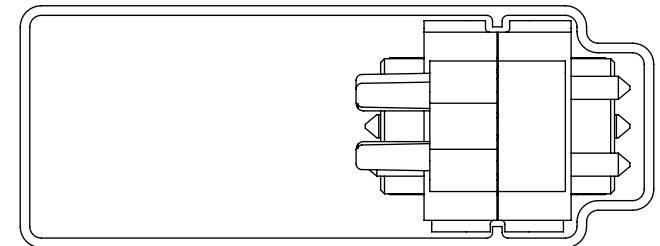

FIG 2
SEAR-40-10.0-08 SHOWN
(SHOWN IN PACKAGING TUBE)

SEAR ASSEMBLY (ROW)	PACKAGING TUBE P/N	TUBE PLUG P/N (2 REQ'D)
SEAR-XX-XX.X-06	PT-SEAR001-06	TP-31
SEAR-XX-XX.X-08	PT-SEAR002-08	TP-31
SEAR-XX-XX.X-10	PT-SEAR003-10	TP-31

PROPRIETARY NOTE
 THIS DOCUMENT CONTAINS CONFIDENTIAL AND PROPRIETARY INFORMATION AND ALL DESIGN, MANUFACTURING, REPRODUCTION, USE, PATENT RIGHTS AND SALES RIGHTS ARE EXPRESSLY RESERVED BY SAMTEC, INC. THIS DOCUMENT SHALL NOT BE DISCLOSED, IN WHOLE OR PART, TO ANY UNAUTHORIZED PERSON OR ENTITY NOR REPRODUCED, TRANSFERRED OR INCORPORATED IN ANY OTHER PROJECT IN ANY MANNER WITHOUT THE EXPRESS WRITTEN CONSENT OF SAMTEC, INC.

DO NOT SCALE DRAWING

SHEET SCALE: 2:1

520 PARK EAST BLVD, NEW ALBANY, IN 47150
 PHONE: 812-944-6733 FAX: 812-948-5047
 e-Mail info@SAMTEC.com code 55322

DESCRIPTION: SEAR RISER ASSEMBLY

DWG. NO. SEAR-XX-XX.X-XX-XXXX

BY: R MUSSER 05/06/2010 SHEET 2 OF 8

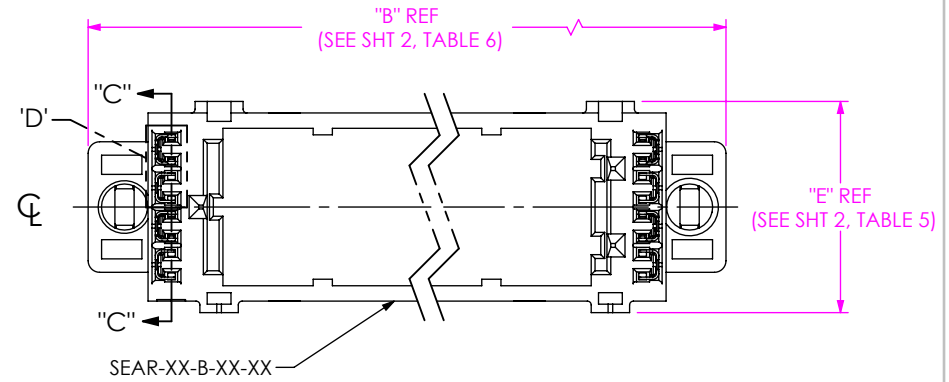
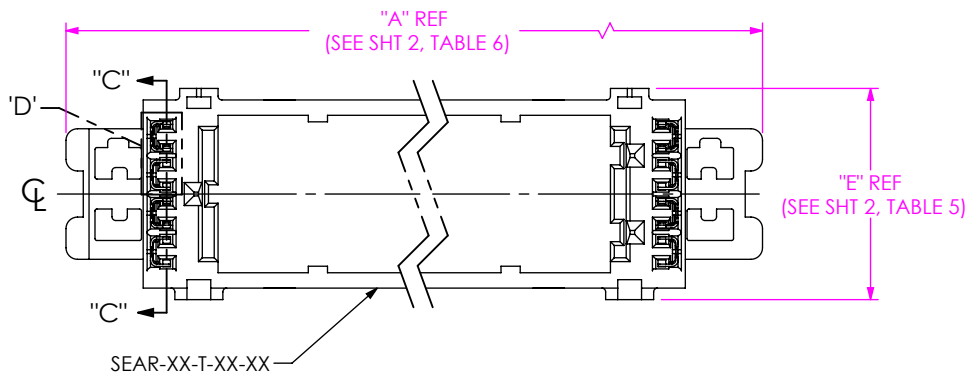

IN PROCESS 1
(INSERT PCB CENTERING CLIPS INTO BODIES)
(SEE NOTE 3)

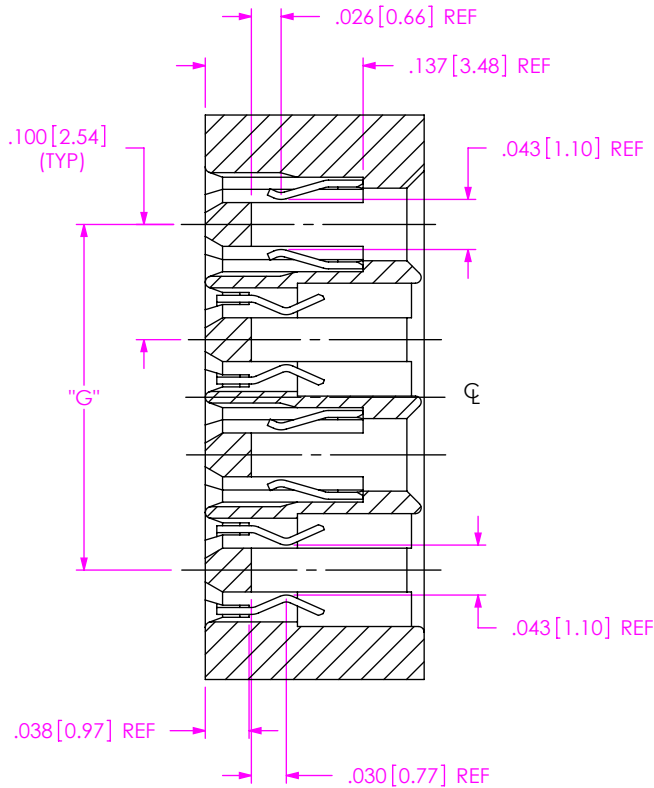

SECTION "C"-"C"
SCALE 6 : 1

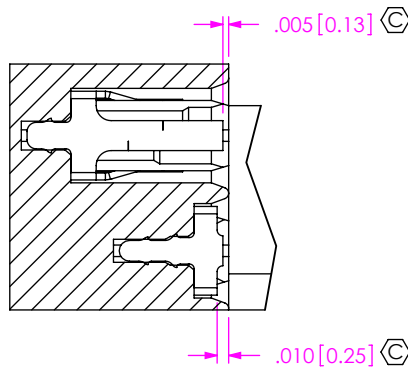

SECTION "E"-"E"
SCALE 6 : 1

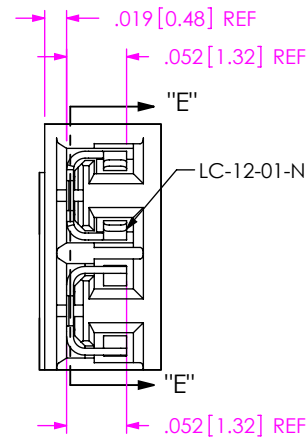

DETAIL 'D'
SCALE 6 : 1

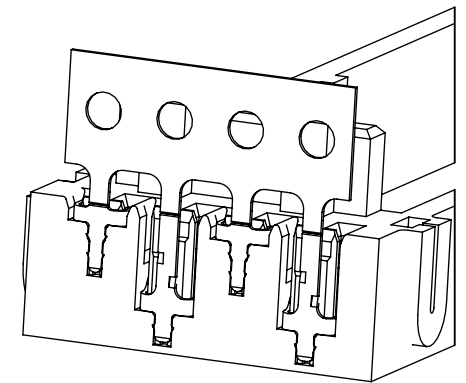

No. OF ROWS	"G"
*-04	.100 [2.54]
-06	.200 [5.08]
-08	.300 [7.62]
-10	.400 [10.16]

(* = NOT TOOLED)

PROPRIETARY NOTE
THIS DOCUMENT CONTAINS CONFIDENTIAL AND PROPRIETARY INFORMATION AND ALL DESIGN, MANUFACTURING, REPRODUCTION, USE, PATENT RIGHTS AND SALES RIGHTS ARE EXPRESSLY RESERVED BY SAMTEC, INC. THIS DOCUMENT SHALL NOT BE DISCLOSED, IN WHOLE OR PART, TO ANY UNAUTHORIZED PERSON OR ENTITY NOR REPRODUCED, TRANSFERRED OR INCORPORATED IN ANY OTHER PROJECT IN ANY MANNER WITHOUT THE EXPRESS WRITTEN CONSENT OF SAMTEC, INC.

DO NOT SCALE DRAWING

SHEET SCALE: 2:1



520 PARK EAST BLVD, NEW ALBANY, IN 47150
PHONE: 812-944-6733 FAX: 812-948-5047
e-Mail info@SAMTEC.com code 55322

DESCRIPTION: SEAR RISER ASSEMBLY
DWG. NO. SEAR-XX-XX.X-XX-XXXX
BY: R MUSSER 05/06/2010 SHEET 3 OF 8

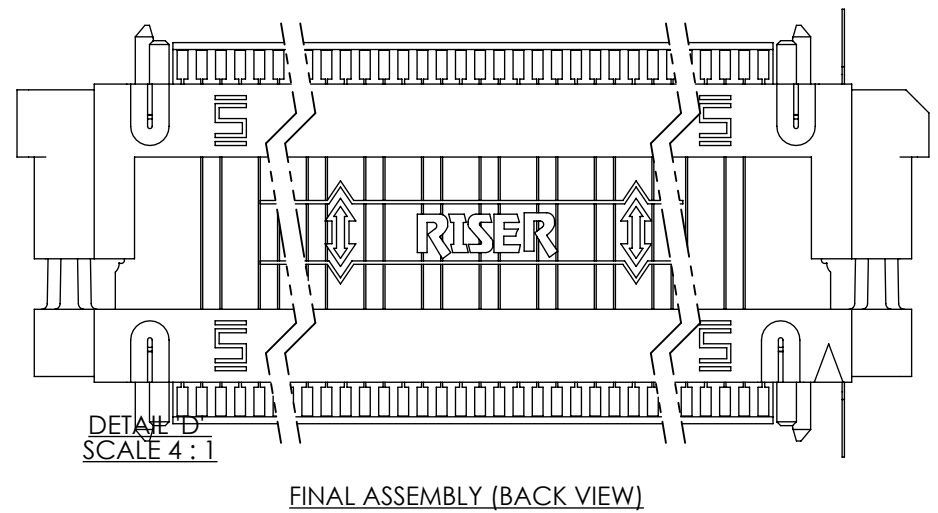
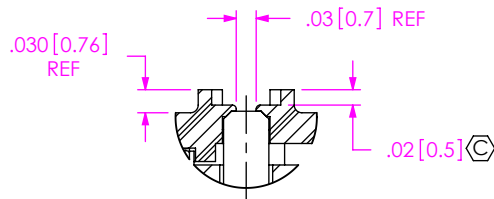
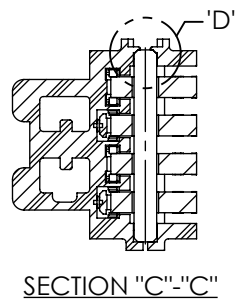
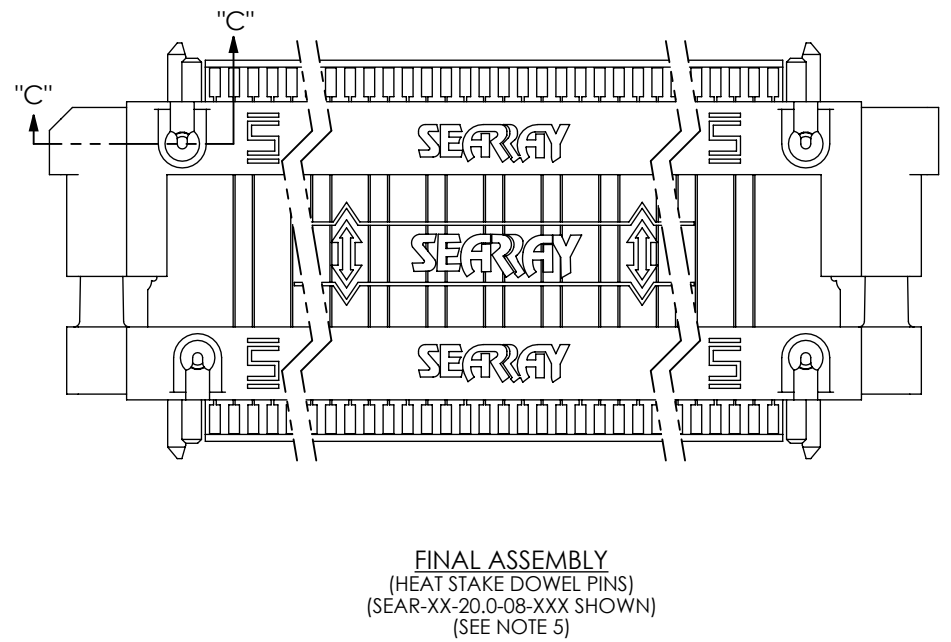
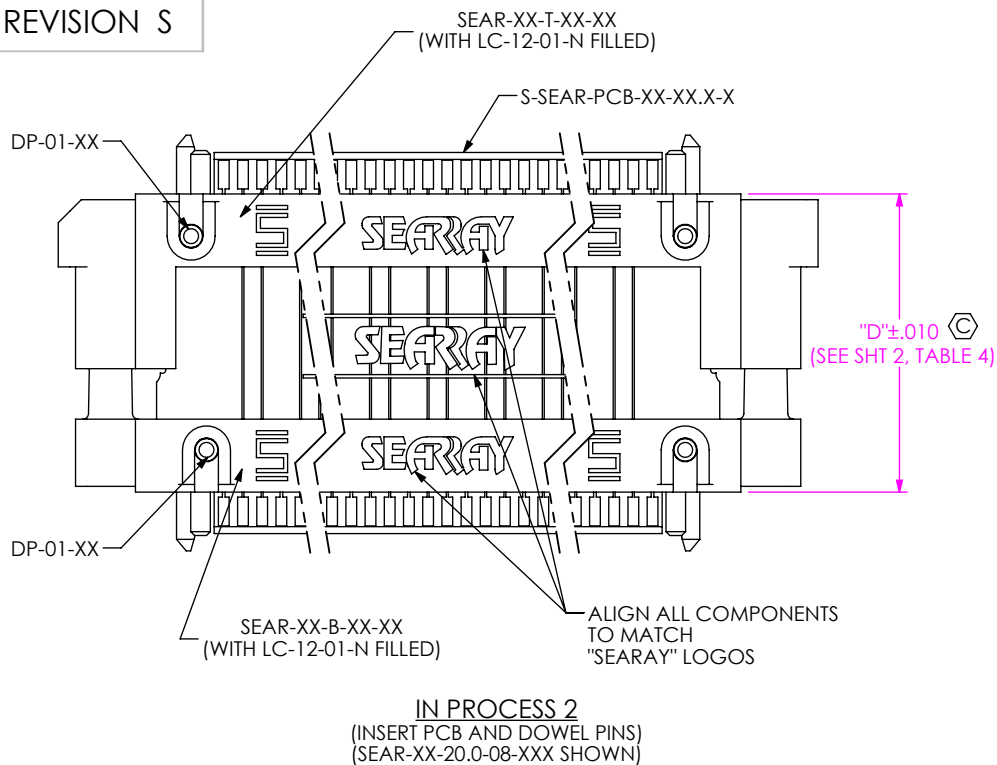

PROPRIETARY NOTE
THIS DOCUMENT CONTAINS CONFIDENTIAL AND PROPRIETARY INFORMATION AND ALL DESIGN, MANUFACTURING, REPRODUCTION, USE, PATENT RIGHTS AND SALES RIGHTS ARE EXPRESSLY RESERVED BY SAMTEC, INC. THIS DOCUMENT SHALL NOT BE DISCLOSED, IN WHOLE OR PART, TO ANY UNAUTHORIZED PERSON OR ENTITY NOR REPRODUCED, TRANSFERRED OR INCORPORATED IN ANY OTHER PROJECT IN ANY MANNER WITHOUT THE EXPRESS WRITTEN CONSENT OF SAMTEC, INC.

samtec
520 PARK EAST BLVD, NEW ALBANY, IN 47150
PHONE: 812-944-6733 FAX: 812-948-5047
e-Mail info@SAMTEC.com code 55322

DO NOT SCALE DRAWING
SHEET SCALE: 2:1

DESCRIPTION: SEAR RISER ASSEMBLY
DWG. NO. SEAR-XX-XX.X-XX-XXXX
BY: R MUSSER 05/06/2010 SHEET 4 OF 8

SEAR-40-XX.X-06-XXXX SIGNAL MAPPING FOR -085 OHMS						
Side	PCB 1		PCB 2		PCB 3	
B	A1	B1	C1	D1	E1	F1
	GND	GND	GND	GND	GND	GND
A	F1	E1	D1	C1	B1	A1
B	A2	B2	C2	D2	E2	F2
	SIG	SIG	SIG	SIG	SIG	SIG
A	F2	E2	D2	C2	B2	A2
B	A3	B3	C3	D3	E3	F3
	SIG	SIG	SIG	SIG	SIG	SIG
A	F3	E3	D3	C3	B3	A3
B
A
B	A37	B37	C37	D37	E37	F37
	GND	GND	GND	GND	GND	GND
A	F37	E37	D37	C37	B37	A37
B	A38	B38	C38	D38	E38	F38
	SIG	SIG	SIG	SIG	SIG	SIG
A	F38	E38	D38	C38	B38	A38
B	A39	B39	C39	D39	E39	F39
	SIG	SIG	SIG	SIG	SIG	SIG
A	F39	E39	D39	C39	B39	A39
B	A40	B40	C40	D40	E40	F40
	GND	GND	GND	GND	GND	GND
A	F40	E40	D40	C40	B40	A40

SEAR-40-XX.X-08-XXXX SIGNAL MAPPING FOR -085 OHMS								
Side	PCB 1		PCB 2		PCB 3		PCB 4	
B	A1	B1	C1	D1	E1	F1	G1	H1
	GND	GND	GND	GND	GND	GND	GND	GND
A	H1	G1	F1	E1	D1	C1	B1	A1
B	A2	B2	C2	D2	E2	F2	G2	H2
	SIG	SIG	SIG	SIG	SIG	SIG	SIG	SIG
A	H2	G2	F2	E2	D2	C2	B2	A2
B	A3	B3	C3	D3	E3	F3	G3	H3
	SIG	SIG	SIG	SIG	SIG	SIG	SIG	SIG
A	H3	G3	F3	E3	D3	C3	B3	A3
B
A
B	A37	B37	C37	D37	E37	F37	G37	H37
	GND	GND	GND	GND	GND	GND	GND	GND
A	H37	G37	F37	E37	D37	C37	B37	A37
B	A38	B38	C38	D38	E38	F38	G38	H38
	SIG	SIG	SIG	SIG	SIG	SIG	SIG	SIG
A	H38	G38	F38	E38	D38	C38	B38	A38
B	A39	B39	C39	D39	E39	F39	G39	H39
	SIG	SIG	SIG	SIG	SIG	SIG	SIG	SIG
A	H39	G39	F39	E39	D39	C39	B39	A39
B	A40	B40	C40	D40	E40	F40	G40	F40
	GND	GND	GND	GND	GND	GND	GND	GND
A	H40	G40	F40	E40	D40	C40	B40	A40

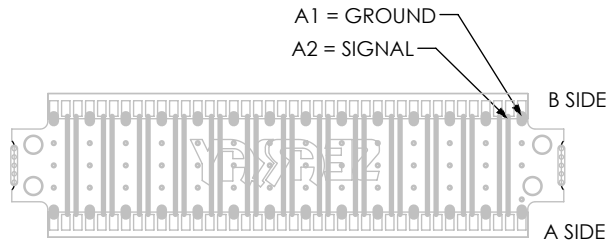

PCB 1 SHOWN

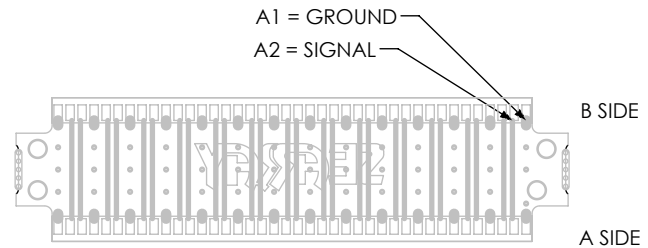

PCB 1 SHOWN

PROPRIETARY NOTE
 THIS DOCUMENT CONTAINS CONFIDENTIAL AND PROPRIETARY INFORMATION AND ALL DESIGN, MANUFACTURING, REPRODUCTION, USE, PATENT RIGHTS AND SALES RIGHTS ARE EXPRESSLY RESERVED BY SAMTEC, INC. THIS DOCUMENT SHALL NOT BE DISCLOSED, IN WHOLE OR PART, TO ANY UNAUTHORIZED PERSON OR ENTITY NOR REPRODUCED, TRANSFERRED OR INCORPORATED IN ANY OTHER PROJECT IN ANY MANNER WITHOUT THE EXPRESS WRITTEN CONSENT OF SAMTEC, INC.

DO NOT SCALE DRAWING

SHEET SCALE: 2:1



520 PARK EAST BLVD, NEW ALBANY, IN 47150
 PHONE: 812-944-6733 FAX: 812-948-5047
 e-Mail info@SAMTEC.com code 55322

DESCRIPTION: SEAR RISER ASSEMBLY
 DWG. NO. SEAR-XX-XX.X-XX-XXXX
 BY: R MUSSEY 05/06/2010 SHEET 5 OF 8

SEAR-40-XX.X-10-XXXX SIGNAL MAPPING FOR -085 & -100 OHMS										
Side	PCB 1	PCB 2	PCB 3	PCB 4	PCB 5	PCB 6	PCB 7	PCB 8	PCB 9	PCB 10
B	A1	B1	C1	D1	E1	F1	G1	H1	I1	J1
	GND	GND	GND	GND	GND	GND	GND	GND	GND	GND
A	J1	I1	H1	G1	F1	E1	D1	C1	B1	A1
B	A2	B2	C2	D2	E2	F2	G2	H2	I2	J2
	SIG	SIG	SIG	SIG	SIG	SIG	SIG	SIG	SIG	SIG
A	J2'	I2	H2	G2	F2	E2	D2	C2	B2	A2
B	A3	B3	C3	D3	E3	F3	G3	H3	I3	J3
	SIG	SIG	SIG	SIG	SIG	SIG	SIG	SIG	SIG	SIG
A	J3	I3	H3	G3	F3	E3	D3	C3	B3	A3
B
A
B	A37	B37	C37	D37	E37	F38	G37	H37	I37	J37
	GND	GND	GND	GND	GND	GND	GND	GND	GND	GND
A	J37	I37	H37	G37	F37	E37	D37	C37	B37	A37
B	A38	B38	C38	D38	E38	F38	G38	H38	I38	J38
	SIG	SIG	SIG	SIG	SIG	SIG	SIG	SIG	SIG	SIG
A	J38	I38	H38	G38	F38	E38	D38	C38	B38	A38
B	A39	B39	C39	D39	E39	F39	G39	H39	I39	J39
	SIG	SIG	SIG	SIG	SIG	SIG	SIG	SIG	SIG	SIG
A	J39	I39	H39	G39	F39	E39	D39	C39	B39	A39
B	A40	B40	C40	D40	E40	F40	G40	H40	I40	J40
	GND	GND	GND	GND	GND	GND	GND	GND	GND	GND
A	J40	I40	H40	G40	F40	E40	D40	C40	B40	A40

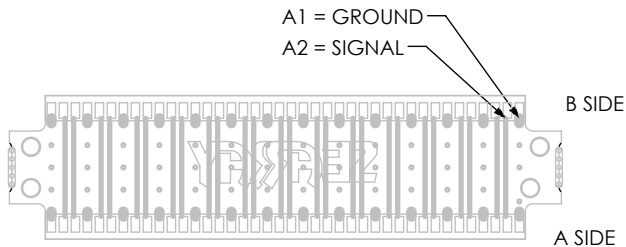

PCB 1 SHOWN

SEAR-50-XX.X-06-XXXX SIGNAL MAPPING FOR -085 OHMS						
Side	PCB 1	PCB 2	PCB 3	PCB 4	PCB 5	PCB 6
B	A1	B1	C1	D1	E1	F1
	GND	GND	GND	GND	GND	GND
A	F1	E1	D1	C1	B1	A1
B	A2	B2	C2	D2	E2	F2
	SIG	SIG	SIG	SIG	SIG	SIG
A	F2	E2	D2	C2	B2	A2
B	A3	B3	C3	D3	E3	F3
	SIG	SIG	SIG	SIG	SIG	SIG
A	F3	E3	D3	C3	B3	A3
B	A4	B4	C4	D4	E4	F4
	GND	GND	GND	GND	GND	GND
A	F4	E4	D4	C4	B4	A4
B
A
B	A47	B47	C47	D47	E47	F47
	GND	GND	GND	GND	GND	GND
A	F47	E47	D47	C47	B47	A47
B	A48	B48	C48	D48	E48	F48
	SIG	SIG	SIG	SIG	SIG	SIG
A	F48	E48	D48	C48	B48	A48
B	A49	B49	C49	D49	E49	F49
	GND	GND	GND	GND	GND	GND
A	F49	E49	D49	C49	B49	A49
B	A50	B50	C50	D50	E50	F50
	GND	GND	GND	GND	GND	GND
A	F50	E50	D50	C50	B50	A50

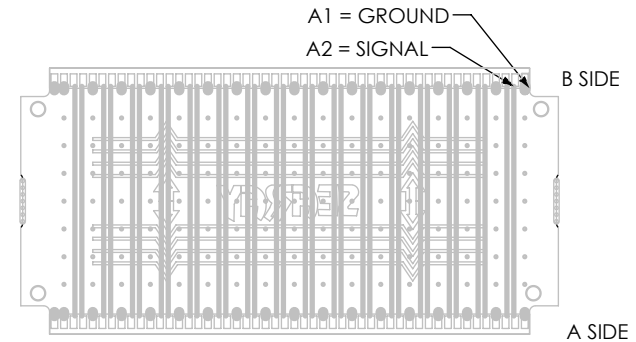

PCB 1 SHOWN

PROPRIETARY NOTE
 THIS DOCUMENT CONTAINS CONFIDENTIAL AND PROPRIETARY INFORMATION AND ALL DESIGN, MANUFACTURING, REPRODUCTION, USE, PATENT RIGHTS AND SALES RIGHTS ARE EXPRESSLY RESERVED BY SAMTEC, INC. THIS DOCUMENT SHALL NOT BE DISCLOSED, IN WHOLE OR PART, TO ANY UNAUTHORIZED PERSON OR ENTITY NOR REPRODUCED, TRANSFERRED OR INCORPORATED IN ANY OTHER PROJECT IN ANY MANNER WITHOUT THE EXPRESS WRITTEN CONSENT OF SAMTEC, INC.

DO NOT SCALE DRAWING

SHEET SCALE: 2:1



520 PARK EAST BLVD, NEW ALBANY, IN 47150
 PHONE: 812-944-6733 FAX: 812-948-5047
 e-Mail info@SAMTEC.com code 55322

DESCRIPTION: SEAR RISER ASSEMBLY
 DWG. NO. SEAR-XX-XX.X-XX-XXXX
 BY: R MUSSER 05/06/2010 SHEET 6 OF 8

SEAR-50-XX.X-08-XXXX SIGNAL MAPPING FOR -085 OHMS									
Side	PCB 1		PCB 2		PCB 3		PCB 4		
B	A1	B1	C1	D1	E1	F1	G1	H1	
	GND	GND	GND	GND	GND	GND	GND	GND	
A	H1	G1	F1	E1	D1	C1	B1	A1	
B	A2	B2	C2	D2	E2	F2	G2	H2	
	SIG	SIG	SIG	SIG	SIG	SIG	SIG	SIG	
A	H2	A2	F2	E2	D2	C2	B2	A2	
B	A3	B3	C3	D3	E3	F3	A3	H3	
	SIG	SIG	SIG	SIG	SIG	SIG	SIG	SIG	
A	H3	G3	F3	E3	D3	C3	B3	A3	
B	
A	
B	A46	B46	C46	D46	E46	F46	G46	H46	
	GND	GND	GND	GND	GND	GND	GND	GND	
A	H46	G46	F46	E46	D46	C46	B46	A46	
B	A47	B47	C47	D47	E47	F47	G47	H47	
	SIG	SIG	SIG	SIG	SIG	SIG	SIG	SIG	
A	H47	G47	F47	E47	D47	C47	B47	A47	
B	A48	B48	C48	D48	E48	F48	G48	H48	
	SIG	SIG	SIG	SIG	SIG	SIG	SIG	SIG	
A	H48	G48	F48	E48	D48	C48	B48	A48	
B	A49	B49	C49	D49	E49	F49	G49	H49	
	GND	GND	GND	GND	GND	GND	GND	GND	
A	H49	G49	F49	E49	D49	C49	B49	A49	
B	A50	B50	C50	D50	E50	F50	G50	H50	
	GND	GND	GND	GND	GND	GND	GND	GND	
A	H50	G50	F50	E50	D50	C50	B50	A50	

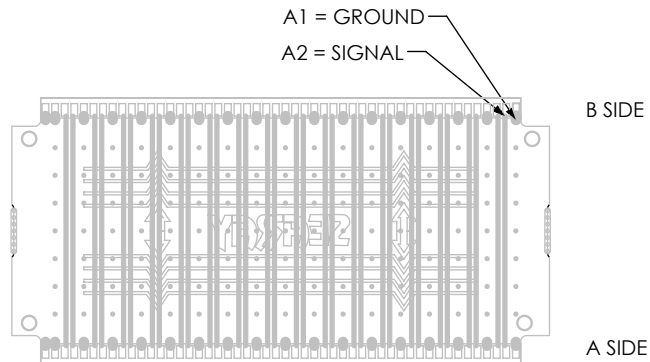

PCB 1 SHOWN

SEAR-50-XX.X-10-XXXX SIGNAL MAPPING FOR -085 OHMS										
Side	PCB 1		PCB 2		PCB 3		PCB 4		PCB 5	
B	A1	B1	C1	D1	E1	F1	G1	H1	I1	J1
	GND	GND	GND	GND	GND	GND	GND	GND	GND	GND
A	J1	I1	H1	G1	F1	E1	D1	C1	B1	A1
B	A2	B2	C2	D2	E2	F2	G2	H2	I2	J2
	SIG	SIG	SIG	SIG	SIG	SIG	SIG	SIG	SIG	SIG
A	J2	I2	H2	G2	F2	E2	D2	C2	B2	A2
B	A3	B3	C3	D3	E3	F3	G3	H3	I3	J3
	SIG	SIG	SIG	SIG	SIG	SIG	SIG	SIG	SIG	SIG
A	J3	I3	H3	G3	F3	E3	D3	C3	B3	A3
B
A
B	A46	B46	C46	D46	E46	F46	G46	H46	I46	J46
	GND	GND	GND	GND	GND	GND	GND	GND	GND	GND
A	J46	I46	H46	G46	F46	E46	D46	C46	B46	A46
B	A47	B47	C47	D47	E47	F47	G47	H47	I47	J47
	SIG	SIG	SIG	SIG	SIG	SIG	SIG	SIG	SIG	SIG
A	J47	I47	H47	G47	F47	E47	D47	C47	B47	A47
B	A48	B48	C48	D48	E48	F48	G48	H48	I48	J48
	SIG	SIG	SIG	SIG	SIG	SIG	SIG	SIG	SIG	SIG
A	J48	I48	H48	G48	F48	E48	D48	C48	B48	A48
B	A49	B49	C49	D49	E49	F49	G49	H49	I49	J49
	GND	GND	GND	GND	GND	GND	GND	GND	GND	GND
A	J49	I49	H49	G49	F49	E49	D49	C49	B49	A49
B	A50	B50	C50	D50	E50	F50	G50	H50	I50	J50
	GND	GND	GND	GND	GND	GND	GND	GND	GND	GND
A	J50	I50	H50	G50	F50	E50	D50	C50	B50	A50

PCB 1 SHOWN

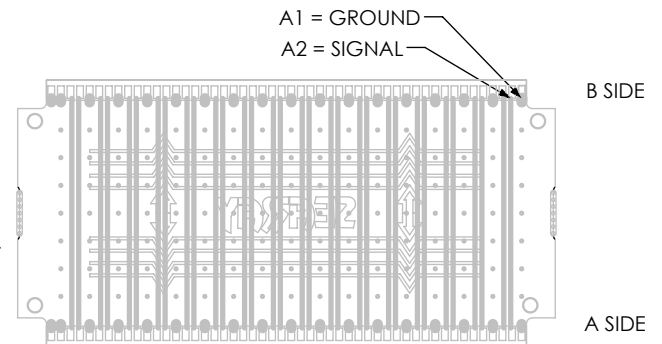

PROPRIETARY NOTE
THIS DOCUMENT CONTAINS CONFIDENTIAL AND PROPRIETARY INFORMATION AND ALL DESIGN, MANUFACTURING, REPRODUCTION, USE, PATENT RIGHTS AND SALES RIGHTS ARE EXPRESSLY RESERVED BY SAMTEC, INC. THIS DOCUMENT SHALL NOT BE DISCLOSED, IN WHOLE OR PART, TO ANY UNAUTHORIZED PERSON OR ENTITY NOR REPRODUCED, TRANSFERRED OR INCORPORATED IN ANY OTHER PROJECT IN ANY MANNER WITHOUT THE EXPRESS WRITTEN CONSENT OF SAMTEC, INC.

DO NOT SCALE DRAWING

SHEET SCALE: 2:1



520 PARK EAST BLVD, NEW ALBANY, IN 47150
PHONE: 812-944-6733 FAX: 812-948-5047
e-Mail info@SAMTEC.com code 55322

DESCRIPTION: SEAR RISER ASSEMBLY
DWG. NO. SEAR-XX-XX.X-XX-XXXX
BY: R MUSSER 05/06/2010 SHEET 7 OF 8

SEAR-40-XX.X-10-XXXX SIGNAL MAPPING FOR -085Q										
Side	PCB 1		PCB 2		PCB 3		PCB 4		PCB 5	
B	A1	B1	C1	D1	E1	F1	G1	H1	I1	J1
	GND	SIG	GND	SIG	GND	SIG	GND	SIG	GND	SIG
A	J1	I1	H1	G1	F1	E1	D1	C1	B1	A1
B	A2	B2	C2	D2	E2	F2	G2	H2	I2	J2
	GND	SIG	GND	SIG	GND	SIG	GND	SIG	GND	SIG
A	J2	I2	H2	G2	F2	E2	D2	C2	B2	A2
B	A3	B3	C3	D3	E3	F3	G3	H3	I3	J3
	SIG	GND	SIG	GND	SIG	GND	SIG	GND	SIG	GND
A	J3	I3	H3	G3	F3	E3	D3	C3	B3	A3
B	A4	B4	C4	D4	E3	F3	G3	H3	I3	J3
	SIG	GND	SIG	GND	SIG	GND	SIG	GND	SIG	GND
A	J4	I3	H3	G3	F3	E3	D3	C3	B3	A3
B	A5	B2	C2	D2	E2	F2	G2	H2	I2	J2
	GND	SIG	GND	SIG	GND	SIG	GND	SIG	GND	SIG
A	J5	I2	H2	G2	F2	E2	D2	C2	B2	A2
B
A
B	A39	B39	C39	D39	E39	F39	G39	H39	I39	J39
	SIG	GND	SIG	GND	SIG	GND	SIG	GND	SIG	GND
A	J39	I39	H39	G39	F39	E39	D39	C39	B39	A39
B	A40	B40	C40	D40	E40	F40	G40	H40	I40	J40
	SIG	GND	SIG	GND	SIG	GND	SIG	GND	SIG	GND
A	J40	I40	H40	G40	F40	E40	D40	C40	B40	A40

SEAR-20-XX.X-10-XXXX SIGNAL MAPPING FOR -085Q										
Side	PCB 1		PCB 2		PCB 3		PCB 4		PCB 5	
B	A1	B1	C1	D1	E1	F1	G1	H1	I1	J1
	GND	SIG	GND	SIG	GND	SIG	GND	SIG	GND	SIG
A	J1	I1	H1	G1	F1	E1	D1	C1	B1	A1
B	A2	B2	C2	D2	E2	F2	G2	H2	I2	J2
	GND	SIG	GND	SIG	GND	SIG	GND	SIG	GND	SIG
A	J2	I2	H2	G2	F2	E2	D2	C2	B2	A2
B	A3	B3	C3	D3	E3	F3	G3	H3	I3	J3
	SIG	GND	SIG	GND	SIG	GND	SIG	GND	SIG	GND
A	J3	I3	H3	G3	F3	E3	D3	C3	B3	A3
B	A4	B4	C4	D4	E3	F3	G3	H3	I3	J3
	SIG	GND	SIG	GND	SIG	GND	SIG	GND	SIG	GND
A	J4	I3	H3	G3	F3	E3	D3	C3	B3	A3
B	A5	B2	C2	D2	E2	F2	G2	H2	I2	J2
	GND	SIG	GND	SIG	GND	SIG	GND	SIG	GND	SIG
A	J5	I2	H2	G2	F2	E2	D2	C2	B2	A2
B
A
B	A19	B19	C19	D19	E19	F19	G19	H19	I19	J19
	SIG	GND	SIG	GND	SIG	GND	SIG	GND	SIG	GND
A	J19	I19	H19	G19	F19	E19	D19	C19	B19	A19
B	A20	B20	C20	D20	E20	F20	G20	H20	I20	J20
	SIG	GND	SIG	GND	SIG	GND	SIG	GND	SIG	GND
A	J20	I20	H20	G20	F20	E20	D20	C20	B20	A20

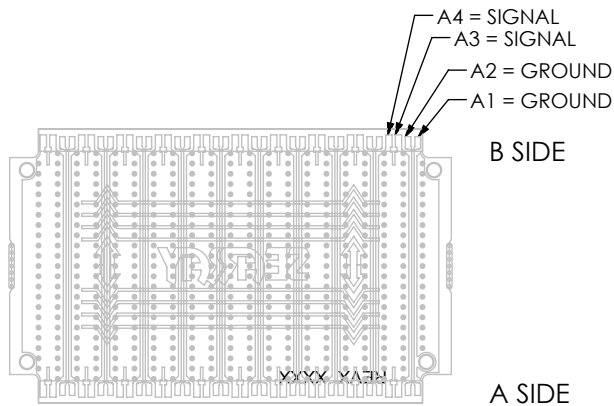

PCB 1 SHOWN

PCB 1 SHOWN

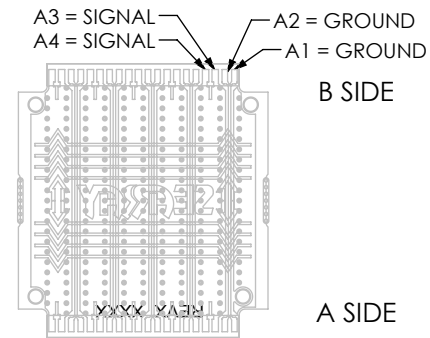

<p>PROPRIETARY NOTE</p> <p>THIS DOCUMENT CONTAINS CONFIDENTIAL AND PROPRIETARY INFORMATION AND ALL DESIGN, MANUFACTURING, REPRODUCTION, USE, PATENT RIGHTS AND SALES RIGHTS ARE EXPRESSLY RESERVED BY SAMTEC, INC. THIS DOCUMENT SHALL NOT BE DISCLOSED, IN WHOLE OR PART, TO ANY UNAUTHORIZED PERSON OR ENTITY NOR REPRODUCED, TRANSFERRED OR INCORPORATED IN ANY OTHER PROJECT IN ANY MANNER WITHOUT THE EXPRESS WRITTEN CONSENT OF SAMTEC, INC.</p>	<p>DESCRIPTION: SEAR RISER ASSEMBLY</p>	
	<p>DWG. NO. SEAR-XX-XX.X-XX-XXXX</p>	
	<p>BY: R MUSSER 05/06/2010 SHEET 8 OF 8</p>	

SHEET SCALE: 2:1

520 PARK EAST BLVD., NEW ALBANY, IN 47150
PHONE: 812-944-6733 FAX: 812-948-5047
e-Mail: info@SAMTEC.com code 55322