

DO NOT SCALE FROM THIS PRINT

TABLE 1		
SUFFIX	TAIL LENGTH "A"	TAIL WIDTH "B"
-X1	.120 [3.05]	.020 [0.51]
-X3	.075 [1.91]	.016 [0.41]

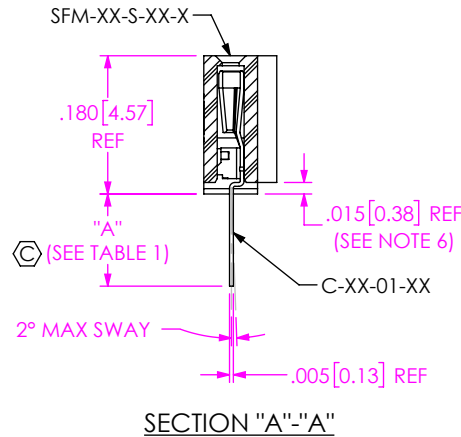
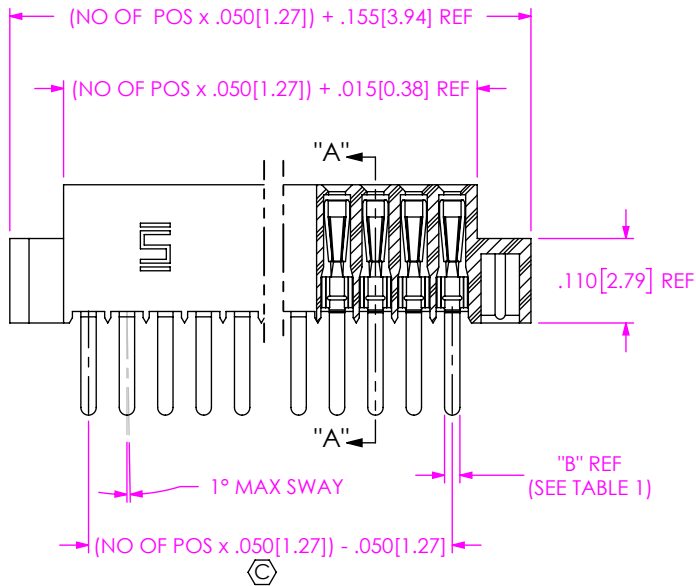
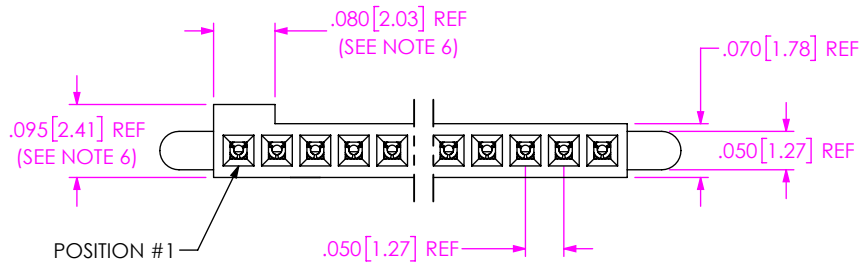

FIG 1  
THROUGH HOLE/STRAIGHT MODIFIED  
(SFM-130-X1-XX-S SHOWN)

SFM-1XX-XX-XX-S-XX-X-XX

No OF POSITIONS  
ALL POSITIONS AVAILABLE  
-02 THRU -50  
USE BODY (SFM-XX-S-XX-X)

- LEAD STYLE**
- 01: THROUGH HOLE  
USE CONTACT: (C-44-01-XX)  
(SEE FIG 1)
  - 02: SURFACE MOUNT  
USE CONTACT: (C-44-02-XX)  
(SEE FIG 2)
  - 03: STRAIGHT MODIFIED  
USE CONTACT: (C-44-03-XX)  
(SEE FIG 1)
  - L1: THROUGH HOLE (LOW INSERTION)  
USE CONTACT: (C-61-01-XXX)  
(SEE FIG 1)
  - L2: SURFACE MOUNT (LOW INSERTION)  
USE CONTACT: (C-61-02-XXX)  
(SEE FIG 2)
  - L3: STRAIGHT MODIFIED (LOW INSERTION)  
USE CONTACT: (C-61-03-XX)  
(SEE FIG 1)
  - T1: THROUGH HOLE (PHOS BRONZE)  
USE CONTACT: (C-119-01-XXX)  
(SEE FIG 1)
  - T2: SURFACE MOUNT (PHOS BRONZE)  
USE CONTACT: (C-119-02-XXX)  
(SEE FIG 1)

**PACKAGING**  
BLANK: TUBES (SEE NOTE 4)  
-TR: TAPE & REEL (SEE NOTES 7 & 8)  
(-X2 LEAD STYLE ONLY)  
-FR: FULL REEL QTY TAPE & REEL  
(SEE NOTES 7 & 8)  
(-X2 LEAD STYLE ONLY)

**PICK & PLACE OPTION**  
-P: PICK & PLACE PAD  
(USE PPP-14, SEE FIG 4, SHT 2)  
-K: POLYAMIDE FILM  
(USE K-500-300, SEE FIG 6, SHT 2)

**OPTIONS**  
BLANK: STANDARD  
(USE SFM-XX-S-LC-X)  
-A: ALIGNMENT PIN  
(USE SFM-XX-S-A-X)  
(SEE FIG 3, SHT 2)  
-LC: LOCKING CLIP  
(USE LC-05-TM & SFM-XX-S-LC-X)  
(SEE FIG 5, SHT 2) (SEE NOTE 5)  
\*-SN: SOLDER NAIL (SEE FIG 7, SHT 3)

**BODY SPECIFICATION**  
-S: SINGLE ROW

**PLATING SPECIFICATION**  
-S: 30μ" SELECTIVE GOLD IN CONTACT AREA,  
MATTE TIN ON TAIL  
-F: 3μ" SELECTIVE GOLD IN CONTACT AREA,  
MATTE TIN ON TAIL  
-L: 10μ" SELECTIVE GOLD IN CONTACT AREA,  
MATTE TIN ON TAIL  
-SM: 30μ" SELECTIVE GOLD IN CONTACT AREA;  
MATTE TIN ON TAIL  
-FM: 3μ" SELECTIVE GOLD IN CONTACT AREA,  
MATTE TIN ON TAIL  
-LM: 10μ" SELECTIVE GOLD IN CONTACT AREA,  
MATTE TIN ON TAIL  
-LM: SELECTIVE LIGHT GOLD  
-SPECIFY -L IN PLATING SUFFIX -X/  
MATTE TIN TAILS  
(USE C-XX-XX-L)

\* = NOT TOOLED

NOTES:

- ⊙ REPRESENTS A CRITICAL DIMENSION FOR STATISTICAL PROCESS CONTROL.
- MINIMUM PUSHOUT FORCE: .5 LBS
- ⊙ COPLANARITY TO BE WITHIN .004[0.10]
- TUBES ARE STANDARD PACKAGING.
- DUE TO THE HIGH AMOUNT OF INSERTION FORCE NEEDED, THE -LC OPTION IS NOT COMPATIBLE WITH AUTO PLACEMENT. SAMTEC RECOMMENDS MANUAL PLACEMENT FOR ALL ASSEMBLIES WITH THE -LC OPTION.
- DIMENSION N/A FOR -N OPTION.
- ORDERS WILL BE PACKAGED ACCORDING TO THE SAMTEC PACKAGING EFFICIENCY STANDARDS (SPES) FOUND ON WWW.SAMTEC.COM.
- ATTACH LABEL TO EACH REEL.

UNLESS OTHERWISE SPECIFIED, DIMENSIONS ARE IN INCHES.  
TOLERANCES ARE:  
DECIMALS ANGLES  
.XX: ±.01 [0.3] 2°  
.XXX: ±.005 [0.13]  
.XXXX: ±.0020 [0.051]

**PROPRIETARY NOTE**  
THIS DOCUMENT CONTAINS CONFIDENTIAL AND PROPRIETARY INFORMATION AND ALL DESIGN, MANUFACTURING, REPRODUCTION, USE, PATENT RIGHTS AND SALES RIGHTS ARE EXPRESSLY RESERVED BY SAMTEC, INC. THIS DOCUMENT SHALL NOT BE DISCLOSED, IN WHOLE OR PART, TO ANY UNAUTHORIZED PERSON OR ENTITY NOR REPRODUCED, TRANSFERRED OR INCORPORATED IN ANY OTHER PROJECT IN ANY MANNER WITHOUT THE EXPRESS WRITTEN CONSENT OF SAMTEC, INC.

**MATERIAL:** DO NOT SCALE DRAWING SHEET SCALE: 4:1  
INSULATOR: VECTRA E130, COLOR: BLACK  
CONTACT: BeCu #25  
MAX FLASH ALLOWED: .002[0.05]  
MAX GATE VESTIGE: .002[0.05]

F:\DWG\MISC\MKTG\SFM-1XX-XX-XX-S-XX-X-XX-MKT.SLDRW



520 PARK EAST BLVD, NEW ALBANY, IN 47150  
PHONE: 812-944-6733 FAX: 812-948-5047  
e-Mail: info@SAMTEC.com code 55322

DESCRIPTION: .050 [1.27] C.L. SOCKET STRIP  
SINGLE ROW ASSEMBLY  
DWG. NO. SFM-1XX-XX-XX-S-XX-X-XX  
BY: REIDINGER 09/08/1992 SHEET 1 OF 3

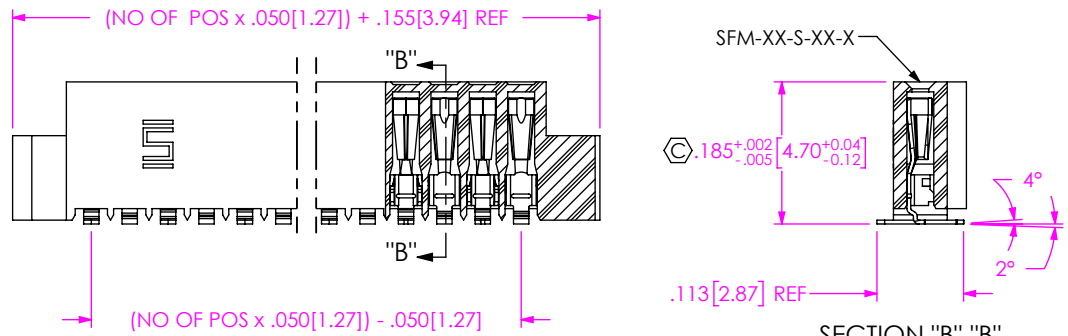
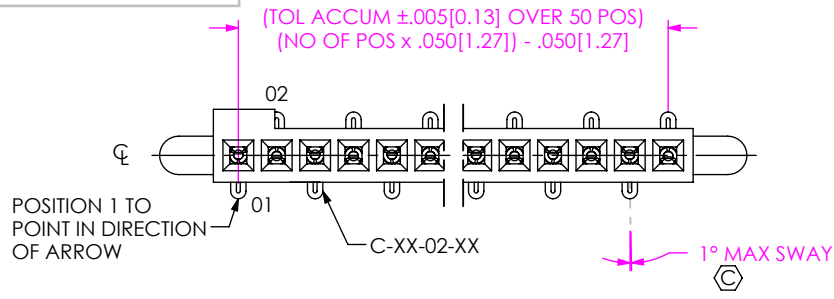

FIG 2  
SURFACE MOUNT  
DIFFERENT AS SHOWN, OTHERWISE SAME AS FIG 1  
(SFM-130-02-XX-S SHOWN)

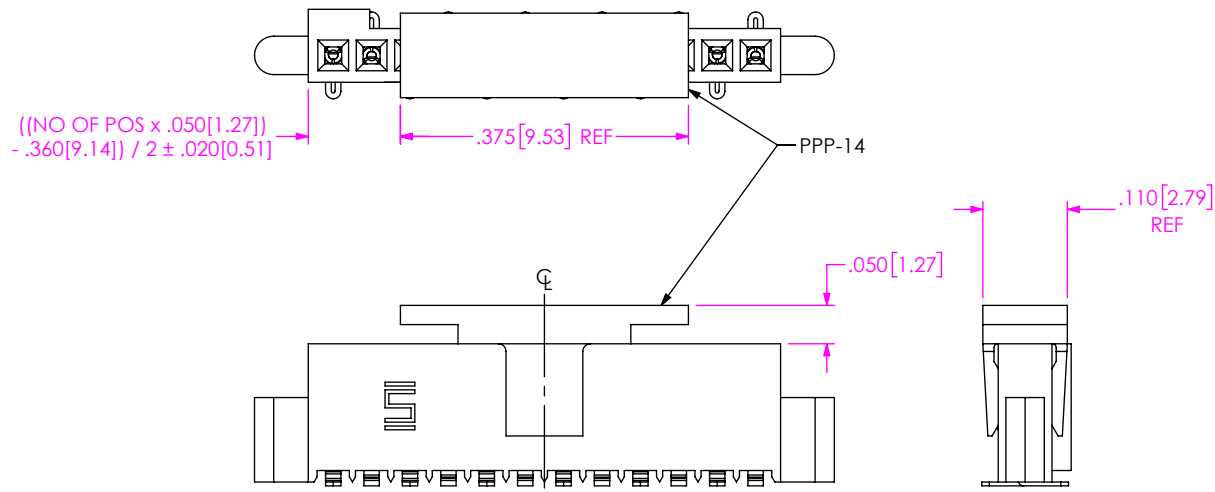

FIG 4  
-P: PICK & PLACE PAD  
DIFFERENT AS SHOWN, OTHERWISE SAME AS FIG 1  
(PLACE PAD ABOUT C.L. AS SHOWN)  
(SFM-112-02-XX-S-P SHOWN)

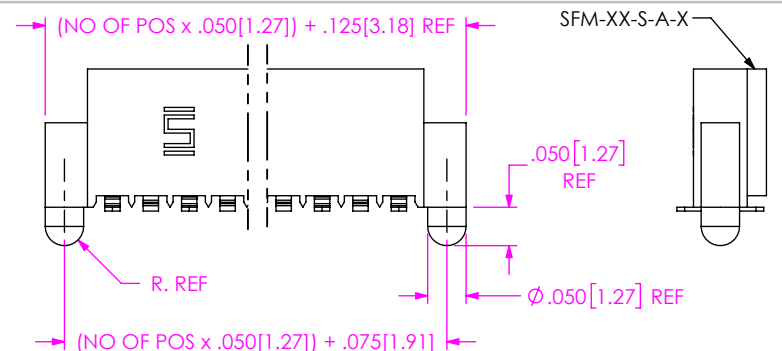

FIG 3  
-A: ALIGNMENT PIN  
DIFFERENT AS SHOWN, OTHERWISE SAME AS FIG 1  
(SFM-125-02-XX-S-A SHOWN)

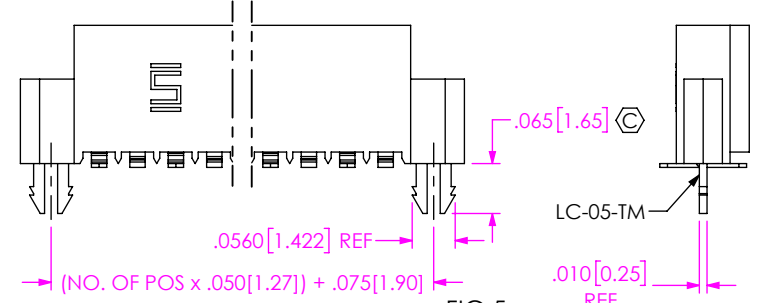

FIG 5  
-LC: LOCKING CLIP  
DIFFERENT AS SHOWN, OTHERWISE SAME AS FIG 1  
(SFM-112-02-XX-S-LC SHOWN)

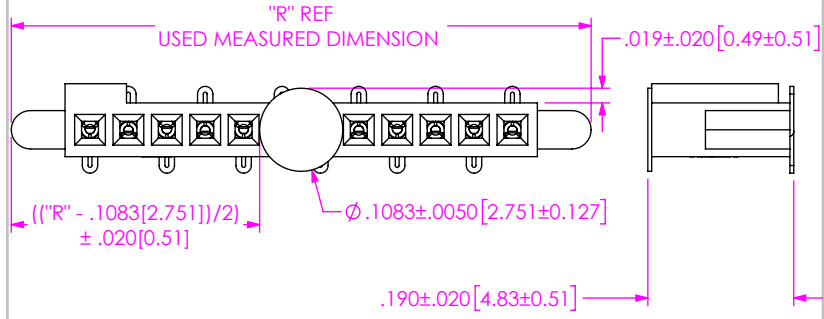

FIG 6  
-K: OPTION (POLYIMIDE FILM PAD)  
DIFFERENT AS SHOWN, OTHERWISE SAME AS FIG 1  
(SFM-112-02-XX-S-K SHOWN)

**PROPRIETARY NOTE**  
THIS DOCUMENT CONTAINS CONFIDENTIAL AND PROPRIETARY INFORMATION AND ALL DESIGN, MANUFACTURING, REPRODUCTION, USE, PATENT RIGHTS AND SALES RIGHTS ARE EXPRESSLY RESERVED BY SAMTEC, INC. THIS DOCUMENT SHALL NOT BE DISCLOSED, IN WHOLE OR PART, TO ANY UNAUTHORIZED PERSON OR ENTITY NOR REPRODUCED, TRANSFERRED OR INCORPORATED IN ANY OTHER PROJECT IN ANY MANNER WITHOUT THE EXPRESS WRITTEN CONSENT OF SAMTEC, INC.



520 PARK EAST BLVD, NEW ALBANY, IN 47150  
PHONE: 812-944-6733 FAX: 812-948-5047  
e-Mail info@SAMTEC.com code 55322

SHEET SCALE: 4:1

DESCRIPTION: .050 [1.27] C.L. SOCKET STRIP  
SINGLE ROW ASSEMBLY

DWG. NO. SFM-1XX-XX-XX-S-XX-X-XX

BY: REIDINGER 09/08/1992 SHEET 2 OF 3

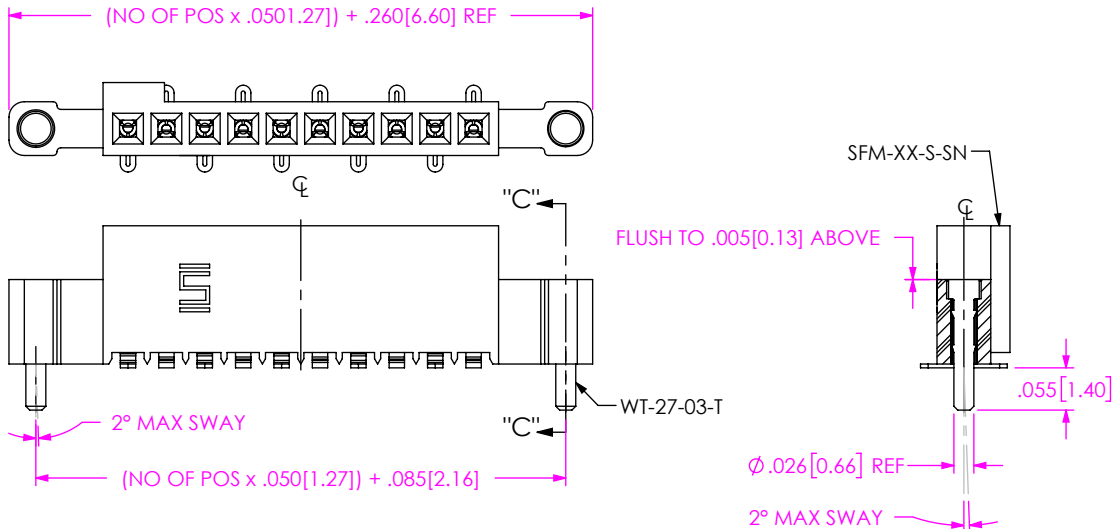
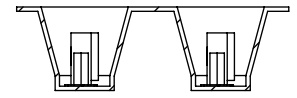
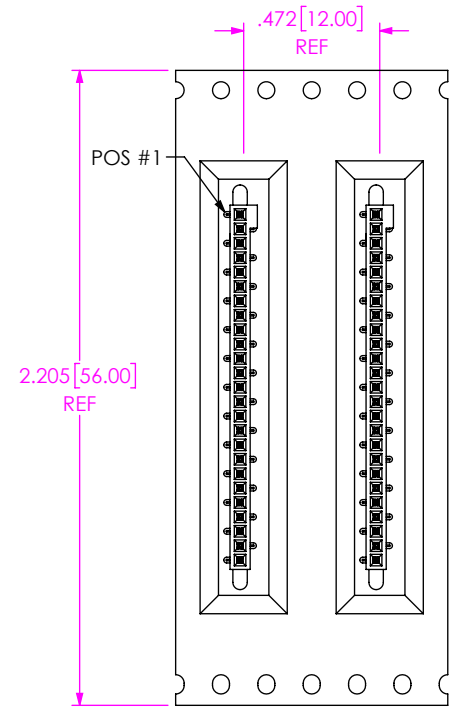
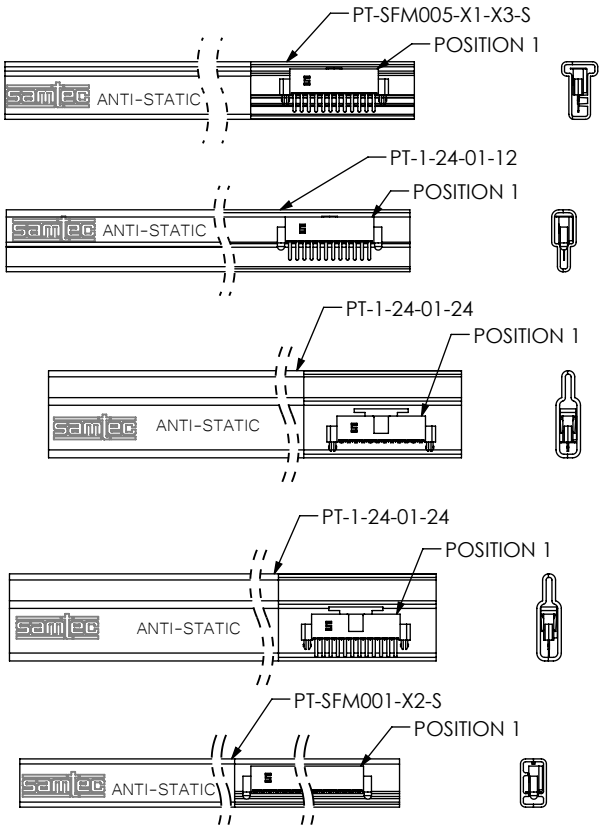

FIG 7  
 \*SN: SOLDER NAIL OPTION  
 DIFFERENT AS SHOWN, OTHERWISE SAME AS FIG 1  
 (SFM-110-02-XX-S-SN SHOWN)



TAPE & REEL VIEW  
 (SFM-125-02-XX-S-XR SHOWN)

PACKAGE PARTS IN TUBE AS SHOWN



PACKAGING TUBE TABLE

LEAD STYLE	PACKAGING TUBE	PLUG
-X1-S, -X1-S-K	PT-SFM005-X1-X3-S	TP-12
-X1-S-A, -X1-S-A-K	PT-1-24-01-12	TP-12
-X1-S-LC, -X1-S-LC-K	PT-SFM005-X1-X3-S	TP-12
-X1-S-P	PT-1-24-01-24	TP-24
-X1-S-A-P	PT-1-24-01-24	TP-24
-X1-S-LC-P	PT-1-24-01-24	TP-24
-X2-S	PT-SFM001-X2-S	TP-12
-X2-S-A	PT-SFM001-X2-S	TP-12
-X2-S-K	PT-SFM001-X2-S	TP-12
-X2-S-LC-K	PT-SFM001-X2-S	TP-12
-X3-S-SN	PT-SFM001-X2-S	TP-12
-X2-S-LC	PT-SFM001-X2-S	TP-12
-X2-S-P	PT-SFM002-X2-S	TP-12
-X2-S-A-P	PT-1-24-01-24	TP-24
-X2-S-LC-P	PT-SFM002-X2-S	TP-12
-X3-S	PT-SFM005-X1-X3-S	TP-12
-X3-S-A	PT-SFM005-X1-X3-S	TP-12
-X3-S-LC	PT-SFM005-X1-X3-S	TP-12
-X3-S-P	PT-1-24-01-24	TP-24
-X3-S-A-P	PT-1-24-01-24	TP-24
-X3-S-LC-P	PT-1-24-01-24	TP-24

**PROPRIETARY NOTE**  
 THIS DOCUMENT CONTAINS CONFIDENTIAL AND PROPRIETARY INFORMATION AND ALL DESIGN, MANUFACTURING, REPRODUCTION, USE, PATENT RIGHTS AND SALES RIGHTS ARE EXPRESSLY RESERVED BY SAMTEC, INC. THIS DOCUMENT SHALL NOT BE DISCLOSED, IN WHOLE OR PART, TO ANY UNAUTHORIZED PERSON OR ENTITY NOR REPRODUCED, TRANSFERRED OR INCORPORATED IN ANY OTHER PROJECT IN ANY MANNER WITHOUT THE EXPRESS WRITTEN CONSENT OF SAMTEC, INC.

SHEET SCALE: 4:1



520 PARK EAST BLVD., NEW ALBANY, IN 47150  
 PHONE: 812-944-6733 FAX: 812-948-5047  
 e-Mail info@SAMTEC.com code 55322

DESCRIPTION: .050 [1.27] C.L. SOCKET STRIP SINGLE ROW ASSEMBLY

DWG. NO. SFM-1XX-XX-XX-S-XX-X-XX

BY: REIDINGER 09/08/1992 SHEET 3 OF 3