

**THIS PRODUCT MANUFACTURED WITH LEAD-FREE PROCESSING**

**DESIGNED & DIMENSIONED IN MILLIMETERS [INCHES]**

**SMP-J-C-XX-RA-CS5**

GENDER  
-J: JACK

TYPE  
-C: CABLE

TERMINATION  
-CS5: MWC-2550-01 CABLE

ORIENTATION  
-RA: RIGHT ANGLE

PLATING SPECIFICATION  
-HG: HEAVY GOLD / GOLD  
30µ" Au / 50µ" Ni MIN ON PIN  
10µ" Au / 50µ" Ni MIN ON OUTER CONTACT  
3µ" Au / 50µ" Ni MIN ON CAP  
-GF: GOLD / FLASH GOLD  
10µ" Au / 50µ" Ni MIN ON PIN  
3µ" Au / 50µ" Ni MIN ON OUTER CONTACT  
100µ" Ni MIN ON CAP  
(SEE TABLE 1)

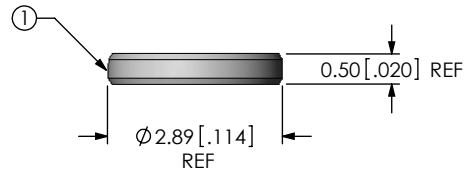
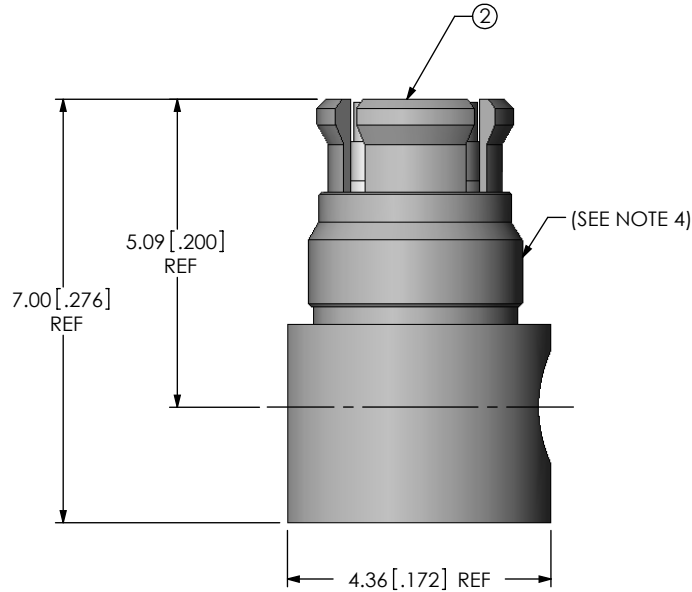

TABLE 1			
ITEM	COMPONENT	-HG	-GF
1	CAP	MMCX-CAP-001-F	MMCX-CAP-001-N
2	SUB ASSEMBLY	SUB-SMP-J-C-HG-RA-CS5	SUB-SMP-J-C-GF-RA-CS5

NOTES:

- ① REPRESENTS A CRITICAL DIMENSION.
- PRODUCT TO BE PACKAGED PER PACKING STANDARD CO-HD-WI-3040-M. TRAY: TY-SMA001-1 COVER: TY-SMA001-2 200 PARTS PER TRAY (2 PARTS PER POCKET)
- CAP TO BE PACKAGED SEPARATELY.
- THE RING IS LOOSE AND CAN MOVE. 1.5 LBS MIN FORCE TO REMOVE. **A**

UNLESS OTHERWISE SPECIFIED, DIMENSIONS ARE IN MILLIMETERS. TOLERANCES ARE:  
 DECIMALS ANGLES  
 X.X: ±0.3 [.01] 5°  
 X.XX: ±0.13 [.005]  
 X.XXX: ±0.051 [.0020]

**PROPRIETARY NOTE**  
 THIS DOCUMENT CONTAINS INFORMATION CONFIDENTIAL AND PROPRIETARY TO SAMTEC, INC. AND SHALL NOT BE REPRODUCED OR TRANSFERRED TO OTHER DOCUMENTS OR DISCLOSED TO OTHERS OR USED FOR ANY PURPOSE OTHER THAN THAT WHICH IT WAS OBTAINED WITHOUT THE EXPRESSED WRITTEN CONSENT OF SAMTEC, INC.



520 PARK EAST BLVD, NEW ALBANY, IN 47150  
 PHONE: 812-944-6733 FAX: 812-948-5047  
 e-Mail: info@SAMTEC.com code 55322

MATERIAL: DO NOT SCALE DRAWING SHEET SCALE: 8:1  
 SUB ASSEMBLY:  
 INSULATOR: PTFE  
 BODY, RING & SOCKET: BeCu  
 CAP: BRASS

DESCRIPTION:  
**SMP RA JACK FOR MWC-2550-01 - 50 OHM**

DWG. NO.  
**SMP-J-C-XX-RA-CS5**

BY: ALVIN W 07/20/2011 SHEET 1 OF 2

REVISION A

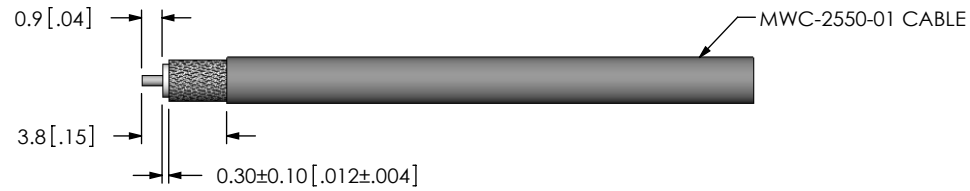

IN-PROCESS 1  
STRIP AND TIN INNER CONDUCTOR

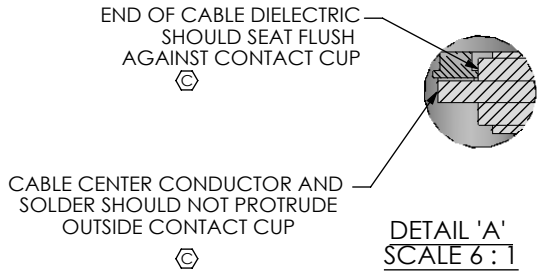

IN-PROCESS 2  
ADD SUB ASSEMBLY & SOLDER BRAID



IN-PROCESS 3  
SOLDER SIGNAL CONTACT

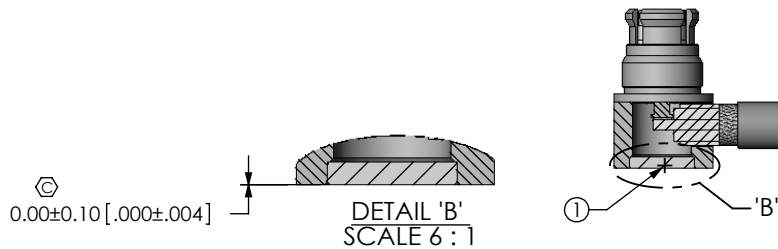

IN-PROCESS 4  
INSERT CAP

**PROPRIETARY NOTE**  
THIS DOCUMENT CONTAINS INFORMATION CONFIDENTIAL AND PROPRIETARY TO SAMTEC, INC. AND SHALL NOT BE REPRODUCED OR TRANSFERRED TO OTHER DOCUMENTS OR DISCLOSED TO OTHERS OR USED FOR ANY PURPOSE OTHER THAN THAT WHICH IT WAS OBTAINED WITHOUT THE EXPRESSED WRITTEN CONSENT OF SAMTEC, INC.

DO NOT SCALE DRAWING

SHEET SCALE: 8:1

**samtec**

520 PARK EAST BLVD, NEW ALBANY, IN 47150  
PHONE: 812-944-6733 FAX: 812-948-5047  
e-Mail: info@SAMTEC.com code 55322

DESCRIPTION:  
SMP RA JACK FOR MWC-2550-01 - 50 OHM

DWG. NO.  
**SMP-J-C-XX-RA-CS5**

BY: ALVIN W 07/20/2011 SHEET 2 OF 2